



INSTALLATION OPERATION AND MAINTENANCE INSTRUCTIONS

FAW, FAW-C & FAW-C-T TYPE AIR WARMERS

FCR & FCR-A TYPE CONVECTORS

STW & STW-T SAFE AREA AIR WARMERS

HFT, AFT & SAT TYPE AIR THERMOSTATS



**Please read these instructions thoroughly before installation and ensure they
are passed on to the end-user**

CONTENTS

1.0	GENERAL	2
2.0	STORAGE	2
3.0	PRE INSTALLATION INSPECTION AND CHECKS	3
4.0	INSTALLATION	3
5.0	ELECTRICAL SUPPLY CONNECTION	4
6.0	EARTH CONNECTION	4
7.0	OPERATION	5
8.0	MAINTENANCE	5
9.0	MARKING	6
10.0	CERTIFICATION	6
	APPENDIX A – WIRING DIAGRAMS	7
	APPENDIX B – HEATER GENERAL ARRANGEMENT DRAWINGS	18



To maintain the equipment warranty and the Hazardous Area Certification, the instructions contained within this manual must be complied with in full.

1.0 GENERAL

- 1.1 All work should be carried out by suitable qualified personnel.
- 1.2 Carefully remove all protective packaging and visually inspect unit for any transit damage.
- 1.3 Heaters must be handled with care and stored in dry conditions.
- 1.4 **CAUTION** – Air warmers over 1m long are HEAVY and must be handled appropriately.
- 32kg FAW2000
 - 38kg FAW2500
 - 42kg FAW3000
 - up to 34kg FCR2
 - up to 49kg FCR3
- 1.5 Before connection ensure that the supply corresponds with that specified on the rating label.
- 1.6 Ensure that the sizes and types of cables to be used are suitably rated for the load and temperature of the unit.
- 1.7 Each heater must be protected by a suitably rated over current device.
- 1.8 All prevailing rules, regulations and bylaws in force at the time and place of installation must be observed.
- 1.9 The heater should be securely fixed in position and all terminal connections checked for tightness before energising.
- 1.10 Any modification not carried out by Exheat Industrial Ltd will invalidate certification and warranty.
- 1.11 Refer to the relevant code of practice for the equipment:
- *IEC/EN 60079-14* for selection and installation
 - *IEC/EN 60079-17* for inspection and maintenance of electric apparatus for use in potentially explosive atmospheres.
- 1.12 All electrical testing must be carried out in a non-hazardous area.
- 1.13 Precautions must be taken to prevent damage to machined surfaces and threads of flameproof enclosures.
- 1.14 Ensure that any special conditions for safe use detailed on the Hazardous Area Certification are complied with.

2.0 STORAGE

- 2.1 Store the equipment in an inside location that is dry, clean and well ventilated.
- 2.2 Suitable preservation materials, such as silica gel bags or equivalent, have been placed inside the packaging. Additionally, spare silica gel bags, or equivalent, can be supplied by contacting Exheat Industrial Ltd.
- 2.3 If the equipment is stored beyond 3 months, ensure that preservation materials are replaced.
- 2.4 **CAUTION** – It is the client's responsibility to ensure that, if the terminal enclosure is opened prior to installation, these bags are checked and replaced if necessary. When refitting terminal enclosure lid please ensure the gaskets are not damaged or moved in any way and for the HFT & AFT thermostats please refer to section 5.0 below.
- 2.5 **CAUTION** – The following preservation instructions must be adhered to. Failure to do so could result in the equipment warranty being invalidated:
- Store the equipment at a temperature within the ambient temperature shown on the nameplate.
 - Ensure that the equipment is not subjected to direct sunlight at ambient temperatures above +30°C.

3.0 PRE INSTALLATION INSPECTION AND CHECKS

3.1 Each heater and thermostat is manufactured to the highest standard with great care and quality materials. All the goods are thoroughly inspected and tested before leaving the manufacturing plant. They must be handled with care during storage and installation. Before the installation starts it is advised that the heater is checked to ensure the insulation resistance reading is above 2MΩ per element at 500 volts dc.

3.1.1 Should the heater fail this test, isolate the power and control circuits (if installed), and follow the steps below:

- Fill the terminal box with silica gel bags, and replace the terminal box lid.
- Leave for 24hrs to draw any moisture out of the heater elements.
- If you have a heated blanket, place this over the heater elements to help with the drying. Heater blankets are available to purchase from www.exheat-industrial.com/contact/enquiry
- If the insulation resistance has not been raised to a sufficient level after 24hrs, repeat the process above with replacement gel bags.
- Should the above not raise the insulation resistance to the required level please contact the technical help on our website. www.exheat-industrial.com/contact/support

3.2 Insulation Resistance (Megger)

3.2.1 The 'Megger' should be applied between the phases and earth. A reading of greater than 2MΩ at 500 volts dc should be recorded. Should the whole heater be below this value each element would need to be checked to ascertain which one was low in resistance.

3.2.2 Use the continuity (Ohms) setting on the elements and check the resistance of each element matches or is approximately equal to the results as per the electrical test certificate that would have been sent with the heater.

4.0 INSTALLATION

4.1 Carefully remove the packaging from each item and check for damage. Immediately report any damage to Exheat Industrial Ltd.

4.2 The heater should be securely fixed in position using the pre-drilled fixing holes, and all terminal connections checked for tightness before energising.

4.3 The appliance must be securely fitted to a wall or floor using only the brackets provided.

4.3 The orientation of the heaters must be strictly adhered to with the feet facing down at all times.

4.4 The installer or end user shall ensure that the unit has free and unrestricted air flow to allow natural convection to occur at all times. **DO NOT COVER** the heater and do not allow anything to rest on or against it. This could lead to dangerous overheating and will invalidate the hazardous area certification.

4.5 At no time is the ambient temperature to be allowed to rise above +40°C (FAW & FAW-C T3 & T4 variants) Or +60°C (T2 variants). This can be achieved by the use of Exheat Industrial Ltd integral (if option available) or separate flameproof air sensing thermostats (HFT & AFT type).

4.6 The STW range may be regulated by an integral or separate industrial air sensing thermostat (SAT type)

5.0 ELECTRICAL SUPPLY CONNECTION

- 5.1 Refer to wiring diagrams in *APPENDIX A*.
- The cable entries (1 x M20) in the FAW & STW Ranges are positioned to the side of the terminal box.
 - The cable entries (1 x M20) in the FCR are positioned on the bottom of the terminal box.
 - The cable entries (2 x M20) within the HFT and AFT are pre drilled and pre tapped.
- 5.2 No additional cable entries are to be made within any of the terminal boxes. Only Exheat Industrial Ltd personnel can facilitate this.
- 5.3 The cables must enter the FAW, FAW-C, FCR and FCR-A heaters via the terminal box cable entries using Ex e cable glands and IP Washers. The cables glands installed to the HFT & AFT thermostats are to be Ex d rated. All cable glands are to be suitable for the rating and size of the supply cables. For the STW Range heaters please use cable glands suitable for the power supply.
- 5.4 Before connection ensure that the supply corresponds with that specified on the nameplate label.
- 5.5 Ensure that the sizes and types of cables to be used are suitably rated for the load and temperature of the unit.
- 5.6 Each heater must be protected by a suitably rated over current device and earth leakage circuit breaker device. See section 6 below for earthing connection details.
- 5.7 The cables must enter the heater terminal box via suitably certified cable glands and IP washers (not supplied) and be fitted by a qualified person. Any unused entries should remain plugged with the factory fitted certified Ex d plugs (if installed) or with suitably rated plugs and IP washers.
- 5.8 The covers of the HFT & AFT terminal boxes are removed after releasing the 3 (AFT) or 4 (HFT) socket head screws in the cover. When re-fitting ensure that the 'O' ring seal is in good condition and correctly located. The main cover mating and spigot faces **MUST** be kept clean and free from any debris at all times.
- 5.8.1 The covers of the STW and FCR ranges can be removed by the unscrewing of the screws.
- 5.8.2 The covers of the FAW range can be removed by unscrewing the bolts around the outside of the lids.
- 5.9 After re-fitting the lids on the HFT and AFT thermostats, the gap between the cover and the body must be checked to ensure that it does not exceed 0.15mm.
- 5.10 The installer or end user must connect to the Exheat Industrial Ltd supplied terminals within the terminal box - **DO NOT** connect to or disturb factory fitted wiring.
- 5.11 **WARNING – Silica gel bags must be removed before the heater is energised.**

6.0 EARTH CONNECTION

- 6.1 **WARNING – these heaters MUST BE EARTHED.**
- 6.2 The external earth connections for the FAW and FCR ranges are located underneath the protective guard in the same orientation as the elements. The external earth connections on the HFT & AFT ranges are on the lower corner.
- 6.3 An internal earth connection is provided inside the terminal box.

7.0 OPERATION

- 7.1 Heat is generated by means of electric heating elements. Once energized the air warmers will continue to operate until de-energized by an external (or integral) air thermostat.
- 7.2 To adjust the temperature settings on an integral thermostat (HFT), Remove the lid (as per section 5.0) and rotate the adjustable control knob clockwise to increase the desired set-point or anti-clockwise to reduce the set-point.
- 7.2.1 To adjust the temperature settings on an externally adjustable thermostat (AFT), Remove the lid (as per section 5.0) and rotate the adjuster clockwise (by use of a large flat blade screwdriver) to increase the desired set-point or anti-clockwise to reduce the set-point.
- 7.3 The FAW and FCR ranges are designed to operate in ambient temperatures of up to +40°C (T3 & T4 rated units) and +60°C (T2 rated units) and the user must ensure that this temperature is not exceeded at any time.
- 7.4 The STW air warmer range is designed to operate in ambient temperatures of up to +60°C. Where an integral adjustable thermostat is provided, this senses the ambient air temperature. Rotate the control knob clockwise to increase the set-point or anticlockwise to reduce the set-point.
- 7.5 **CAUTION** – Check that the voltage on the heater nameplate is compatible with the mains supply being used before energising the heater.

8.0 MAINTENANCE

- 8.1 All prevailing site safety regulations shall be adhered to at all times.
- 8.2 Equipment shall be checked regularly for any dust accumulation which must be removed from all surfaces.
- 8.3 Before and whilst any maintenance activity is carried out, it must be ensured that there are no hazardous gases or dusts present.
- 8.4 Equipment is to be fully isolated from the electrical supply before and whilst any work is being carried out.
- 8.5 Any damage or faults should be notified to Exheat Industrial Ltd immediately.
- 8.6 Any replacement parts required must be obtained directly from Exheat Industrial Ltd. The use of any other parts will void any certification and warranty.
- 8.7 Equipment is certified for use in a hazardous area and reference should be made to *IEC/EN 60079-14* for selection and installation.
- 8.7.1 *IEC/EN 60079-17* for inspection and maintenance of electric apparatus for use in potentially explosive atmospheres.

In addition to the following recommendations:

8.7.2 3 Monthly

- Generally inspect the equipment for external damage or leaks.
- Ensure that any spaces between the element fins, remains clear and that the airflow remains unrestricted.

8.7.3 6 Monthly

- Isolate the electrical supply and remove the cover (As section 5.0)
- Internals should be clean and dry.
- Ensure terminals are intact and secure.
- Heating element insulation resistance to be at least 2MΩ. Please refer to section 3.0 for further information
- Refit cover with new gasket or 'O' ring if required (refer to section 5) and re-tighten using only the socket head screws provided.

- Check the flamepath gap on the HFT & AFT Thermostats (As section 5.0)
- Earth continuity must be maintained between all earth points and main structure.

8.7.4 Annually

- Carry out 3 monthly and 6 monthly checks as above.
 - Check for element failure or low insulation resistance, as section 3.0
- 8.8 Only Exheat Industrial Ltd can carry out rod type element replacements in hazardous area heaters, any unauthorised modifications will invalidate the hazardous area certification and any warranty.
- 8.9 If equipment is being left unused for a period greater than 3 months, carry out 6 monthly maintenance before energizing.

9.0 MARKINGS

9.1 FAW, FAW-C & FCR Range:

 II 2 G

Ex e IIC T4 to T2 Gb

9.2 FAW-C-T and FCR-A (with Integral Thermostat):

 II 2 G

Ex d e IIC T4 to T2 Gb

9.3 HFT Type Thermostat used with Integral Thermostat Option, or Stand Alone type:

 II 2 G

Ex d IIC T6 Gb

9.4 AFT Type Thermostat. (Stand Alone Externally Adjustable):

 II 2 G D

Ex d IIC T6 Gb

Ex t IIIC T85°C Db

10.0 CERTIFICATION

10.1 FAW, FAW-C & FCR Ranges

ATEX: LCIE 00 ATEX 6013 X

IECEX: IECEX LCI 07 0009 X

10.2 HFT Type Thermostat and AFT Type (Externally Adjustable)

ATEX: LCIE 99 ATEX 6017 X

IECEX: IECEX LCI 07 0003 X

10.3 STW Range Air Warmers

No Certificates as these are Safe Area Heaters.

10.4 SAT40 & SAT60

No Certificates as these are Safe Area Thermostats.

APPENDIX A - WIRING DIAGRAMS

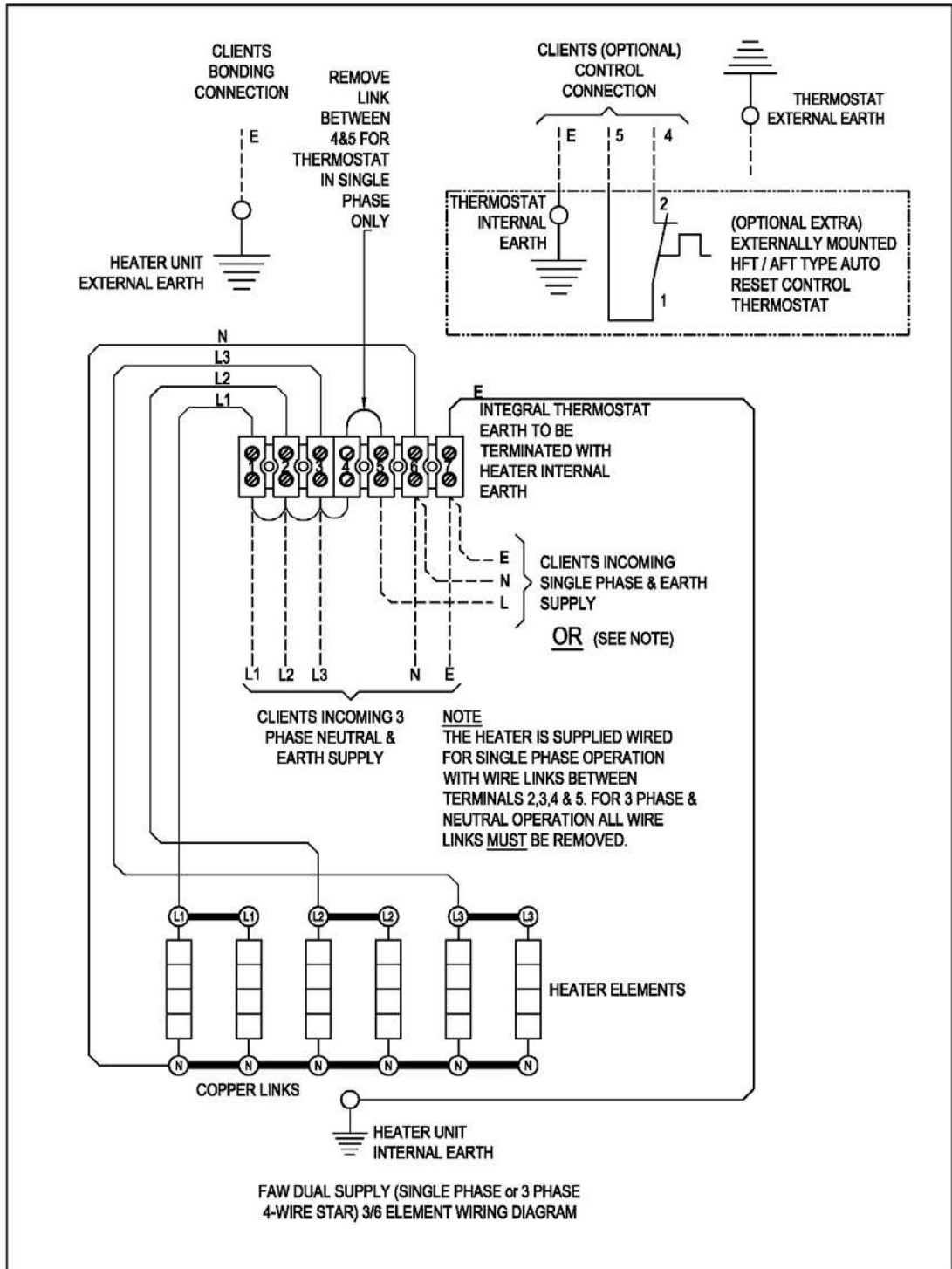

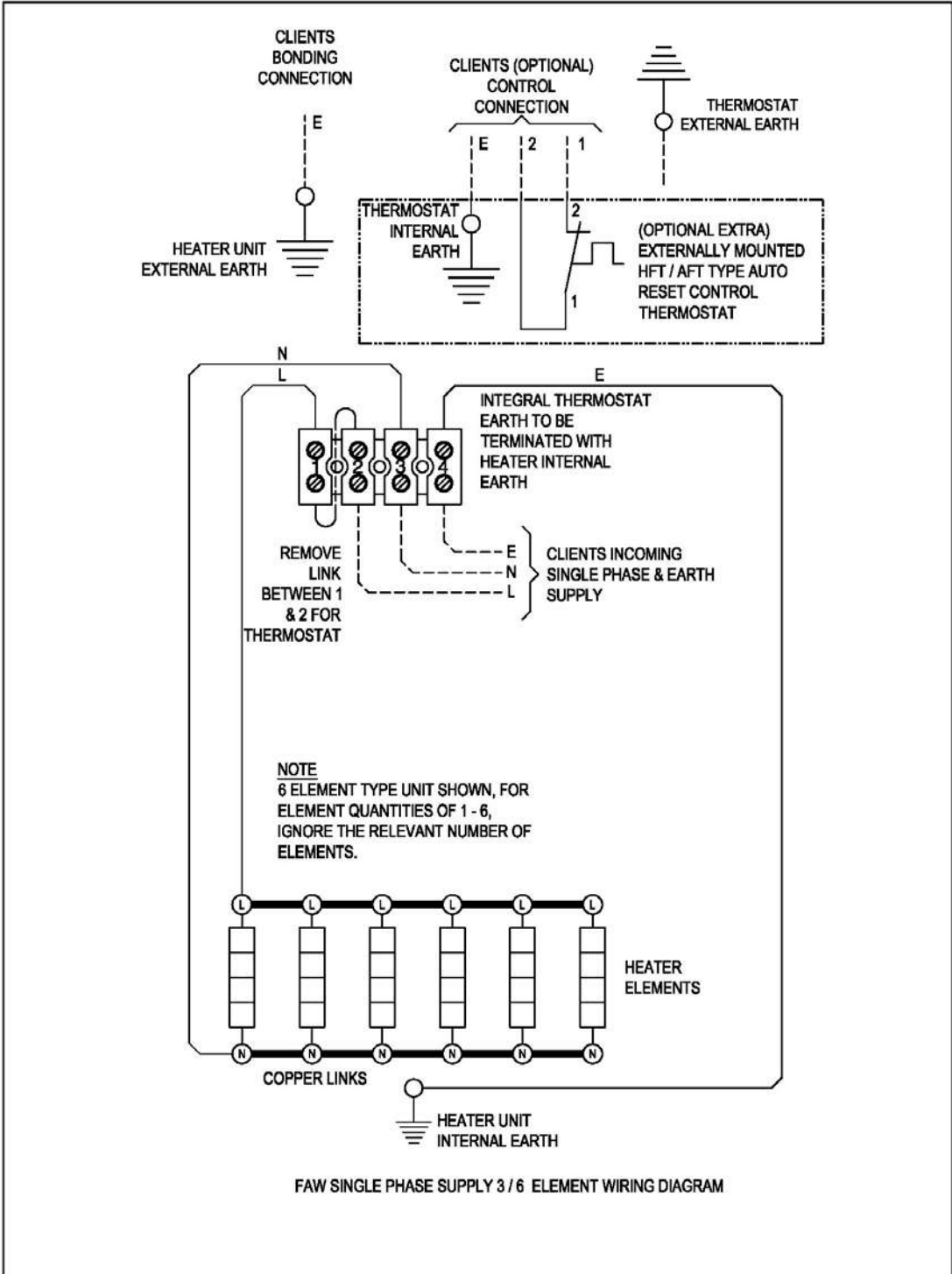

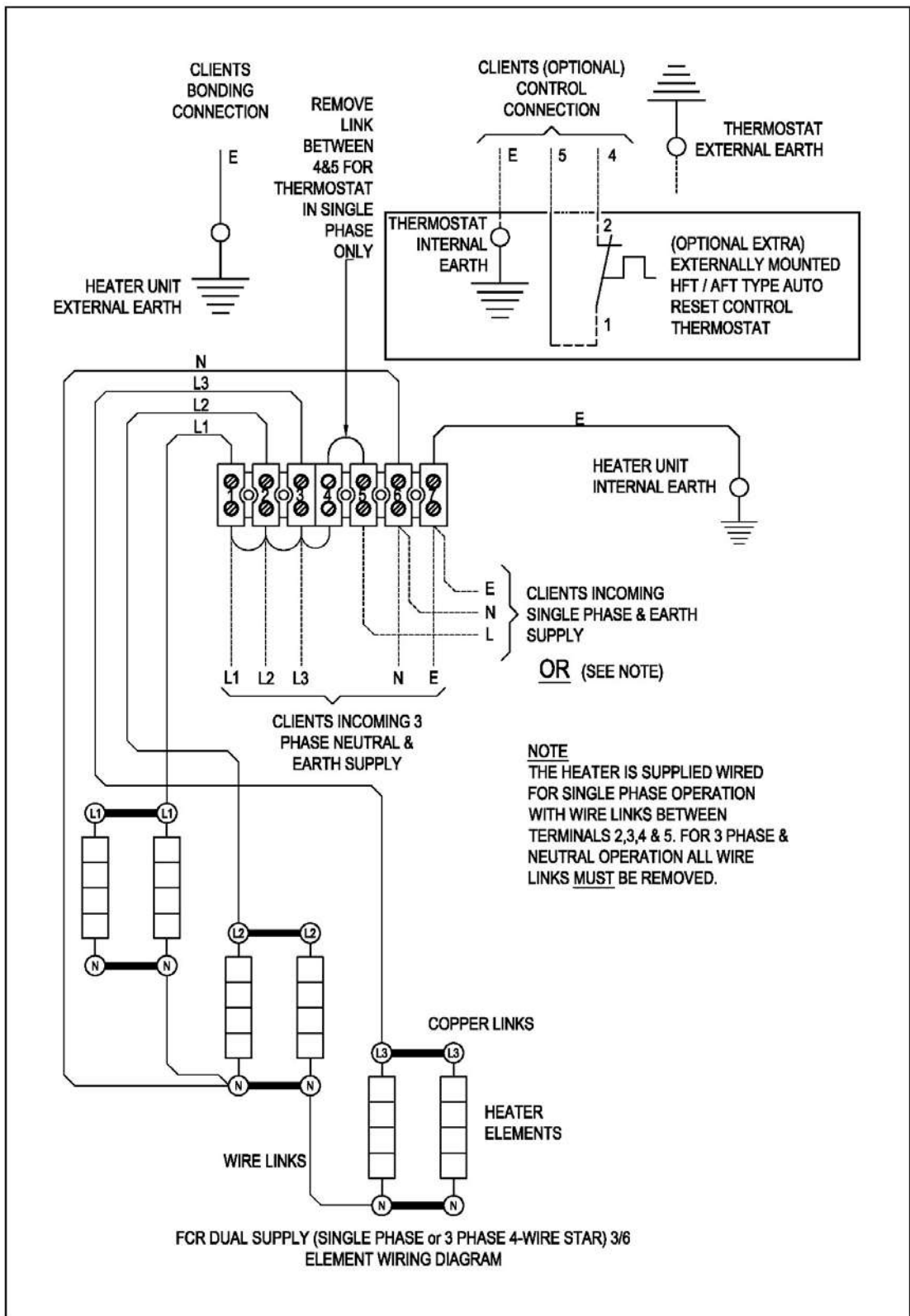

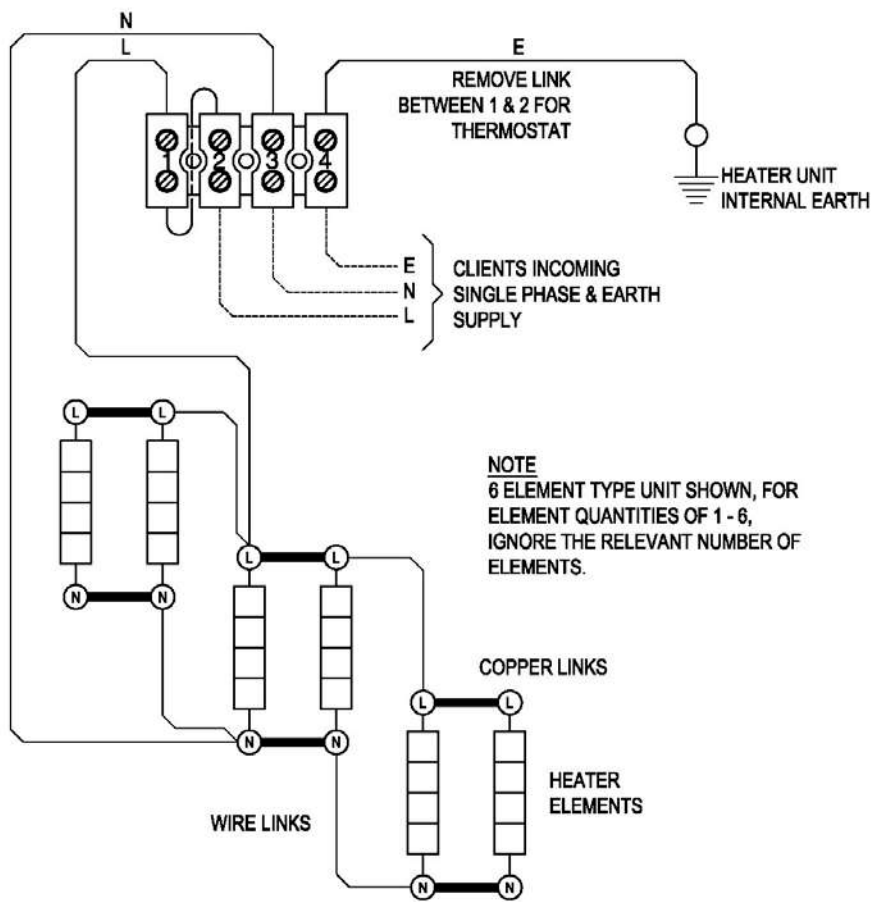
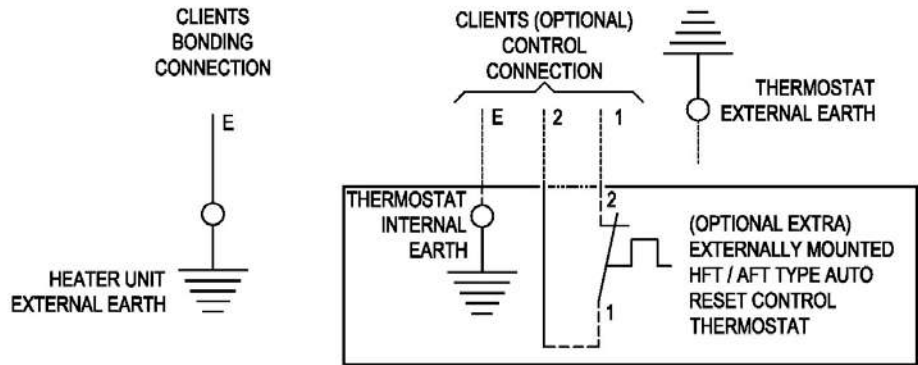

FCR SINGLE PHASE SUPPLY 3 / 6 ELEMENT WIRING DIAGRAM

FAW -C250

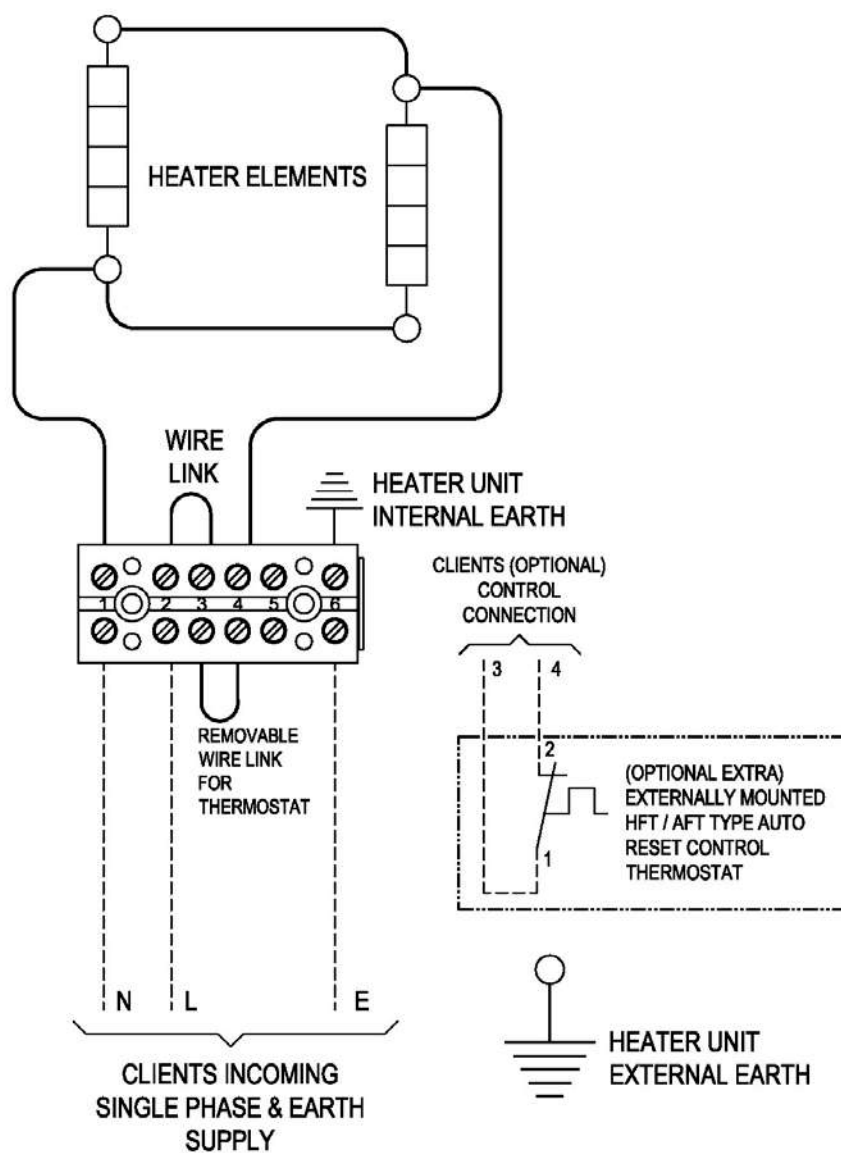

FAW-C500 & FAW-C1000

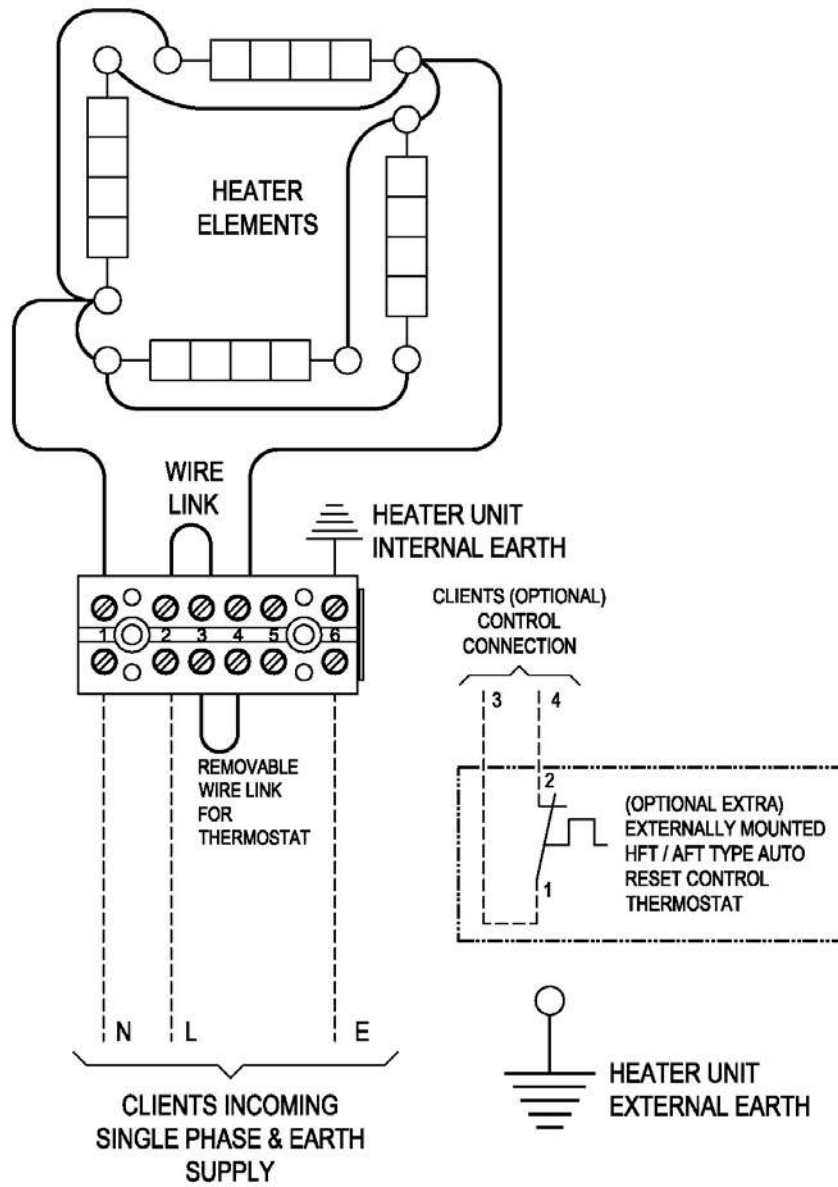

FAW-C750

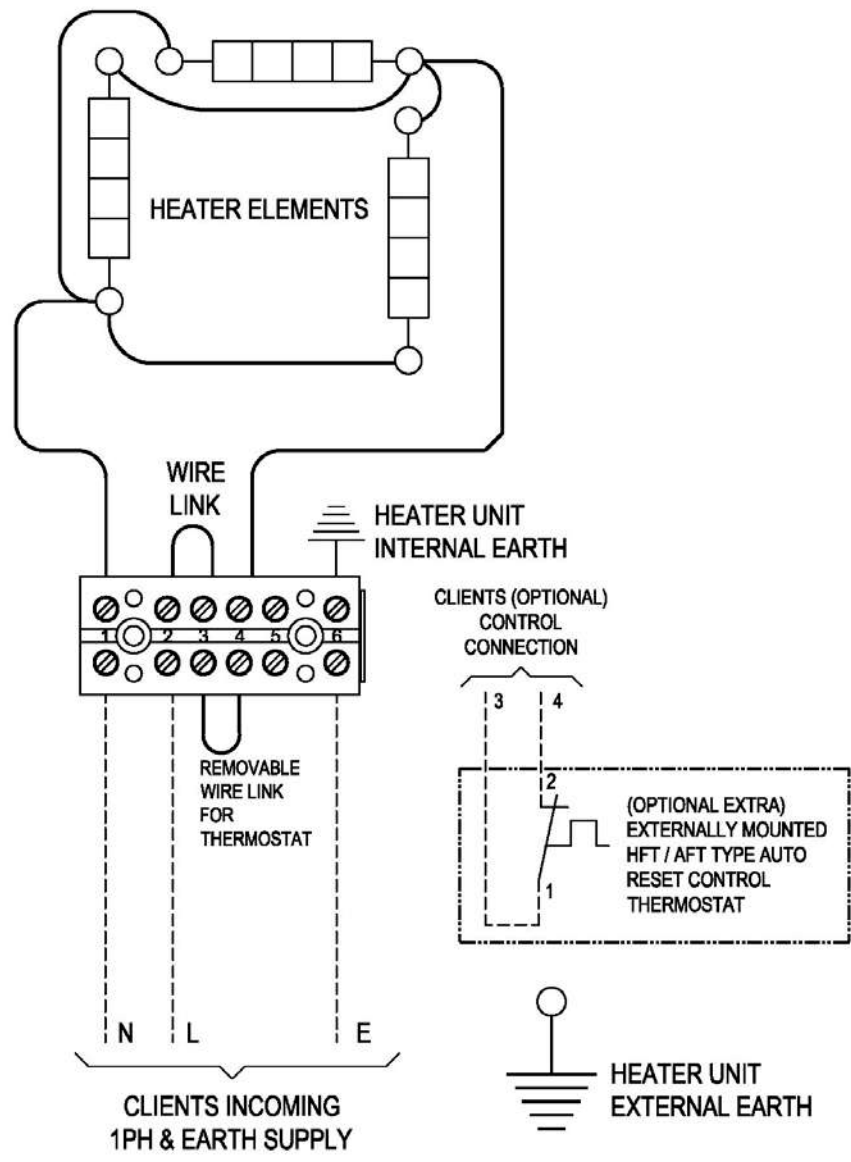

FAW-C750 3 PHASE SUPPLY

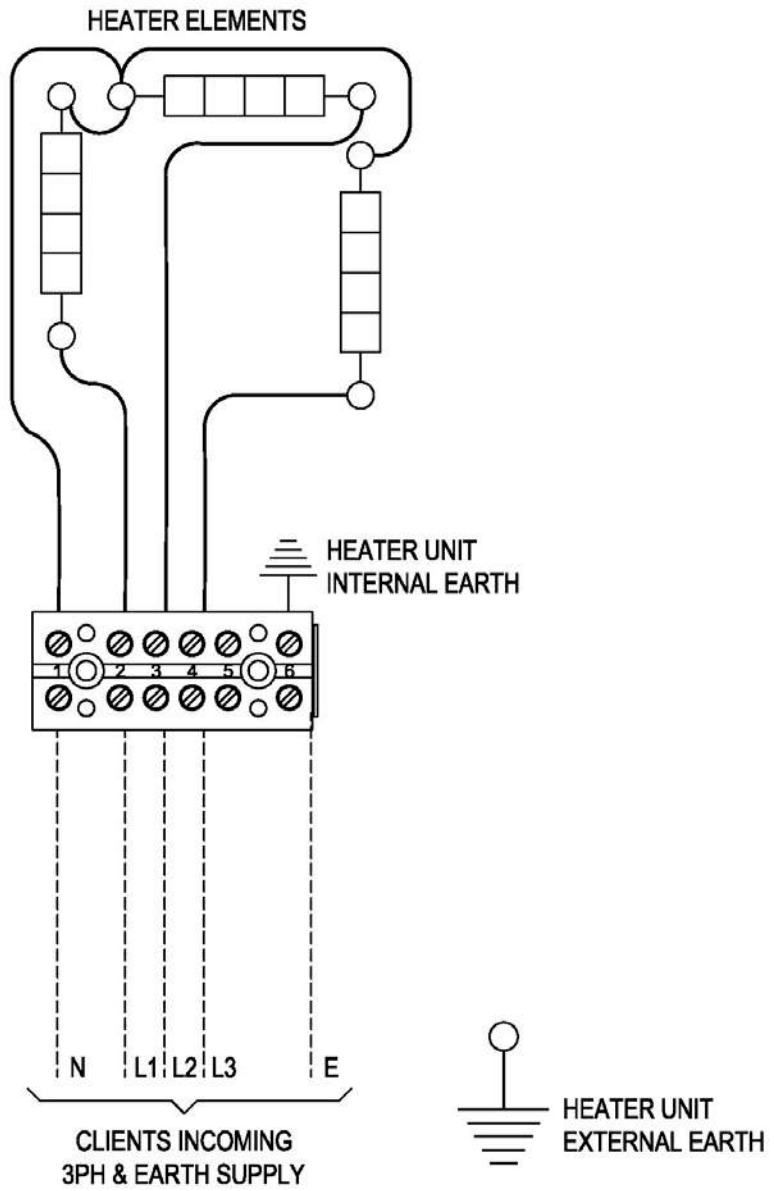

AFT40 & AFT60 THERMOSTAT

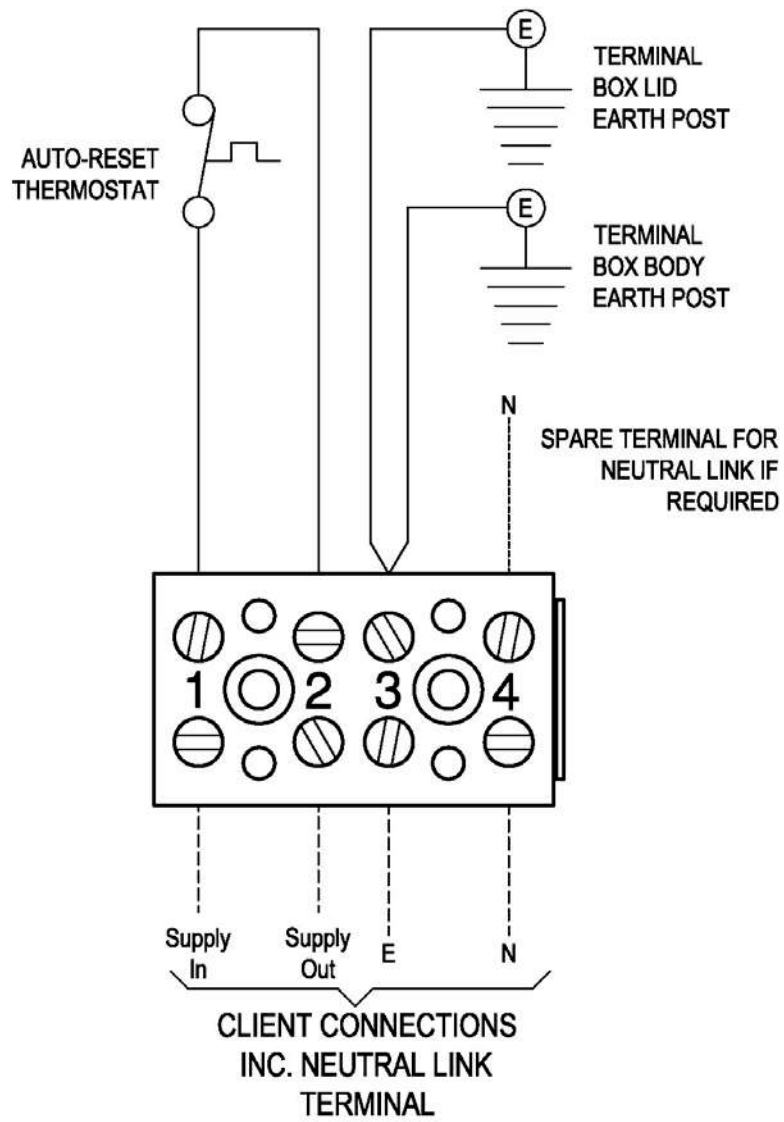

HFT / SAT 40 THERMOSTAT

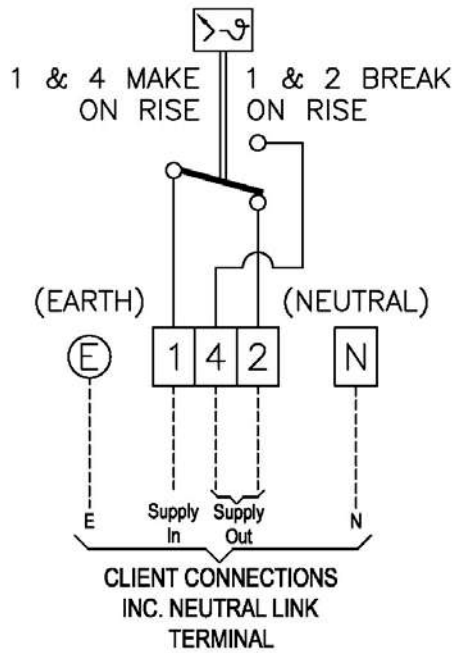

HFT / SAT 60 THERMOSTAT

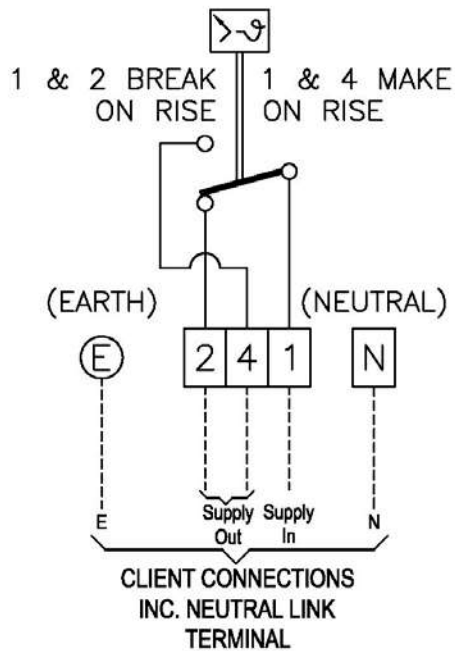

STW WIRING DIAGRAMS

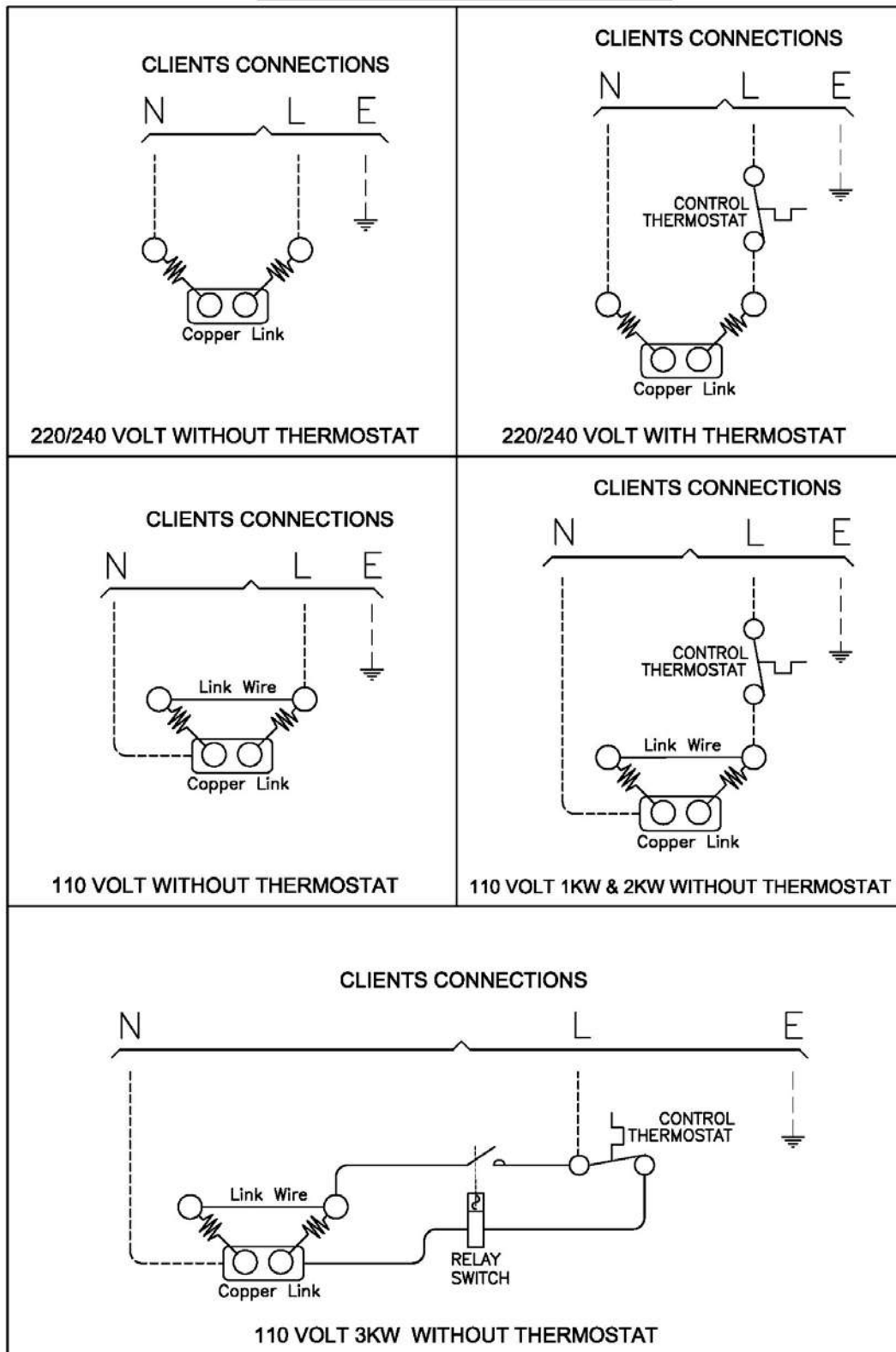

APPENDIX B, HEATER GENERAL ARRANGEMENT DRAWINGS.

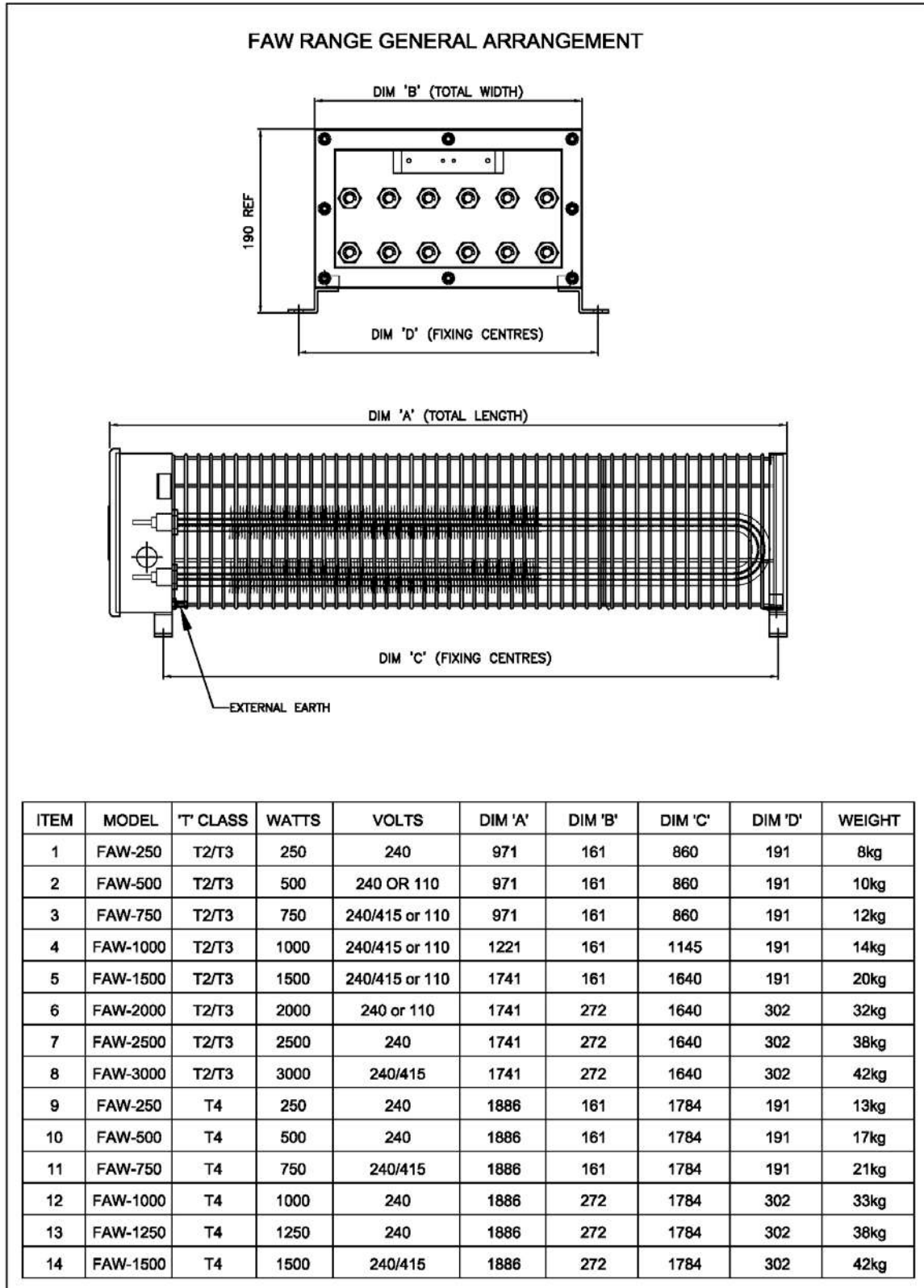

FAW-C & FAW-C-T GENERAL ARRANGEMENT

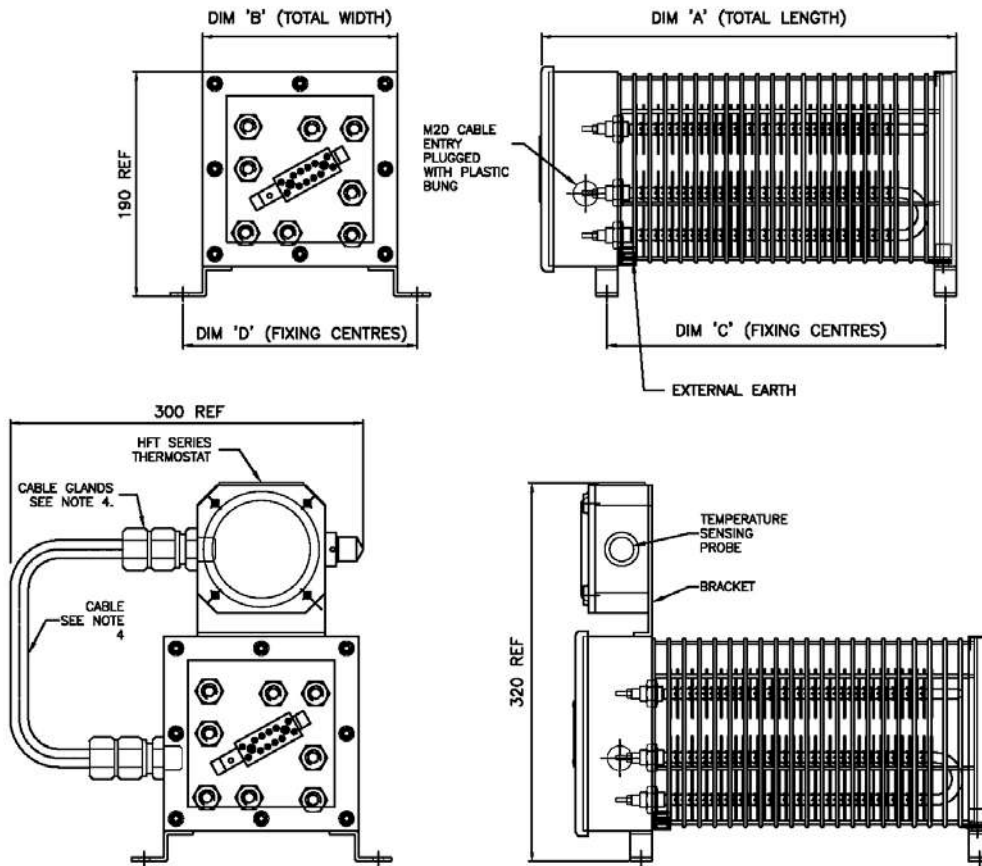

ALL DIMENSIONS OF HEATER AS PER BELOW

ITEM	MODEL	T' CLASS	WATTS	VOLTS	DIM 'A'	DIM 'B'	DIM 'C'	DIM 'D'	WEIGHT
1	FAW-C-250	T2/T3	250	110/240	350	161	282	193	5kg
2	FAW-C-500	T2/T3	500	110/240	350	161	282	193	6kg
3	FAW-C-750	T2/T3	750	110/240	615	161	545	193	8kg
4	FAW-C-1000	T2/T3	1000	110/240	615	161	545	193	9kg
5	FAW-C-250-T	T3	250	110/240	350	161	282	193	7kg
6	FAW-C-500-T	T3	500	110/240	350	161	282	193	8kg
7	FAW-C-750-T	T3	750	110/240	615	161	545	193	10kg
8	FAW-C-1000-T	T3	1000	110/240	615	161	545	193	11kg

FCR GENERAL ARRANGEMENT

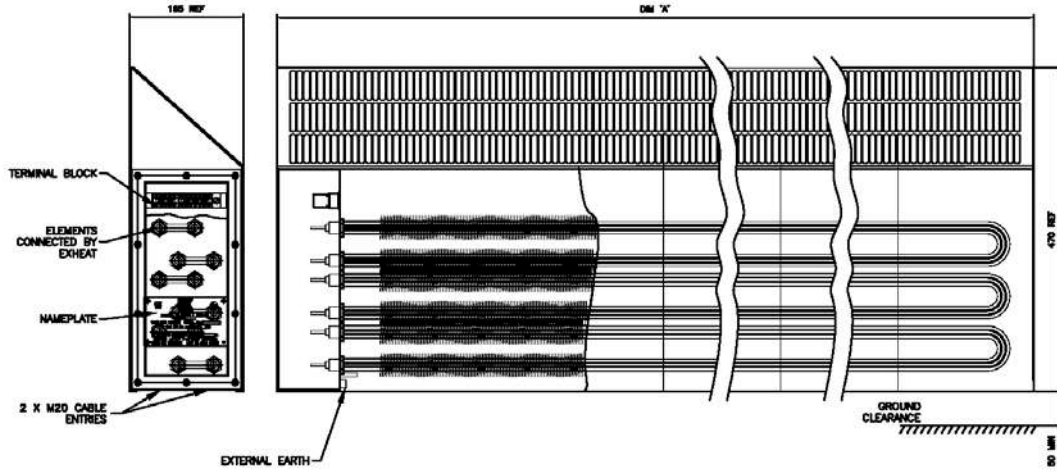

VIEW WITH OPTIONAL HFT

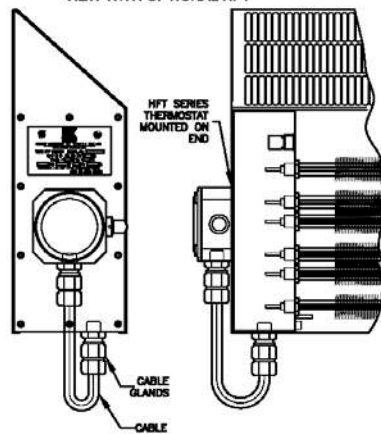

ITEM	MODEL	WATTS	No OF ELEMENTS	VOLTS	WEIGHT	DIM 'A'
1	FCR-1-110	1000	3	110	17kg	1240mm
2	FCR-1-110-A	1000	3	110	17kg	1240mm
3	FCR-1-240	1000	3	240/415	17kg	1240mm
4	FCR-1-240-A	1000	3	240 ONLY	17kg	1240mm
5	FCR-2-110	2000	6	110	32kg	1240mm
6	FCR-2-110-A	2000	6	110	32kg	1240mm
7	FCR-2-240	2000	6	240/415	32kg	1240mm
8	FCR-2-240-A	2000	6	240 ONLY	32kg	1240mm
9	FCR-3-240	3000	6	240/415	47kg	1750mm
10	FCR-3-240-A	3000	6	240 ONLY	47kg	1750mm

HFT TYPE THERMOSTAT GENERAL ARRANGEMENT

VIEW WITH TERMINAL BOX LID REMOVED

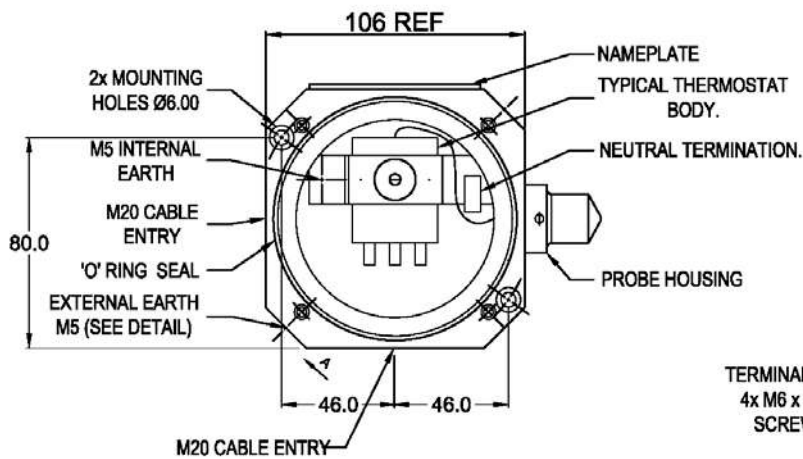

SIDE VIEW WITH TERMINAL BOX LID REMOVED

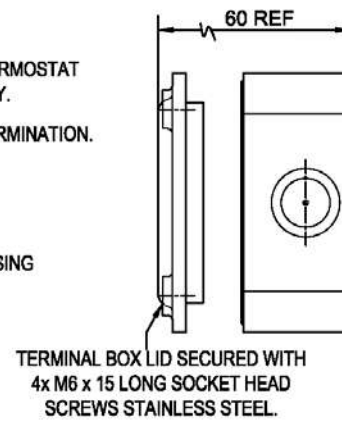

VIEW IN DIRECTION 'A' SHOWING EXTERNAL EARTH.

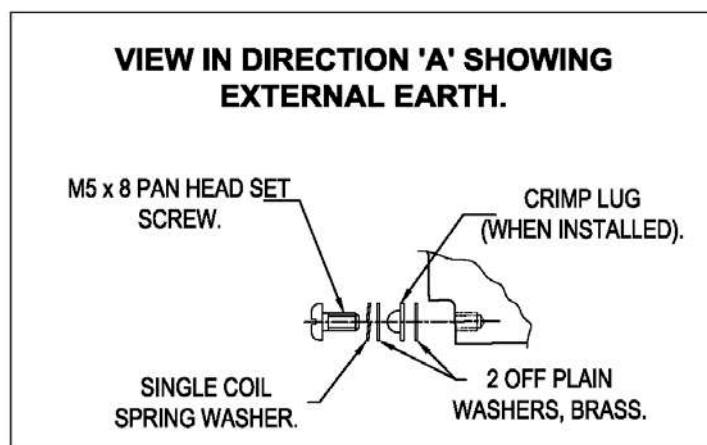

AFT TYPE THERMOSTAT GENERAL ARRANGEMENT

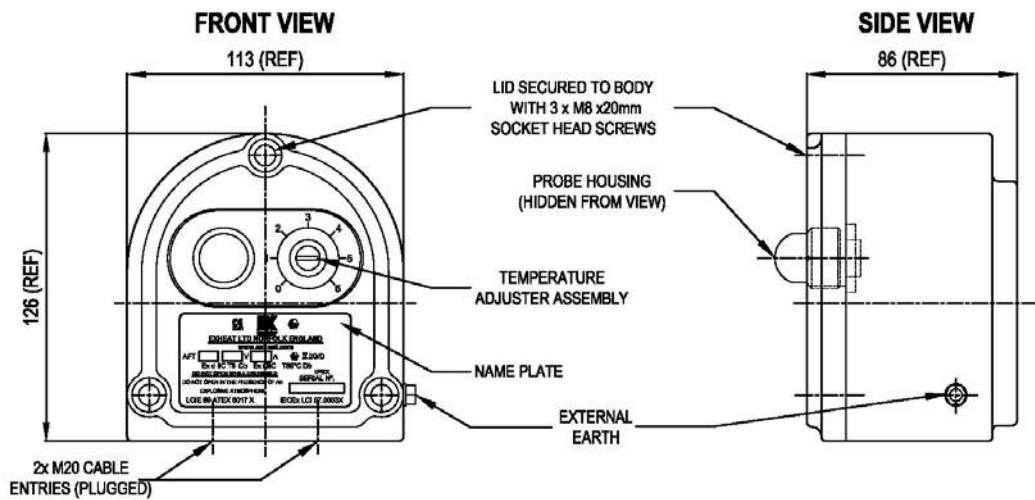

TERMINAL BOX FRONT VIEW (WITH LID REMOVED) SHOWING TERMINAL BLOCK ASSEMBLY AND FIXING HOLES

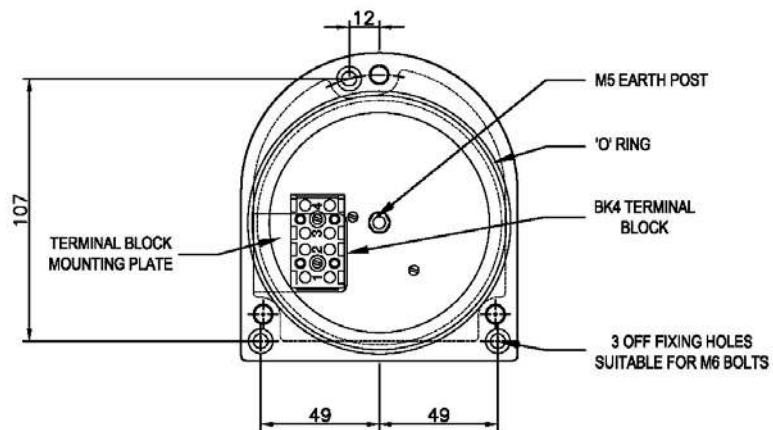

SAT TYPE SAFE AREA THERMOSTAT GENERAL ARRANGEMENT

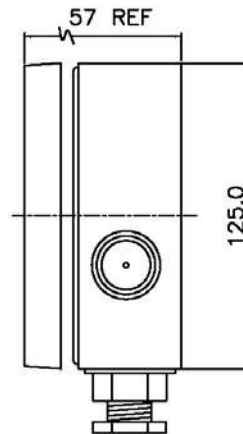
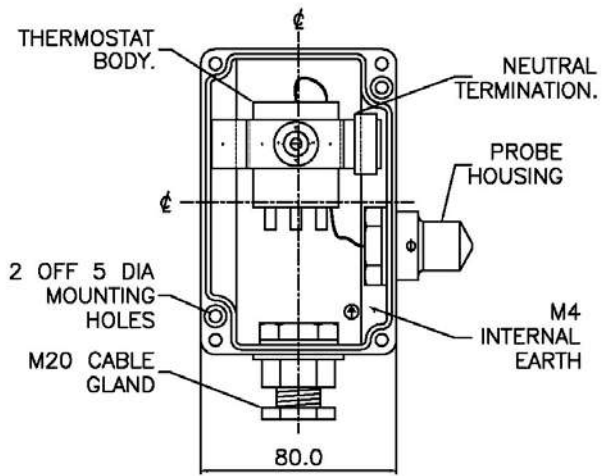

STW & STW-T GENERAL ARRANGEMENT

TOP VIEW

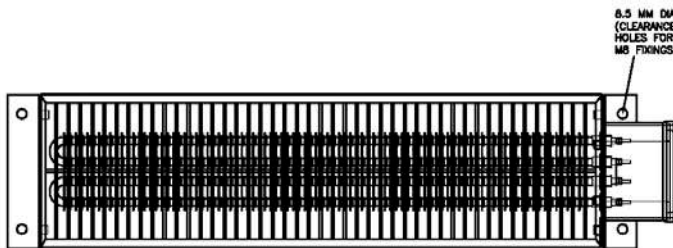

WALL MOUNTED

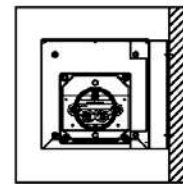

SIDE VIEW

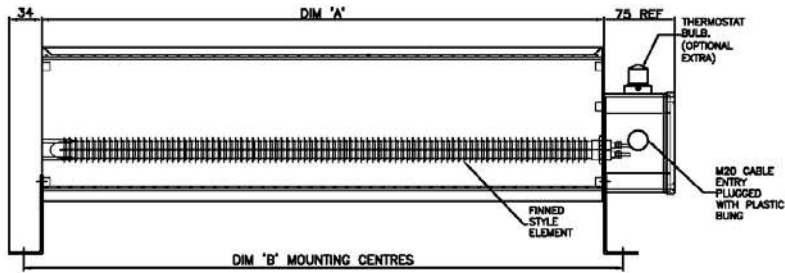

END VIEW

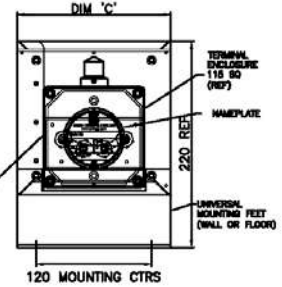

ITEM	MODEL	WATTS	VOLTS	DIM 'A'	DIM 'B'	DIM 'C'	WEIGHT
1	STW1	1000	110/240	500	540	160	6kg
2	STW2	2000	110/240	1000	1040	160	12kg
3	STW3	3000	240 ONLY	1500	1540	160	18kg
4	STW1T	1000	110/240	500	540	160	6kg
5	STW2T	2000	110/240	1000	1040	160	12kg
6	STW3T	3000	240 ONLY	1500	1540	160	18kg

EXHEAT INDUSTRIAL LTD



THORNE &
DERRICK
INTERNATIONAL

Thorne & Derrick
+44 (0) 191 410 4292
www.heatingandprocess.com

Author: P. Bumstead

Issue Date: April, 2019

Issue K_English

A4 printable version available on our website:

www.exheat-industrial.com/product



THORNE &
DERRICK
INTERNATIONAL

Thorne & Derrick
+44 (0) 191 410 4292
www.heatingandprocess.com