

# Safe use and handling of flammable liquids



**HSG140 (Second edition) Published 2015**

This guidance is for those responsible for the safe use and handling of flammable liquids in all general work activities, small-scale chemical processing and spraying processes.

It explains the fire and explosion hazards associated with flammable liquids and will help you determine how to control the risks in your workplace.

The guidance is one of three documents dealing with fire and explosion hazards associated with flammable liquids. The other two are:

- *Storage of flammable liquids in containers* HSG51;
- *Storage of flammable liquids in tanks* HSG176.

It supplements the advice contained in *Dangerous substances and explosive atmospheres: Dangerous Substances and Explosive Atmospheres Regulations 2002. Approved Code of Practice and guidance* L138.

The revised document incorporates information and cites relevant standards in relation to other publications which have been withdrawn.

# Contents

## **Introduction 4**

- Dangerous Substances and Explosive Atmospheres Regulations 2002 (DSEAR) 6
- General fire safety legislation 6
- Risk assessment 6

## **Hazards 8**

- Common causes of incidents 8
- Flammable vapours 9

## **Safety measures 11**

### **Control measures 12**

- Elimination and substitution 12
- Containment 12
- Ventilation 12
- Control of potential ignition sources and hazardous area classification 13

### **Mitigation measures 20**

- Separation 20
- Personal protective equipment (PPE) 20

### **General safety measures 21**

- Design and construction 21
- Maintenance and modifications 21

### **Cleaning and housekeeping 23**

- Control of spills 23
- Disposal 24

### **Emergency procedures 26**

- Leaks and spillages 27
- Firefighting equipment 27
- Environment 27

### **General fire precautions 28**

- Detection and giving warning in case of fire 29
- Adequate means of escape 29
- Suitable means of fighting fire 29

### **Information and training 30**

- Signage 30

### **Examples of processes and arrangements 32**

- Bulk handling of flammable liquids 32
- Small-scale dispensing and decanting 37
- Spraying and coating processes 39

**Appendix 1 Physical barriers of fire-resisting construction 43**

**Appendix 2 Mechanical exhaust ventilation (MEV) 44**

**Appendix 3 Other relevant health and safety legislation 45**

Management of Health and Safety at Work Regulations 1999 (the Management Regulations) 45

Control of Substances Hazardous to Health Regulations 2002 (COSHH) 45  
CLP and CHIP 45

Provision and Use of Work Equipment Regulations 1998 (PUWER) 46

Equipment and Protective Systems Intended for Use in Potentially Explosive Atmospheres Regulations 1996 (EPS) 46

Planning (Hazardous Substance) Regulations 1992 46

Dangerous Substances (Notification and Marking of Sites) Regulations 1990 (NAMOS) 46

Control of Major Accident Hazards Regulations 1999 (COMAH) 46

Consulting employees and safety representatives 47

Electricity at Work Regulations 1989 47

Carriage of Dangerous Goods and Use of Transportable Pressure Equipment Regulations 2009 (CDG) 47

Health and Safety (Safety Signs and Signals) Regulations 1996 47

Health and Safety Enforcing Authority Regulations 1998 48

Food and Environment Protection Act 1985 (FEPA) 48

Petroleum (Consolidation) Regulations 2014 48

**References 49**

**Glossary 52**

**Further information 55**

# Introduction

1 This guidance is for those responsible for the safe use and handling of flammable liquids in all general work activities, small-scale chemical processing and spraying processes. It provides information on the fire and explosion hazards associated with flammable liquids and sets out practical measures to protect people at work and others who may be affected by work activities involving flammable liquids.

2 The guidance is one of three documents published by HSE dealing with the fire and explosion hazards associated with flammable liquids. The other two documents are:

- *Storage of flammable liquids in containers* HSG51;<sup>1</sup>
- *Storage of flammable liquids in tanks* HSG176.<sup>2</sup>

3 This document complements *Dangerous substances and explosive atmospheres: Dangerous Substances and Explosive Atmospheres Regulations 2002. Approved Code of Practice and guidance* L138.<sup>3</sup> You will be referred to L138 for additional information.

4 The guidance will also provide a useful source of reference for:

- employees;
- employee-elected representatives;
- trade union appointed health and safety representatives; and
- all other people who have a role in ensuring and assessing the adequacy of health and safety in the workplace.

5 The guidance may also be useful to professional bodies, trade organisations and associations, and other safety specialists to inform the development of more specific guidance for their own members.

6 The objectives of this guidance are to:

- increase awareness of the potential fire and explosion hazards associated with flammable liquids;
- advise on safe operating procedures and precautions to reduce injuries and damage caused by fires and explosions while handling flammable liquids;
- give guidance on appropriate standards for plant and equipment;
- advise on the need for appropriate fire precautions, maintenance, training and good housekeeping where flammable liquids are handled or used.

7 In this guidance, 'flammable liquid' means a liquid with a flashpoint of 60 °C or below. This reflects the EU Classification, Labelling and Packaging of Substances and Mixtures Regulation (no 1272/2008) (the CLP Regulation), which sets the criterion for substances and mixtures to be classified as flammable to be those with a flashpoint of up to 60 °C. See Appendix 3 for more information on CLP.

8 This guidance is specifically applicable to those flammable liquids handled above their flashpoint. Primarily this will be flammable liquids categorised under CLP as:

- Category 1: flashpoint <23 °C and initial boiling point ≤35 °C; and
- Category 2: flashpoint <23 °C and initial boiling point >35 °C.

9 However, it also potentially includes:

- Category 3 flammable liquids (under CLP): flashpoint  $\geq 23$  °C and  $\leq 60$  °C; and
- combustible liquids with a flashpoint above 60 °C;

where as a consequence of environmental or workplace operational conditions it is reasonably foreseeable they may be handled above their flashpoint. In such circumstance, a similar fire and explosion hazard can exist to that presented by the handling of Category 1 and 2 flammable liquids.

10 For Category 3 flammable liquids that under normal environmental or workplace operational conditions will always be handled at temperatures below their flashpoint and in consequence will not produce a flammable atmosphere, not all the practical measures described in this guidance may be necessary. This guidance discusses those appropriate in this circumstance.

11 This guidance does not apply to flammable liquids which present special hazards requiring specific precautions, eg ethylene oxide, peroxides, and other liquids which carry a risk of rapid decomposition, polymerisation or spontaneous combustion.

12 This guidance provides a suitable standard for the design of new installations and for major modifications to existing installations. It may be difficult to adopt all the recommendations at existing premises, but any improvements that are reasonably practicable should be made, taking into account the hazards at the site and the cost and feasibility of additional precautions. This document describes ways of achieving an adequate standard of safety. Individual circumstances, for both new and existing installations, may require variations from the recommendations. Alternative designs, materials and methods can be used, as long as they provide an equivalent level of safety. Advice on applying the guidance to specific sites may be obtained from the relevant trade association or a health and safety professional.

13 This guidance primarily deals only with risks to people from flammable liquids. However, the release of flammable liquids and their vapours may also have consequences for the environment. In assessing the risk for the storage and handling of flammable liquids, including the development of emergency arrangements, the potential for releases of flammable liquids and vapours to cause environmental harm should also be considered. Many of the safety measures recommended to prevent fires and explosions will also minimise the risks to the environment in the event of an incident. However, you should ensure the measures taken are sufficient to guard against harm to the environment. This is especially important when considering alternative safety measures to those discussed in this guidance.

14 Further guidance on environmental considerations is available from:

- the Environment Agency in England [www.environment-agency.gov.uk/business/sectors/wastemanagement.aspx](http://www.environment-agency.gov.uk/business/sectors/wastemanagement.aspx)
- the Scottish Environment Protection Agency (SEPA) in Scotland [www.sepa.org.uk/waste.aspx](http://www.sepa.org.uk/waste.aspx)
- Natural Resources Wales (NRW) Cyfoeth Naturiol Cymru <http://naturalresourceswales.gov.uk>

15 The main health and safety legislation relevant to sites handling flammable liquids is outlined below and other relevant health and safety legislation is listed in Appendix 3. For the latest information on health and safety legislation, visit the HSE website [www.hse.gov.uk](http://www.hse.gov.uk).

## **Dangerous Substances and Explosive Atmospheres Regulations 2002 (DSEAR)**

16 Avoiding fire or explosion at workplaces manufacturing, storing or using flammable liquids can be ensured by compliance with DSEAR. The primary purpose of DSEAR is to protect the safety of workers and others who may be at risk from dangerous substances that can cause a fire, explosion or similar energy-releasing event, such as a runaway exothermic reaction.

17 DSEAR is enforced by HSE or local authority inspectors, except at commercial premises holding a petroleum storage certificate (previously a petroleum licence) where the Regulations are enforced by Petroleum Enforcement Authorities (PEAs) in respect of any activities related to refuelling motor vehicles. At most workplaces, the local fire and rescue authority or the joint fire and rescue board for the area will enforce those parts of DSEAR that relate to general fire precautions (see below).

### **General fire safety legislation**

18 General fire safety requirements in the workplace in England and Wales are applied through the Regulatory Reform (Fire Safety) Order 2005 (SI 2005/1541). The Scottish equivalents are the Fire (Scotland) Act 2005 (2005 (asp 5)) and the Fire Safety (Scotland) Regulations 2006 (SSI 2006/456). The legislation consolidated and revoked legislation that previously covered general fire safety, including the requirement for fire certification. Current legislation requires the employer to carry out a risk assessment to determine the general fire safety requirements for their workplace and implement those requirements, including maintaining a general fire safety management plan.

19 General fire safety legislation is normally enforced by the local fire and rescue authority or in Scotland, the Scottish Fire and Rescue Service. However, there are other enforcing authorities for certain specific workplaces/worksites. HSE is the enforcing authority for general fire safety in shipbuilding and on most construction sites. The Office for Nuclear Regulation (ONR) is the enforcing authority for fire safety in licensed nuclear premises.

20 The requirements of regulations 1–6, 8, 9 and 11 of DSEAR, as they relate to general fire safety, are covered by general fire safety legislation, with enforcement responsibility falling to the relevant authority, depending on the activity at the premises.

### **Risk assessment**

21 In addition to the requirements under the Management of Health and Safety at Work Regulations (the Management Regulations) (see Appendix 3), where flammable liquids are intentionally present at the workplace, there is a specific requirement under DSEAR for you to identify the potential risks such activity may pose to your employees and others whose health and safety may be affected, and to determine the measures to be taken to eliminate or reduce these risks so far as reasonably practicable.

22 The risk assessment required under DSEAR may be carried out as part of the risk assessment requirements of the Management Regulations and general fire safety legislation, which follows the same approach as that used in health and safety legislation. In particular, given the need to take account of the presence of flammable liquids in the general fire safety risk assessment, you may find it of benefit to carry out the required risk assessments as a consolidated exercise.

23 A risk assessment should be carried out regardless of the quantity of flammable liquid present at the workplace, as it will enable you to decide whether existing measures are sufficient or whether any additional controls or precautions are necessary. As well as assessing the normal activities within the workplace, you will also need to assess non-routine activities, such as maintenance work, where there is often a higher potential for fire and explosion incidents to occur. If there is no risk to safety from fires and explosions, or the risk is trivial, no further action is needed. If there are risks, then you must consider what you need to do to comply fully with the requirements of DSEAR.

24 Further guidance on the risk assessment requirement under DSEAR is given in L138.

25 The DSEAR risk assessment is quite wide-ranging and includes a requirement to consider whether a flammable liquid needs to be present in the workplace and if so, whether it might be substituted for one that is less flammable, eg has a higher flashpoint. You also need to determine how the flammable liquid is to be stored and handled to ensure the risks are reduced so far as reasonably practicable. This includes the decision whether flammable liquids should be stored in tanks, or if storage in containers is acceptable. This guidance assumes that you have carried out these aspects of the DSEAR risk assessment.

26 The performance objectives and control measures described in this guidance reflect current and readily achievable good industrial practice and are intended to aid the task of minimising the risks associated with the use of flammable liquids. You are free to take alternative measures, or vary those described, if you have determined through your risk assessment that they provide at least an equivalent level of health and safety.

# Hazards

27 The main hazards from the use of flammable liquids are fire and explosion. For a fire or explosion to occur it requires three things to come together:

- flammable liquid;
- source of ignition; and
- air.

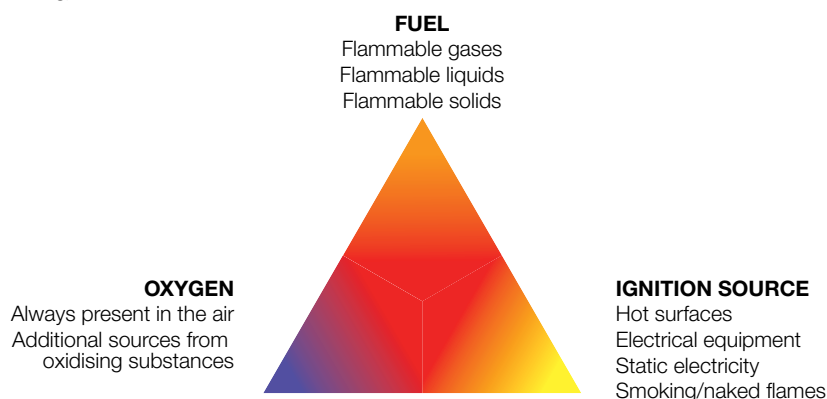

**Figure 1** The fire triangle

## Common causes of incidents

28 Fires or explosions can occur when vapours or liquids are released from a controlled environment to areas where there may be an ignition source, or, alternatively, when an ignition source is introduced into a controlled environment. Common causes of such incidents include:

- lack of training and awareness of the properties of flammable liquids;
- inadequate design of equipment;
- failure or malfunction of equipment;
- inadequate installation or maintenance;
- overheating flammable liquids, for example above the flashpoint, boiling point, auto-ignition temperature, or decomposition temperature;
- procedural errors or omissions;
- inadequate control of potential ignition sources, including electrostatic discharge;
- dismantling or disposal of plant and equipment that contains or has contained flammable liquid;
- hot work on or close to flammable liquid containers;
- exposure to heat from a nearby fire;
- incorrect use of solvents for cleaning operations;
- misuse of flammable liquids; for example, to burn waste material or 'brighten' fires.

29 Incidents involving flammable liquids commonly arise during transfer operations, including:

- movement from storage and within premises;
- decanting and dispensing;
- process activities;
- emptying plant and equipment, including vehicle fuel tanks prior to maintenance;
- disposal;
- dealing with spillages.



## **Flammable vapours**

30 Combustion of liquids occurs when flammable vapours released from the surface of the liquid ignite. The flashpoint is the lowest temperature at which a flammable liquid gives off vapours in sufficient concentration to form an ignitable mixture with air near the surface of the liquid. Generally, a flammable liquid with a flashpoint below ambient temperature will always give off sufficient vapour to form an ignitable mixture. Ignitable mixtures are less likely to form from liquids with a flashpoint greater than the ambient temperature unless they are heated, mixed with low flashpoint materials or released under pressure as a mist or spray. However, flammable liquids below their flashpoint can also be readily ignited if present as a thin film over a surface, even one that is non-combustible, or when spilt onto absorbent material such as clothing or packaging material.

31 The amount of flammable vapour given off from a liquid, and therefore the extent of the ignitable flammable vapour mixture with air, depends on a variety of factors, including the temperature of the liquid, its volatility, the surface area of the liquid exposed, how long it is exposed for, and air movement in the locality.

32 The extent of the ignitable mixture is referred to as the explosive atmosphere, ie the mixture of flammable vapour with the air, which has the potential to catch fire or explode. An explosive atmosphere does not always result in an explosion but, if it does catch fire, the flames will travel quickly through it. If this happens in a confined space (eg within plant or equipment, or a compartment, room or building), the rapid propagation of the flames through the explosive atmosphere may result in an increase in pressure and subsequent damaging explosion.

## **Explosion limits**

33 The explosion limits define the concentrations (normally by volume) of vapour/air mixtures that will propagate a flame. The lower explosion limit (LEL) is the minimum concentration of vapour in air below which propagation of a flame will not occur in the presence of an ignition source. This may also be referred to as the lower flammable limit or lower explosive limit. The upper explosion limit (UEL) is the maximum concentration of vapour in air above which the propagation of a flame will not occur. This may also be referred to as the upper flammable limit or the upper explosion limit.

34 The explosion limits vary for different flammable liquids, with typically many in the range of circa 1% (LEL) to perhaps between 10 and 20% (UEL). While flames will not propagate through flammable vapour mixtures with air above their UEL, they are still readily ignitable at their interface with air; in which event, a fire will result.

## **Vapours**

35 Some mixtures (preparations) that contain a flammable liquid (for example, water/solvent mixtures or emulsions) may only release flammable vapours slowly. However, the vapours may still achieve sufficient concentration to form an ignitable mixture with air and for the mixture to be assigned a flashpoint, even though the rate of vapour release may be insufficient to sustain combustion.

36 For such mixtures with a flashpoint  $<23$  °C (and those mixtures with a flashpoint above this but which as a consequence of environmental or workplace operational conditions it is reasonably foreseeable they may be handled above their flashpoint) the full implementation of the measures detailed in this guidance may not be necessary. This should be determined through the risk assessment, taking particular account of the advice and guidance available from the supplier, including the safety data sheet (SDS) for the mixture.

### **Viscosity**

37 Other physical properties, such as viscosity, auto-ignition temperature (AIT) and conductivity, also indicate the potential extent of an explosive atmosphere in relation to possible ignition sources.

38 The viscosity of the substance/mixture (preparation) determines how far any spillages will spread and therefore the size of any exposed surface of flammable liquid. Solvents generally have a low viscosity and when spilt, spread quickly allowing a rapid build-up of vapours from the surface of the liquid. Some liquid formulations, such as paints and resins, may have a high viscosity; if they are spilt they spread and produce vapours more slowly than would the individual solvent constituents.

### **Ignition**

39 The ignition energy required to ignite flammable liquid vapours is relatively small. The typical minimum ignition energy (MIE) is in the range of 0.1 to 10 mJ, which can be readily produced in much plant and equipment in the form of heat, electrical, mechanical or chemical energy.

40 In addition to the potential ignition sources presented by external plant and equipment, you should consider the properties of the flammable liquid itself to ensure it is not handled in a manner that might result in an incident. For example, to ensure it is not heated above its auto-ignition temperature; or where it has low (electrical) conductivity (ie less than 50 picoSiemens (pS)) it is handled in a manner to guard against incendive electrostatic discharge that is potentially capable of causing ignition of the flammable vapours.

### **Physical environment**

41 The physical environment in which flammable liquids are handled can also determine how the hazards may develop. Whether the released vapour is able to build up to form an explosive atmosphere will depend on whether it can freely disperse and if indoors the degree of ventilation of the enclosure, taking account of any obstructions and plant congestion that might interfere with this.

42 You should also consider the proximity of pits, gulleys and drains to where flammable liquids are stored and handled to ensure the ingress and accumulation of any releases of flammable liquids and/or vapours is prevented. Flammable liquid vapours are heavier than air and will, unless dispersed, tend to accumulate at lower areas. If ignition occurs in such locations, the flame is likely to travel or 'flash' back to the source of the vapours, ie the flammable liquid.

# Safety measures

43 The following safety measures apply to the handling and use of:

- extremely flammable liquids;
- highly flammable liquids; and
- those flammable liquids that may be handled at temperatures above their flashpoints (see paragraph 7).

44 For all other flammable liquids amendment and variation can be appropriate as determined by your risk assessment.

45 Where you have, through your DSEAR risk assessment, concluded that the handling of flammable liquids is appropriate at your workplace, DSEAR requires the following safety measures and procedures to be considered:

- control measures;
- mitigation measures;
- general safety measures;
- emergency procedures to be implemented in the event of an incident.

46 Control measures are those measures taken to prevent an incident from occurring. Mitigation measures are those measures taken should an incident occur to limit its extent and effect. General safety measures are those intended to ensure the workplace and facilities within this – along with the work processes – are designed, constructed and maintained to reduce the risks arising from the dangerous substance so far as reasonably practicable. The purpose of emergency procedures is to enable control or containment of an incident to allow sufficient time for people to escape or be evacuated to a place of safety; and following the incident, make the situation safe.

47 The following sections detail the safety measures which you may wish to consider when using flammable liquids.

# Control measures

## Elimination and substitution

48 DSEAR regulation 6 requires that where practicable, dangerous substances should be eliminated or substituted. The use of low flashpoint liquids should be avoided whenever practicable. Other liquids, which are either water-based or have a higher flashpoint, may provide suitable alternatives. However, risks to health or the environment should also be considered. In such cases, a judgement should be made which takes into account all the risks in the particular circumstances.

49 Where flammable liquids cannot be eliminated or substituted then only the minimum quantity necessary for the production activity should be used. Consider reducing batch sizes or replacing a batch process with a semi-batch process or by process intensification.

## Containment

50 Process and storage areas should be designed and operated to minimise risks. Pipework and closed vessels should be used rather than handling flammable liquids in containers and open tanks. This reduces the amount of liquids open to the air and reduces the risks from released vapours. It also reduces the risk of spillage.

51 Process vessels or areas need a means of containing spillages, such as a bund or retaining sill. Alternatively, the floor can be designed to drain into drainage channels leading to an interceptor or collection area. The containment arrangements should have sufficient capacity to contain any likely spill. Containment of firewater may also need to be considered (see paragraphs 140–142). Care is needed to ensure that, in the event of fire, the channels do not enable the fire to spread to other parts of the building or site. The drains from banded areas should not feed directly into the public system.

## Ventilation

52 All areas where flammable liquids are handled should be adequately ventilated to dilute any released vapours to a safe level. The ventilation should be sufficient to dilute the amount of vapour released to well below its flammable limit, and below the relevant occupational exposure limit. *Workplace exposure limits* EH40<sup>4</sup> gives advice on occupational exposure limits.

53 In some cases, good natural ventilation positioned predominantly at low level plus some at high level may be enough, but in others, mechanical ventilation and/or local exhaust ventilation will be needed. Guidance on local exhaust ventilation can be found in *Controlling airborne contaminants at work: A guide to local exhaust ventilation (LEV)* HSG258.<sup>5</sup> See also Appendix 2.

54 Ventilation systems should exhaust to a safe place in the open air. Requirements for positioning exhausts from ventilation systems may be found in process guidance notes issued by Defra.<sup>6</sup>

55 Electric motors used in ventilation ducting should not be situated in the path of the vapour being extracted. Centrifugal or bifurcated fans can be used, or a motor

situated in a safe area can be connected to a fan by a belt drive. Fans made from non-sparking materials provide an additional precaution against friction sparks. The ductwork itself should be fire-resisting (see BS 8313).<sup>7</sup>

56 Where the failure of an extraction system would entail a flammable concentration of vapour in the plant or an escape of toxic vapour, fit an airflow detector in the ducting (such as a differential pressure switch) linked to an alarm. Where it is reasonably practicable, the detector should also be interlocked with the vapour-producing process.

### **Ventilation of plant and machinery**

57 Plant and machinery containing dangerous substances should be provided with adequate ventilation to prevent hazardous explosive atmospheres from occurring so far as reasonably practicable. For plant and machinery purchased from within the EU, this should be confirmed by the supplier in compliance with their duties under the Machinery Directive 2006/42/EC implemented in UK law by the Supply of Machinery (Safety) Regulations 2008 (SI 2008/1597). Documentary information should show that 'machinery is designed and constructed to avoid any risk of explosion posed by the machinery itself or by gases, liquids, dusts, vapours or other substances produced or used by the machinery'.

58 Where the plant or machinery is manufactured by the employer or imported from outside the EU, the employer takes on the responsibility for ensuring its safe design and use.

59 Plant and machinery should be properly installed to ensure the ventilation operates as designed and exhausts to a safe place, a recovery unit or a disposal unit.

60 Ventilation within process plant and machinery is normally considered adequate if it limits the average concentration of any dangerous substance that might potentially be present to no more than 25% of the LEL. However, an increase up to a maximum 50% LEL can be acceptable where additional safeguards are provided to prevent the formation of a hazardous explosive atmosphere. For example, gas detectors linked to emergency shutdown of the process might be used together with maintaining or increasing the exhaust ventilation on solvent evaporating ovens. See also Appendix 2.

### **Control of potential ignition sources and hazardous area classification**

61 Preventing leaks and the possible accumulation of dangerous quantities of flammable liquid or vapours is the first priority. However, you should anticipate that flammable liquids or vapours could still escape and have adequate and sufficient control measures in place to prevent their ignition.

62 Potential ignition sources can be of various forms of energy (including heat, electrical, mechanical and chemical) and may be presented by fixed and mobile plant and equipment, or transient activity. Examples include:

- naked flames, including welding and cutting equipment;
- smoking and smoking equipment;
- electrical lighting, power circuits and equipment;
- personal electrical equipment including mobile phones, computers and tablets;
- mechanically powered plant;

- processes that involve the generation of sparks;
- hot surfaces;
- static electricity;
- lightning.

Further advice can be found in BS EN 1127-1.<sup>8</sup>

### **Hazardous area classification**

63 Under regulation 7(1) of DSEAR, you must determine the potential extent of the flammable atmosphere that could result from leaks of flammable liquids handled at temperatures at or above their flashpoint (or where this might be anticipated) and ensure all potential ignition sources are excluded from such areas. This process is referred to as hazardous area classification (HAC), the requirements for which are detailed in L138 (see regulation 7 and Schedules 2–4).

64 Within these hazardous areas, only equipment and protective systems that are ATEX certified in compliance with the Equipment and Protective Systems Intended for Use in Potentially Explosive Atmospheres Regulations 1996 (EPS) should be used.

65 Further advice and guidance on HAC includes:

- BS EN 60079-10-1;<sup>9</sup>
- Energy Institute's *Model Code of Safe Practice Part 15: Area Classification Code for Installations Handling Flammable Fluids*;<sup>10</sup>

66 Where a hazardous area classification study has been carried out under regulation 7 of DSEAR, this should be recorded in the form of a drawing which:

- identifies the hazardous areas and types of zones;
- shows the extent of the zones in both plan and elevation (ie illustrates the three-dimensional nature of the hazardous zone);
- is supplemented with relevant information as to the flammable liquids that it applies to.

67 HAC is intended to consider those leaks that may be expected to occur during normal operational and maintenance activities, which include accidental spillage. However, you should also consider the full range and nature of the potential leaks that might occur and put in place appropriate measures to reduce the risk of ignition and escalation of a fire.

68 Similarly, you should also consider the possibility that a potential ignition source may be outside the designated hazardous areas defining the nominal extent of the explosive atmosphere; for example an incandescent particle from a fire, hot work, exhaust or possible plant failure. The risk of such occurrence should be reduced by appropriate plant design and control of work activities.

### **Electrical equipment**

69 Where possible, electrical equipment should be located in non-hazardous or safe areas. Any electrical equipment installed or introduced into hazardous areas should be constructed to a suitable explosion-protected equipment standard (that is, an appropriate British Standard or equivalent). The equipment should be suitable for the hazardous zone in which it is used. Advice on selecting, installing and maintaining explosion-protected electrical equipment is given in L138 and in:

- BS EN 13463-1;<sup>11</sup>

- BS EN 60079-14;<sup>12</sup> and
- BS EN 60079-0.<sup>13</sup>

70 Electrical equipment in hazardous areas should be controlled and maintained in line with the maintenance schedule. Unauthorised equipment such as radios, heaters, calculators and mobile phones should not be taken into hazardous areas.

71 Equipment such as flame arresters (see BS EN ISO 16852,<sup>14</sup> ROSOVs, pressure valves and explosion vents should, where necessary, also be ATEX certified, properly installed and suitably maintained.

### **Electrostatic charging**

72 Precautions should be taken to prevent vapours being ignited by the discharge of static electricity. The movement of process liquids, for example, during pumping, filtering, emptying, filling and spraying, can cause electrostatic build-up. Movement of other materials, such as powders or a printing web, or cleaning operations, can also create electrostatic hazards. Non-conducting footwear and clothing made of synthetic fibres can cause incendive electrostatic sparks, especially if they are worn in areas with non-conducting floors. A range of industry guidance is available (see [www.sia-uk.org.uk/health-and-safety.htm](http://www.sia-uk.org.uk/health-and-safety.htm)) and advice on static electricity may be found in PD IEC/TS 60079-32-1.<sup>15</sup>

73 To protect against electrostatic build-up, all metal (or other conducting) components must be adequately earthed before any liquid flow begins. All fixed equipment used to handle flammable liquids should be electrically bonded together and adequately earthed. Check earth continuity regularly (at least annually – see BS 7430.<sup>16</sup> Earthing contacts should be maintained and kept clean. Portable containers should also be earthed before use with bonding clips connected by a wire to the fixed earthed plant or by some other equally effective method.

74 Bear in mind any unearthed metal components in transfer systems, such as in valves, dispenser heads or sections of piping; these may need additional earthing straps. Other unearthed components may not be so obvious, or may result from poor maintenance. If uninsulated wire reinforcement (in damaged pipe lagging, for example) is left exposed it may build up electrostatic charges if it is subjected to steam from leaking joints. If hoses are used, they should be electrically continuous and bonded to both parts of the plant. Beware also of non-conducting tape used on screw joints as it can break the continuity of the metal-to-metal connection in the pipework.

75 Static electricity generated by flammable liquids should be reduced by avoiding the freefall of liquids and restricting pumping speeds. Plant should be designed and procedures should be in place to prevent splash filling of containers and process vessels. Additional care is needed for liquids with low conductivity up to and including 50 pS/m. The flow velocity in a pipe where a second phase may be present (such as gas, solid or an immiscible liquid such as water) should not exceed 1 m/s. Water may be present even if it has not been deliberately introduced (for example, condensate). PD IEC/TS 60079-32-1 and BS 5958-1<sup>17</sup> offer further advice for higher velocities. Anti-static additives can be used to increase the conductivity of flammable liquids with a conductivity less than 50 pS/m but this effect can deteriorate over time. In some cases, the use of a nitrogen blanket should be considered.

76 Take particular care when adding dry powders to vessels containing flammable liquids. The movement of dry powders and other solids over insulated materials such as plastics can quickly cause incendive electrostatic sparks. Dry powders should not

be added to process vessels containing flammable vapours using plastic scoops or plastic chutes, nor should they be discharged from plastic bags; if the vapours ignite, flames will be emitted from the vessel manhole directly onto workers.

77 Consider removing workers from activities which may put them at risk. This can be achieved by using measures such as:

- mechanical transfer systems; and
- double-valved hopper systems.

78 Other measures to prevent the generation and discharge of static electricity include:

- airlock and nitrogen purging;
- charging solids before solvent addition (ensure there are no residual vapours from previous use);
- wet or slurry solid before addition;
- addition of solvents with a high conductivity before ones with a low conductivity if both are to be present.

### ***Clothing***

79 Some clothing, including footwear, contains materials that can generate and accumulate electrostatic charge during use. The discharge sparks can ignite certain types of explosive atmospheres, eg gases or vapours and even some types of dust that are very easily ignited.

80 Employees working in these atmospheres should be provided with anti-static footwear if the assessment indicates an ignition risk. Providing the floor is not highly insulating, anti-static footwear alone may be sufficient to control the risk because the risk from electrostatic discharges from clothing can be reduced if the wearer is earthed by the footwear and suitable flooring such as concrete or steel grids. Anti-static footwear and flooring should be tested routinely and replaced if it is found that its anti-static properties have deteriorated.

### ***Friction sparks***

81 Flammable vapour may be ignited by friction sparks. These can be generated by tools (hand-operated or power-driven), or by operations involving rubbing or impact. Special tools made of nickel-aluminium bronze or similar alloys may reduce sparking, but pieces of grit or tramp metal becoming embedded in working surfaces can present problems. Spark-resistant tools need to be inspected regularly and the surfaces re-dressed as necessary. Do not rely on these tools alone in areas where flammable vapour may occur; as far as possible, remove flammable liquids, residues and vapour before carrying out operations that may cause a spark.

82 Light alloys such as aluminium can cause sparking when struck a glancing blow on rusty steelwork. A smear of such an alloy on a rusty surface can also create a very hot spark if struck by another piece of steel, for example, a hammer. Identify where such metals are in use, so that procedures can be controlled in areas where flammable materials may be present and where there is a risk of impact. Aluminium powders in paints can cause similar problems, and their use in areas where flammable materials are present should also be controlled.

### ***Protection of vehicles***

83 Lift trucks and similar vehicles working in areas designated as hazardous areas should be designed to an appropriate standard such as BS EN 1755.<sup>18</sup> The level of



protection should be in line with the hazardous area classification (see paragraphs 61–68). Where only liquids with a flashpoint higher than the ambient temperature are present, vehicle protection is not needed, as long as the liquids are not heated above their flashpoint (either directly or indirectly), nor likely to be released as a mist or spray.

### **Space heating**

84 Workrooms in which flammable liquids are handled should preferably be heated by indirect means, for example, radiators fed by hot water pipes. Where hot water radiators cannot be used, electrically heated radiators may be used, providing they have been selected according to, and comply with BS EN 60079-30-1.<sup>19</sup> Do not use heating which could be a source of ignition. The temperature of exposed surfaces should not exceed the auto-ignition temperature of any of the flammable liquids in use. In all cases, heating systems should be protected against the build-up of flammable residues on hot surfaces. Do not use portable heaters unless they comply with BS EN 60079-30. Combustion air for fuel-fired heaters should not be drawn from areas which could contain flammable vapours.

### **Hot work**

85 A major cause of incidents is hot work (welding, cutting or similar operations) carried out on vessels containing flammable vapour or liquid residues. Hot work should only be done under controlled conditions using a permit-to-work (PTW) system. This will include following site rules and instructions, and operating only when authorised by a responsible person. Hot work must not be carried out on an item that contains or has contained flammable liquid or vapour until the item is made safe.

86 Before hot work is carried out, drain off any flammable liquid. Gas free the vessel, and thoroughly clean and inspect it to ensure all residues have been removed. Gas freeing alone is not enough, as residues of heavy materials may give off flammable vapours when heated, and apparently 'empty' containers or vessels may contain small amounts of unseen liquids at the bottom or in crevices and seams. An alternative technique is to inert the vessel by filling it with water, nitrogen foam or nitrogen. Take great care throughout the operation to ensure that no voids containing flammable vapours can occur in the vessel.

87 A competent person should monitor the atmosphere with a suitable gas detector as part of the overall operation, to show the vessel is safe for hot work. Carry out this monitoring as proof of gas freeing, and also, when using gas inerting techniques, both before and during the hot work operation. If water is used, prevent pressure building up by providing a vent for steam. Wherever possible the item should be taken to the workshop, or a similar safe area, for both the cleaning/inerting operation and the hot work. Further advice on preparing plant for hot work is given in *The cleaning and gas freeing of tanks containing flammable residues* CS15.<sup>20</sup>

88 A range of advice on PTW systems is available on HSE's website [www.hse.gov.uk](http://www.hse.gov.uk) and in *Guidance on permit-to-work systems: A guide for the petroleum, chemical and allied industries* HSG250.<sup>21</sup>

### **Cold cutting**

89 Consider using 'cold-cutting' techniques as an alternative to hot work, particularly during demolition work, as they can significantly reduce the risk of fires and explosions. Cold-cutting methods include using:

- hydraulic- or pneumatic-powered cutters, nibblers, drills and saws;
- pneumatic chisels;

- high-pressure water jetting.

90 With some cold-cutting techniques the temperature and the possibility of sparks can be further reduced by applying water or other non-flammable liquids at the cutting edge. These methods may not completely remove the risk of ignition as, for example, pneumatic chisels can create friction sparks and water jetting may build up an electrostatic charge under certain circumstances.

91 Before using cold-cutting methods, consider the precautions discussed in paragraph 86 to control the formation of flammable atmospheres as well as the ignition energies of any flammable liquid vapours or solid residues. In general, the use of cold-cutting techniques generates less heat than hot work and so reduces the evaporation of any remaining flammable materials that are contaminating the plant. In particular, it prevents flammable atmospheres forming from high flashpoint liquids, including those with a flashpoint above 60 °C. These have been known to cause serious accidents as a result of the rapid vaporisation of the liquid during hot work with an oxyacetylene flame.

92 Other cutting methods using grinders or disc cutters, although not strictly classified as hot work, still produce a significant number of sparks that can easily ignite flammable vapours. Grinders and disc cutters should therefore only be used on plant that has contained flammable materials after carefully assessing the hazards and the required precautions.

### **Smoking**

93 Designated smoking areas should be located in a safe place, and clearly defined and signposted, not near to where flammable liquids are handled. Notices prohibiting smoking and naked lights should be clearly displayed in these areas. It is recommended that signs comply with BS 5499-10.<sup>22</sup> Any area set aside for smoking should be provided with adequate receptacles (preferably sand-filled) so that people can dispose of their smoking materials before exiting the area.

### **Segregation**

94 Flammable liquids should be kept away from incompatible substances. *Chemical warehousing: The storage of packaged dangerous substances* HSG71<sup>23</sup> gives guidance on the safe storage of incompatible chemicals and includes a useful schematic of segregation recommendations. Nor should stocks of combustible materials, such as packaging be left in the flammable liquid process area. Potentially, this could be the first material ignited, where a subsequent fire would then be likely to compromise the safety of the process area.

### **Security**

95 To minimise the risk of fire or explosion, appropriate precautions should be taken to prevent the uncontrolled or unauthorised access, including trespass, of the process area. These precautions should include appropriate arrangements to secure the site against trespass outside normal work hours, and in particular guard against the possibility of tampering, vandalism and arson.

96 The standard of security required will depend, among other factors, on the consequences of a fire or explosion. Access to process areas holding flammable liquids should be controlled. Security measures including CCTV, intruder alarms, security patrols etc may be appropriate.

97 The security measures adopted should not compromise other safety requirements. Adequate means of escape should be provided from fenced compounds, process buildings and storerooms. Ensure gates and doors designated as fire exits can be readily opened whenever the compound, building or storeroom is occupied (see General fire precautions, paragraphs 143–155).

# Mitigation measures

## Separation

98 Areas where flammable liquids are handled should normally be separated from other process or storage areas by fire-resisting partitions (see Appendix 1). Take care to ensure partitions do not restrict escape routes or exits. Where partitions will require a change to existing escape routes or exits the enforcing authority for the general fire precautions (see paragraphs 143–155) should be consulted. Areas where flammable liquids are used should also be fire-separated from areas where other flammable materials, of any type, are stored. Advice on the storage of dangerous substances in general is contained in HSG71. Advice on the storage of flammable liquids in containers is provided in HSG51.

## Personal protective equipment (PPE)

99 The provision of suitable personal and respiratory protective equipment (PPE/RPE) should not be a substitute for providing appropriate safety measures on the plant, facilities, equipment and work processes. The purpose of PPE, including RPE where needed, is to address any residual risk that remains after all appropriate safety measures have been implemented.

100 Where there is a risk of electrostatic discharge causing ignition, PPE (ie footwear and as appropriate, clothing) should be provided to guard against this risk. Risk assessment should also inform whether, due to the nature of the work activities and operations carried out by the employee, the PPE clothing provided should be flame retardant.

# General safety measures

## Design and construction

101 The process facility design, construction and the way it is operated should be appropriate to minimising the risk of a spill or release of flammable liquid or vapour and its subsequent ignition. The equipment should be suitable for the liquids being handled, and, where appropriate, should be designed and installed to a suitable British Standard or equivalent. More detailed information is provided in paragraphs 168–195.

## Maintenance and modifications

102 Many incidents involving flammable liquids occur during maintenance and repairs.

103 The likelihood is increased if the work is done by staff or outside contractors who have little knowledge of the hazards associated with flammable liquids. You should only employ experienced contractors. *Managing contractors. A guide for employers* HSG159<sup>24</sup> gives sound practical advice for selecting and managing contractors.

104 The Management Regulations (see Appendix 3) place duties to ensure safe working practices on both the company using the services and the contractor.

105 No maintenance work should be done until:

- the potential hazards of the work have been clearly identified and assessed;
- the precautions needed have been specified in detail;
- the necessary safety equipment has been provided; and
- adequate and clear instruction has been given to all those concerned.

106 In most cases, a PTW system should be used to control maintenance operations in areas where flammable liquids are used or stored. PTWs are formal management documents. They should only be issued by those with clearly assigned authority to do so, and the requirements stated in them must be complied with before the permit is issued and the work covered by it is undertaken. Individual PTWs need to relate to clearly defined individual pieces of work. PTWs should normally include:

- the location and nature of the work intended;
- identification of the hazards, including the residual hazards and those introduced by the work itself;
- the precautions necessary, for example, isolations;
- the personal protective equipment required;
- the proposed time and duration of the work;
- the limits of time for which the permit is valid; and
- the person in direct control of the work.

107 A range of guidance on PTW systems may be found on HSE's website and in HSG250.

108 There are some simple controls you can adopt to reduce the risks of fire and explosion during maintenance hot work. You need to make sure that all flammable or combustible materials are removed from the work area. If it is not reasonably practicable to remove such materials, then you could position suitable screens or partitions to protect the hazardous inventory. Once the work has finished, you need to continue to inspect the area for at least an hour to ensure that there is no smouldering material present. Depending on the nature of the work, further periodic checks may be required for some time after this.

# Cleaning and housekeeping

109 Take care when using flammable liquids for cleaning machinery, equipment or articles, particularly by manual methods. It is preferable to use non-flammable liquids, or liquids with a high flashpoint. Avoid using open tanks or containers of volatile liquids for dipping components etc. Large components should be cleaned in specially designed cleaning stations. Proprietary safety rinse/dip/bench cans are available for dipping smaller articles. These cans are normally fitted with a flame arrester and/or self-closing lids.

110 For manual application of solvents, proprietary ventilated 'wet benches' and other cleaning equipment is available. These use a pump to produce a gentle non-jetting or spraying stream of liquid, with low flow rates and reduce the risk of spillage.

111 Avoid using heated solvents or jetting techniques unless the proposed cleaning temperature and equipment have been shown not to present a risk of fire or explosion with a particular solvent.

112 Keep no more than the minimum amount of flammable liquid in workrooms, usually no more than a half-day's or one shift's supply. Containers of flammable liquid needed for current work should be kept closed when not in use. They should be kept in suitable cabinets or bins in designated areas away from the immediate processing area. Containers which are nominally empty or are not needed for current work should be returned to the appropriate store. For further advice on cabinets, bins and stores see HSG51.

113 Containers at the workplace should:

- be as small as practicable;
- provide resistance to impact damage;
- be able to withstand damage and wear in normal use;
- resist chemical attack by their contents.

114 Proprietary safety containers are recommended (see paragraph 197). Use suitable cradles, trolleys or powered handling equipment for handling drums and other large containers to minimise the risk of spillages and injury to workers. During transport, containers should be securely closed and where necessary secured so that they cannot fall off. Only use authorised routes when transporting the containers.

## Control of spills

115 Housekeeping is fundamental to safety, so maintain a good standard at all times. Deal with spills and leaks promptly. A spill kit should be provided which can be readily accessed from all process areas. The contents of the kit will depend on the properties of the materials being used and the scale and type of spill possible. Typically, for small spills, it should contain inert absorbent material to absorb the spill which can then be scooped up into a metal container for removal. For larger spills, temporary booms or bunds may be needed to contain the spill as far as possible. Additional PPE may also be required.

116 Procedures should be in place for spillage control and removal. Anyone who is expected to deal with a spill should have the appropriate training. The spill procedure should also include actions such as ventilating the area by opening

doors and windows, posting warning notices and whether the area should be evacuated. Additional precautions may be needed to prevent spills entering the drains, unless the drains themselves are fitted with an interceptor system. If electrical equipment such as fans and portable pumps is needed then it should be constructed to a suitable explosion-protection equipment standard. Do not operate electrical switches unless they are similarly protected.

117 When dealing with spillages, take care to prevent workers or their clothing coming into direct contact with the flammable liquid. This would expose them to a serious fire risk. For some spills it may be advisable to call the fire and rescue service as a precaution, or so that they can provide assistance in dealing with the spill. As part of the emergency planning procedures (see paragraphs 124–142), discuss with the fire and rescue service beforehand their involvement in any incident.

118 Place cleaning rags and other items contaminated with flammable liquid in a metal bin, suitably labelled and fitted with a self-closing metal lid. Empty bins at least daily as they present a fire hazard, and the contents may undergo spontaneous combustion, especially if contaminated with paint residues. Special bins are available which allow air to circulate beneath and around them to aid cooling. Contaminated clothing should be changed promptly, even if it appears to have dried, as flammable vapour can remain in clothing for a long time and it can be easily ignited, for example, by standing close to a heater or from smoking materials.

119 Processes should be designed and operated to minimise flammable residues building up on work surfaces, walls etc. Remove any residues regularly, preferably without the use of solvents. Where solvents are necessary, choose those with the least flammable or toxic properties and apply to small sections at a time. Good ventilation is essential during this work, and sources of ignition should be excluded.

## **Disposal**

120 Waste liquids will generally need to be stored and handled according to the same standards as the flammable liquids from which they were derived. They will also be subject to the same legislation, unless their physical properties have been significantly altered by the processing. Dispose of waste liquids safely, taking account of the need to prevent pollution. Never put waste liquid into public drains or watercourses. When in doubt, consult the local waste disposal authority.

121 Do not mix waste materials collected from different processes before disposal unless the various components are known to be compatible, and only after considering the eventual disposal technique to be used. Any drums used for waste materials should be sound and not contain any incompatible residues. If a drum is being used as a collecting station for waste liquids, use a funnel that fits securely into the drum opening to reduce the possibility of spillage. There are funnels with lids and flame arresters to stop any external ignition from flashing back into the drum or to prevent the drum becoming dangerously pressurised if it is engulfed by fire. When not in use, containers of waste liquids should be securely closed to prevent leakage and returned to storage areas or cabinets. Do not add anything to waste liquid containers in storage areas (see paragraphs 50–51), but bring the can or drum out to a designated work area.

122 Recovering waste liquid by distillation or other means may be feasible, particularly where large amounts are involved. Proprietary batch stills with a capacity of a few hundred litres are available, and larger amounts can be sent to a specialist firm for recovery. Seek specialist advice if the solvents to be recovered contain unstable residues such as nitrocellulose.





**Figure 2** Example of system for waste solvent collection

123 Close drums and other containers that have been used to hold flammable liquids but have not been thoroughly cleaned and store them in a safe place before disposal or reuse. The standard of storage should be the same as that for full containers (see HSG51). Provide appropriate labels for containers to be sent off site, whether nominally empty or containing waste materials. The consignor should provide the operator of the vehicle with the necessary information (in writing) about the material to be carried, referring to the relevant carriage legislation (see Appendix 3). Waste flammable liquids sent off site will also be subject to environmental legislation (see paragraph 13).

## Emergency procedures

124 Regulation 8 of DSEAR requires you to make suitable arrangements to deal with accidents, incidents and emergencies involving dangerous substances. Detailed discussion of this requirement is provided in L138.

125 The arrangements are to be taken in addition to the measures already required by regulation 6 of DSEAR to eliminate or reduce risk (by design, and safe operation, instruction and training).

126 Your risk assessment should consider the likelihood, scale and effects on people of foreseeable, unplanned events. The resulting emergency arrangements (including the evacuation of people) should aim to minimise the impact of the event.

127 You should draw up procedures for dealing with the range of foreseeable, unplanned events possible at the workplace, including fire. This should take account of:

- the nature and quantities of the flammable liquids processed or stored;
- the location of the process facility and its design; and
- the people, both on site and off site who may be affected.

128 It is not expected that you will necessarily be able to achieve full mitigation and control of all foreseeable accidents, incidents and emergencies solely by your own means. Rather, this will typically be achieved by a combination of workplace emergency arrangements and those provided by the emergency services.

129 Where foreseeable incidents may affect people or property beyond your site boundary, the emergency services should be consulted when preparing the emergency plans.

130 Formal on-site and off-site emergency plans are required at sites subject to the Control of Major Accident Hazards Regulations (COMAH) (see Appendix 3). Further guidance on this is available in *Emergency planning for major accidents: Control of Major Accident Hazards Regulations 1999 (COMAH) HSG191*.<sup>25</sup>

131 For an effective emergency response, you should have arrangements in place to call the emergency services without unnecessary delay, and for a designated person to meet the emergency services on their arrival to advise them of the situation. Sufficient information should be available on the nature, quantity and location of the flammable liquids and any other substances on site that may have an effect on an incident.

132 When developing your emergency procedures, you should contact the emergency services to advise them of your work activity and provide information as to the nature and quantity of the flammable liquids stored or in process (and any other dangerous substances present) if requested.

133 As well as dealing with any fire, the fire and rescue service is also likely to be able to assist in dealing with other non-fire emergencies, such as released or spilled dangerous substances.

134 Initiating emergency procedures at the earliest stage of an incident can significantly reduce the impact on people and premises. The primary requirement is to ensure people's safety. The requirement to mitigate the effects of the accident, incident or emergency should have regard to this objective and the need not to expose people to any unnecessary risks.

## Leaks and spillages

135 Prompt action to deal with leaks from process plant and equipment can prevent escalation to a larger incident, including fire. You should have arrangements in place to deal with these situations. The supplier's SDS should detail any specific action to be taken for dealing with spillages. You should have SDSs available for all the flammable liquids kept on site.

136 Consider providing non-combustible, absorbent granules or other means for clearing up small spills. Where used, you should have arrangements for their safe disposal.

## Firefighting equipment

137 The nature of the site will dictate the level of precautions needed. With respect to fire, these could vary from using suitable fire extinguishers and/or fire hose reels to tackle a fire in its initial stages, to using monitors or deluge systems to apply cooling water over the container stacks. It is recommended that such provision is discussed with your local fire and rescue authority or the joint fire and rescue board.

138 Whatever firefighting equipment is provided, you should ensure that the people expected to use it are trained and practised in how to do so, without exposing themselves or others to any unnecessary risk from the fire.

139 The presence of a dangerous substance can significantly enhance the speed at which a fire develops and also the amount of smoke and fume evolved. You should take account of this in determining whether the general fire precautions (see paragraphs 143–147) for your workplace are adequate.

## Environment

140 The potential consequences of spillages of flammable liquid, with or without fire, to cause environmental harm should also be considered. Advice on assessing environmental risks can be obtained from the Environment Agency in England; the Scottish Environment Protection Agency (SEPA) in Scotland; or Natural Resources Wales (NRW) in Wales (see paragraph 14).

141 In the event of fire, the potential for fire water run-off can place a major strain on normal drainage facilities and interceptors or special drainage schemes may be necessary, particularly at large installations, to minimise the risk of contaminating local watercourses. In developing appropriate emergency procedures for the workplace, consultation with the appropriate agencies and the local fire authority may be appropriate. Relevant guidance can be found in:

- *Control of fire-water run-off from CIMAH sites to prevent environmental damage* EH70;<sup>26</sup>
- *Containment systems for the prevention of pollution* C736 CIRIA.<sup>27</sup>

142 You should have arrangements for making the situation safe after an incident. For example, safe recovery and clean up of spilt flammable liquids, repairing or decommissioning leaking or unsafe plant, and making safe damaged or unstable buildings.

## General fire precautions

143 'General fire precautions' (the equivalent term 'general fire safety measures' is used in Scotland) are primarily concerned with ensuring people can escape to a place of safety in the event of a fire in the workplace. This includes provision of:

- adequate and appropriate means of detection and giving warning in case of fire;
- adequate means of escape;
- suitable means of fighting fire;
- specifying the action to be taken in the event of fire; and
- appropriate and adequate training of staff in the company's fire safety procedures.

144 You are responsible for carrying out a risk assessment to determine the general fire safety requirements for your workplace. As part of this, you should consider the potential impact of fire involving flammable liquids and adapt the general fire precautions as necessary to make sure they remain sufficient to ensure safety in the event of fire.

145 General fire precautions are subject to separate legislation (see paragraphs 18–20). This includes the requirement for you to ensure they are sufficient for people's safety in the event of a fire involving dangerous substances at the workplace. The requirements of regulations 1–6, 8, 9 and 11 of DSEAR, as they relate to general fire safety, are covered by general fire safety legislation.

146 Detailed consideration of general fire precautions is outside the scope of this guidance. Guidance on how to comply with the law relating to general fire safety requirements and how to carry out a fire risk assessment can be found:

- for England and Wales, in 'Fire safety in the workplace' [www.gov.uk/workplace-fire-safety-your-responsibilities](http://www.gov.uk/workplace-fire-safety-your-responsibilities);
- for Scotland, in 'FireLaw – General guidance' [www.scotland.gov.uk/Topics/Justice/public-safety/Fire-Rescue/FireLaw](http://www.scotland.gov.uk/Topics/Justice/public-safety/Fire-Rescue/FireLaw);
- for England and Wales, 'Fire safety risk assessment: Factories and warehouses' <https://www.gov.uk/government/publications/fire-safety-risk-assessment-factories-and-warehouses>;
- for Scotland, 'Factories & Storage Premises' <http://www.scotland.gov.uk/Topics/Justice/public-safety/Fire-Rescue/FireLaw/FireLaw/SectorSpecificGuidance/FactoriesStorage>;
- for construction sites, *Fire safety in construction* HSG168.<sup>28</sup>

147 Further detailed advice on general fire precautions may be found in BS 9999.<sup>29</sup>

148 General fire legislation applies to the entire workplace. This includes indoor and outdoor work areas. The following guidance will help you determine adequate general fire precautions for use where flammable liquids are handled.

## **Detection and giving warning in case of fire**

149 There should be an effective means of giving warning in case of fire in the process area. It should be audible to all those likely to be affected by the fire. This may vary from small process areas, where a shout of 'fire' might suffice, to larger areas where a klaxon or siren might be required. An assembly point in a safe location should be identified for people evacuating from such areas, where they can be accounted for.

## **Adequate means of escape**

150 The layout of process plant and equipment should be planned and controlled to avoid dead-end situations where possible, ie where escape is only possible in one direction. For any that cannot be avoided, they should be as short as possible. Escape routes should be obvious, with directional escape signs as required; these signs should comply with the Health and Safety (Safety Signs and Signals) Regulations (see Appendix 3). Operational needs should ensure that the gangway widths are adequate, but wherever possible, they should have a minimum width of 1.5 m.

151 At least two exits, well-spaced apart, should normally be provided so that people can turn away from the fire and find an exit. A single exit in a small process area may be sufficient if the distance from any part of the workroom to the exit, measured around the equipment, is not more than 25 m. Exits should open outwards and be immediately openable by people making their escape.

## **Suitable means of fighting fire**

152 An adequate number of fire extinguishers should be provided in the process area. Their primary purpose is to enable an outbreak of fire in its early stages to be tackled, reducing the risk to people and enabling them to make their escape.

153 They need to be positioned in conspicuous locations on the escape routes, such that no one in the work area needs to travel more than 30 m to reach an extinguisher. Unless the location of an extinguisher is otherwise self-evident, you will need to identify its location by appropriate safety signs. Such signs should comply with the Health and Safety (Safety Signs and Signals) Regulations (see Appendix 3).

154 To reduce the risk of corrosion it is sensible to keep extinguishers off the ground and provide protection against the weather, where necessary.

155 Extinguishers should be to a recognised standard such as BS EN 3-7<sup>30</sup> and be suitable for tackling fires involving the flammable liquids present. This is particularly important where alcohol-based flammable liquids are used. The nominal size 9 kg dry powder or 9-litre foam extinguisher is recommended. Such a size of extinguisher combines ease of handling with a reasonable firefighting capability. You should ensure that anybody expected to use a fire extinguisher is properly trained.

## Information and training

156 Adequate training and knowledge of the properties of flammable liquids present on site are essential for their safe handling and the implementation of emergency procedures in the event of an incident.

157 Training is a requirement of the Management Regulations and DSEAR (see Appendix 3 and paragraph 16). Carrying out risk assessments required by these Regulations will identify how much information, training and retraining are needed. Further guidance is available in L138.

158 You should inform all staff on the site about the hazards of flammable liquids, and about the need to exclude sources of ignition and heat from the designated areas. Those responsible for the operation of the process areas also need to receive specific training in how to deal with spillages and leaks, and emergency procedures.

159 Periodic retraining will normally be required. The training should include the following aspects:

- the types of flammable liquid handled, their properties and hazards;
- general procedures for safe handling;
- use of PPE (and RPE);
- housekeeping;
- reporting of faults and incidents, including minor leaks and spills; and
- emergency procedures, including raising the alarm, calling the fire and rescue service and the use of appropriate firefighting equipment.

160 You will need written procedures for controlling the risks from flammable liquids, and these should be used as the basis for training.

### Signage

161 The Health and Safety (Safety Signs and Signals) Regulations (see Appendix 3) and DSEAR regulations 7(3) and 10 (see paragraph 16) require employers to post appropriate safety signs where identified significant risk remains following implementation of the other safety measures. The intention of posting safety signs (including fire safety signs) is to provide warning and instruction to employees of risks to their health and safety. The signs are intended to serve as a reminder to employees of the actions they should take. Employees should therefore receive adequate information and training on these actions and fully understand the meaning of the safety signs and what they require.

162 Your risk assessment will help you determine the nature and extent of safety signs required. Guidance is given in *Health and Safety (Safety Signs and Signals) Regulations 1996. Guidance on Regulations L64*.<sup>31</sup>

163 Safety signs that conform to a recognised standard such as BS EN ISO 7010<sup>32</sup> are acceptable. The signs may be also supplemented with text where you consider this to be appropriate.

164 Typically, unless otherwise made obvious, safety signs are commonly posted at the entrances to the locations where flammable liquids are processed or stored, to warn and remind employees of the precautionary measures to be observed.



**Figure 3** Example of warning and prohibition signs with supplementary text used at entry points to flammable liquid facilities

165 Similarly, unless it is otherwise made obvious (for example, by control of potential ignition sources throughout the site) at the entry points of places that have been classified as hazardous areas (eg gates/doors to process areas) an appropriate sign should be posted to provide warning to those entering those areas that special precautions are required.



**Figure 4** Example of warning sign with supplementary text used at entry points to locations where a potentially explosive atmosphere may exist

# Examples of processes and arrangements

166 This section summarises the safety measures required for:

- the bulk handling of flammable liquids;
- the small-scale dispensing and decanting;
- the spraying and coating purposes.

167 These examples reflect readily achievable good industrial practice. They are intended to help you interpret the safety measures discussed previously (see paragraphs 43–47).

## Bulk handling of flammable liquids

168 Design and operate process areas to minimise risks. Using pipework systems and closed vessels rather than handling liquids in containers and open tanks will restrict the amount of liquid open to the air and reduce the risks from released vapours. Liquids should not be heated above the required working temperature, as the amount of vapour produced increases as the temperature rises.

169 Figure 5 shows a typical process area where flammable liquids are blended in a closed mixing vessel and the product is discharged into containers.

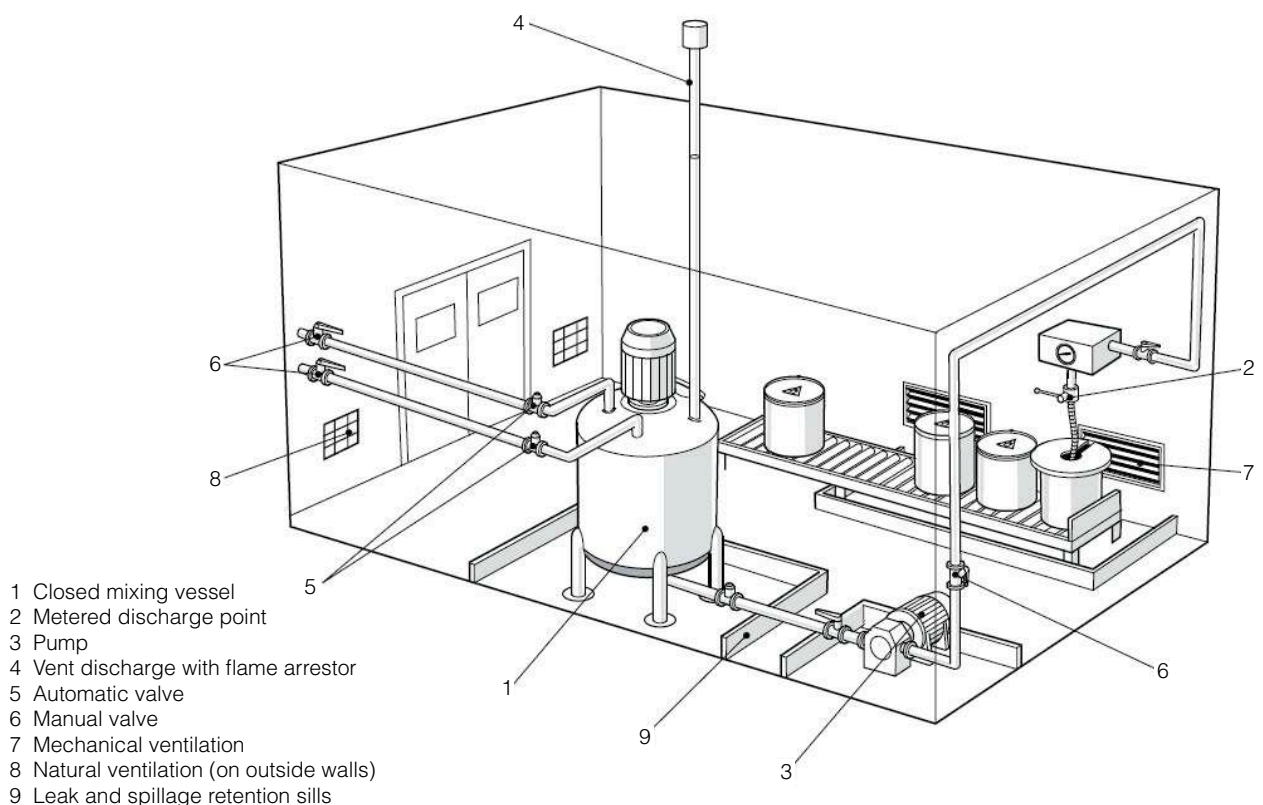

**Figure 5** Diagram illustrating systems in a work area handling flammable liquids



### **Storage**

170 Bulk quantities of flammable liquids are delivered in road tankers. Guidance on the bulk storage of flammable liquids is given in HSG176. This includes advice on tanker loading and offloading facilities.

### **Transfer systems**

171 Flammable liquids should be transferred in enclosed systems, using pipework, pumps and closed vessels. Where liquids are transferred by gas pressure, nitrogen (or another inert gas) or vacuum may be used. Do not use compressed air as it can create an explosive vapour/air mixture inside the transfer vessel.

172 The gas should be controlled to the lowest practicable pressure inside the transfer vessel. Means for rapid isolation of the pressure source and venting of the pipeline or pressure source to a safe place should be provided. It is not advisable to fill into empty containers by gas pressure as it is difficult to control the flow adequately and there is a risk of pressurising the container, causing it to rupture violently. Gravity flow is also difficult to control, except with cans or small drums. Avoid it unless suitable additional safeguards are provided, such as automatic or remotely-operated shut-off valves.

### **Pipework**

173 All parts of piping systems, including valve seals and flange gaskets, should be made from material compatible with the liquids being handled. They should be constructed in accordance with an appropriate standard, for example, the American National Standards Institute Standard B31.3 *Process piping*<sup>33</sup> with Engineering Equipment and Materials Users Association Supplement 153.<sup>34</sup>

174 Plastic or other similar materials are normally only used if there are particular reasons, such as product purity, and if an equivalent standard of construction can be achieved. Plastic pipes, as well as being more vulnerable to fire, may also cause greater electrostatic problems (see paragraphs 72–78). Where possible, welded joints should be used rather than flanges, to minimise the risk of leakage, although piping with a diameter of 50 mm or less may have screwed joints. Joints and connections should be kept to a minimum and should not be positioned where they might leak onto electrical equipment, hot surfaces or other sources of ignition, or where they might prevent the use of an escape route.

### **Pressure**

175 Pressure from thermal expansion of liquids can build up in pipework in which liquids may be trapped, for example, between shut-off valves. Prevent damage to pipework and dangerous releases of flammable liquids as a result of over-pressurisation by assessing the likelihood and consequences of thermal expansion and designing the system to withstand the pressure rises. Alternatively, fit hydrostatic relief valves. Relief valves should normally discharge back to the storage tank, but they may also discharge via a line to a safe place such as a sump or other vessel designed for the recovery or disposal of flammable liquids.

### **Marking**

176 Under the Health and Safety (Safety Signs and Signals) Regulations 1996 (see Appendix 3) the contents of containers and pipes, together with the nature of those contents and any associated hazards, should be clearly identifiable. Marking of pipework is particularly important at filling and discharge points or where there is likely to be confusion with other piping systems. Different filling nozzle designs can be used for different materials to avoid confusion.

### *Locating pipe runs*

177 Pipe runs should preferably be in the open air rather than inside buildings. Pipework should be sized and routed to restrict the contents to a minimum (consistent with pressure-drop requirements). It should be positioned or protected to minimise the risk of impact damage, particularly from vehicles – barriers or bollards may be needed. Pipework supports need to be designed to suit the piping layout and to withstand any anticipated vibration and other stresses.

178 Pipe runs in buildings should normally be in the open and should not pass through hazard areas such as furnace or boiler rooms. They may need protection from other localised hot surfaces or heating systems. Routing pipework through ducts can cause problems in detection and control of leaks, and can allow vapours to travel from one area to another. Ducts should therefore only be used for pipework when there is no safe practical alternative. In this case, the ducts should be constructed to a specified standard of fire-resistance, provided with fire stops at suitable intervals and adequately ventilated. Where ducts or pipes pass through a fire-resisting structure, any gaps between the duct or pipe and the structure should be fire-stopped. Pipework should not be installed in ducts used for heating or ventilation. BS 8313<sup>7</sup> gives further guidance on the design of ducts.

### *Trenches and underground pipework*

179 Pipework may be installed underground, although this presents difficulties with leak prevention, inspection and repair. The pipework should be laid in a shallow concrete or masonry-lined trench provided with load-bearing covers. The design of the trench should prevent water or moisture accumulating around the pipework and allow for inspection of the pipework and in particular, any joints. The design should also allow for any extra loading imposed, for example, by vehicles. Do not use the same trench for piping carrying corrosive or reactive materials such as oxygen or chlorine. The route of the trench should be recorded and permanently marked at the surface.

180 The routing of electric cables in the same trench as pipework should normally be avoided, but where this is not practicable the cables must be prevented from acting as a possible ignition source for any vapours within the trench. Assess the areas inside the trench that present hazards because of pipework joints or from other hazardous areas connected to the trench. Select and install the cables and associated electrical equipment according to BS EN 60079-0 (see paragraph 69) or other equivalent standards. Consider sealing the trench from process areas or other hazardous areas to limit the spread of flammable vapours inside the trench or into safe areas.

181 Underground pipes that must be buried for security or other reasons need protection against corrosion. Buried pipes should be manufactured from stainless steel or galvanised iron covered with a proprietary anti-corrosion paint or tape. Alternatively, they should be provided with secondary containment. All underground joints should be welded, unless welding is inappropriate for corrosion protection or other reasons. In these cases screwed connections are acceptable. Flanged joints are only acceptable if they are situated in a manhole chamber which has been sealed to prevent any leaks of flammable liquid draining into the ground. Buried pipework should be encased in sulphate-resisting concrete. If it is thick enough and bedded properly under the pipe it will prevent damage to the pipeline from any anticipated loads. All buried pipework that cannot be inspected or is not provided with continual leak monitoring will require regular leak testing.

182 Other pipework systems manufactured from glass-reinforced plastic, polypropylene or other plastics and having secondary containment can be used underground as long as they are compatible with the materials being handled.

These systems should be buried in pea shingle or sand in accordance with the manufacturer's instructions. The space between the pipe and its secondary containment should be monitored for leaks. Again, concrete overlay or load-bearing covers will be needed to provide protection from traffic or other additional loading.

### **Flexible hoses**

183 Flexible hoses should only be used where rigid piping is unsuitable, such as at filling connections or where vibration is a problem. They should be adequately supported (for example, by slings or saddles) so that the bend radius is not less than the minimum recommended by the manufacturer.

184 When they are not in use, protect hoses from accidental damage, extremes of temperature and direct sunlight. Inspect them on each day they are used for signs of leaks, wear and mechanical damage, and examine and pressure-test them at least once a year according to the manufacturer's recommendations. It is recommended that you provide blank ends for additional sealing of couplings that are frequently broken and remade.

185 Hoses should be electrically continuous or bridged with an earthing cable to avoid electrostatic charging.

186 Hoses should be made to a standard suitable for the application and should be compatible with the liquids handled. Guidelines on the management of flexible hoses is available in the following publication *Energy Institute: Guidelines for the management of flexible hose assemblies*.<sup>35</sup>

### **Ancillary equipment**

187 Pumps, motors and other equipment forming part of a piping system should be sited in a well-ventilated place, preferably in the open air, with weather protection where necessary. Such ancillary equipment should be situated outside of any bunds for storage tanks. Small leaks from pumps need to be contained by a low sill or drained to a safe place.

188 Where natural ventilation is inadequate, for example in underground pump rooms, mechanical ventilation should be provided (see paragraphs 57–60). Interlocks should be fitted so that the pumps cannot be operated unless the ventilation is working satisfactorily. If the non-operation of a pump could cause a greater hazard than a lack of ventilation in the pump room, a clearly audible alarm should be linked to the ventilation system.

### **Isolation**

189 There should be suitable valves within the pipework system for isolating the supply after use, during maintenance and in the event of an emergency. Consider providing shut-off valves in the following locations:

- at the external supply point;
- externally at the point of entry into the building;
- at the beginning of each branch from a main supply line;
- near each work position or item of plant supplied by the line, where that position is more than 10 m from a valve provided to comply with the last bullet point;
- where pipework passes through an internal wall, partition or floor.

190 All valves should be clearly marked and designed to achieve a rapid shut-down of flow. Valves may be manual or automatic, but automatic valves should be installed to be fail-safe. Where personnel would be exposed to danger when operating valves manually during an emergency, plant should be fitted with remotely operated isolation/shut-off valves (ROSOVs).

### **Filling lines**

191 Filling lines should end as near as possible to the bottom of the vessel, to minimise the free fall of liquid and the generation of static electricity (see paragraph 75). The line should be designed to prevent any siphoning from the filled vessel. Overfill prevention and protection measures should be provided to reduce the likelihood of overfilling the vessels with flammable liquids. These measures will depend on the process and the plant design. They include:

- a level detector linked to an alarm, pump or valve;
- a pre-set meter;
- a fixed volume batch tank;
- an overflow system.

192 Where a high-level alarm system is fitted, it should be triggered at one level to alert the operator to shut off the valve or pump, and at a second level to shut it off automatically if the operator takes no action. Before installing automatic shut-off valves, assess whether shock loading within the supply line could result in any hazards.

### **Vent pipes**

193 Vent pipes should normally be provided on process plant. These will prevent flammable and toxic vapours released during filling and processing from accumulating in work areas and direct them away from plant operators and possible ignition sources. Vent pipes should be big enough to prevent over-pressurisation of the plant from material additions and other process operations. The vent pipes may also have to be designed to take into account any exothermic reactions, but this requirement is outside the scope of this book. (Guidance may be found in *Designing and operating safe chemical reaction processes* HSG143.)<sup>36</sup> For small open process vessels where materials are added manually, local exhaust ventilation may be more suitable than fixed vent pipes.

194 Vent pipes should terminate outside buildings, well away from possible ignition sources, so that any vapours can be rapidly dispersed and not re-enter the source building or other buildings. Ideally, vent pipes should discharge vertically upwards, but horizontal discharge may be acceptable. The vent pipe should normally finish at least 5 m above ground level; 3 m from building openings, boundaries and sources of ignition; and away from building eaves and other obstructions. These distances may, however, vary according to the site layout. There may also be environmental restrictions on the positioning of vents and exhaust ducts.

195 On vessels containing liquids with a flashpoint of 23 °C or below, or for other liquids processed above their flashpoint, the vent outlet should be fitted with a flame arrester, unless the liquid is liable to polymerise or otherwise block the arrester. Flame arresters should be designed to the appropriate standard as described in BS EN ISO 16852. Flame arresters should be maintained to prevent blockage by paint, rust or other materials.

### Intermediate bulk containers

196 Intermediate bulk containers (IBCs) are widely used for the supply of flammable liquids. Guidance may be found in the joint CBA/SIA publication *Guidance for the storage of liquids in intermediate bulk containers*.<sup>37</sup>

### Small-scale dispensing and decanting

197 Dispensing and decanting should be carried out in a way which reduces spills and dangerous releases of flammable vapours. The need for these operations should be assessed and, where possible, the risks should be minimised by the use of enclosed transfer systems (see paragraph 171). If an enclosed system cannot be used, the containers should be designed to minimise spillage, release of vapour and the effects of fire. Small safety containers are available (see Figure 6 and Figure 7) which incorporate the following features:

- metal or heavy-duty plastic construction;
- pouring and/or filling apertures sealed with self-closing spring-loaded caps;
- pouring and/or filling apertures fitted with flame arresters;
- hoses or other aids when dispensing into small openings;
- carrying handles for containers with a capacity greater than approximately 2.5 litres.

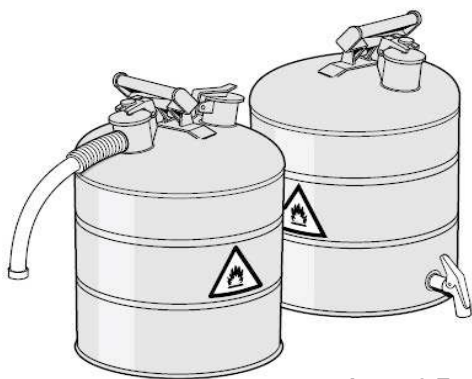

**Figure 6** Examples of safety containers



**Figure 7** Examples of special purpose containers for flammable liquids

198 Containers should be able to resist wear and tear in normal use and corrosion by the specific liquid being used. They should be strong enough to withstand being dropped. Plastic containers should be compatible with the fluid that they are intended to contain. They should incorporate anti-static features so that any metal components in the transfer system, such as flame arresters or funnels, cannot build up incendive electrostatic charges. The use of containers approved by a recognised testing and approval organisation is recommended.

199 Open-topped cans and buckets should not be used for handling or storing flammable liquids as they increase the risk of spillage and the release of vapours. Drums should be provided with secure closures that can withstand the expected

handling conditions without leaking. Drums with large removable ends are not normally suitable for flammable liquids. Open-ended drums or receptacles with fitting lids or covers may be adequate for viscous liquids such as paints, provided the container is not easily tipped over. Drums and cans should always be opened so that they can easily be closed again, not by punching holes in the cap or in the drum wall.

200 Decanting or transfer from one container to another should normally be carried out away from the area where the liquid is stored, and preferably in the open air or in a separate, well-ventilated room, so that any spillage and possible fire cannot involve the stored materials. When pouring manually from or into small containers, use a funnel to minimise spillage. Spill trays, drip cans and other means to contain spillages should be provided where decanting or dispensing is carried out, and containers should be bonded together and earthed (see paragraph 73). Also consider providing flame arresters in the container vent to reduce evaporation and to prevent an explosion inside the container in case of an external fire.

201 Where flammable liquids are routinely dispensed from 210 litre drums the following alternative methods are recommended.

#### **Using drum safety taps in conjunction with safety vents**

202 Drum taps should be made of non-combustible material and be self-closing. Safety vents prevent excess pressure or vacuum building up inside the drum and stop any ignition source from flashing back into the drum (see Figure 8). A safety vent also reduces the likelihood of a drum exploding if it is engulfed by fire. When dispensing into containers with small apertures, use a funnel or taps fitted with small-diameter hoses to minimise spillage.

**Figure 8** System for decanting from 210 litre drum using safety tap



#### **Using small portable drum pumps**

203 Pumps ought to fit closely into the drum to minimise release of vapours (see Figure 9), but they also need to be able to relieve pressure in the event of a fire. Flexible hoses need to be electrically conducting. If an electric pump is used, the electrical equipment should be constructed to a suitable explosion-protection standard (see paragraph 69).

**Figure 9** System for decanting from 210 litre drum using hand pump



204 All containers should be labelled according to their purpose, so that people who use them or come into contact with them are aware of their contents and the hazards associated with them. Flammable liquids that are being handled in their original containers should be suitably labelled in accordance with CLP (see Appendix 3).

205 Where liquids are transferred into secondary containers for in-house use, the containers should be labelled to indicate their contents and the possible hazards. For flammable liquids the fire hazard may be shown by labelling conforming to BS EN ISO 7010, BS 5499-10 or by a red diamond showing the fire logo and the words 'flammable liquid'.

206 Containers filled from bulk storage tanks or vessels may be labelled in accordance with the requirements for those tanks or vessels. Containers that are nominally empty may also be potentially dangerous and should be handled, stored and labelled as if they were full.

207 The need for additional fire precautions should also be taken into account in assessing the safety of a particular dispensing operation.

### **Spraying and coating processes**

208 Flammable liquids are often used in spraying and coating processes. Much of the advice given in the previous sections is relevant. The main difference is that in spraying and coating processes, flammable liquids are deliberately released within the work area. Consequently, the use of low flashpoint paints and coating should be avoided wherever practicable. Coatings which are water-based or have a higher flashpoint may provide suitable alternatives.

209 The following paragraphs give advice on the control measures to prevent fire and explosion. However, the risks to health or the environment should also be considered. Additional measures may be required to comply with environmental legislation (see paragraph 13) and the Control of Substances Hazardous to Health Regulations (COSHH) (see Appendix 3).

#### **Fire precautions**

210 Suitable portable firefighting equipment should be provided for all spraying areas. The type and location of all such equipment should be agreed with the fire and rescue authority. For further information see paragraphs 128–141.

211 In large spraying areas, or large enclosed spray booths, consider providing fixed sprinkler systems which can be operated either automatically or manually using a panic-button system. Automatic fire warning systems and interlocks with the ventilation may also be advisable particularly for automatic spray booths. It is advisable to discuss the installation of a sprinkler system with the fire and rescue authority and with the fire insurance company. The fire and rescue authority will also need to discuss their requirements for firefighting such as water supplies and access for appliances.

#### **Spray booths**

212 Spraying and coating operations should be carried out in an enclosure such as a cabinet or booth designed for the purpose. There are many different designs depending on the type and size of articles to be sprayed, the method of ventilation (side or down-draught air flow) and the method of removing

particulates from the exhaust air flow (water wash, baffles or dry filters). Further information on spray booths is available in BS EN 12215.<sup>38</sup> Specific advice on paint mixing and spraying systems for motor body repair and re-finishing is contained in *Health and safety in motor vehicle repair and associated industries* HSG261.<sup>39</sup> Advice on extraction and ventilation may be found in guidance document HSG258.

213 The cabinet or booth should be of at least 30 minutes' fire-resisting construction. Similarly, any ductwork should be at least 30 minutes' fire resisting. It should be as short as practicable and have no sharp bends, as this tends to decrease the airflow and allow the deposition of residues. Locating the spray booth near an external wall may reduce the length of duct required to discharge the exhaust air outside the building. Access points for inspection and cleaning inside the ducts may be needed. Dampers should not be fitted inside exhaust ducts unless they are essential for balancing the ventilation system.

214 Ventilation should be provided to remove vapours released from the process and to keep the vapour concentration below 25% of the lower explosion limit (LEL). In most cases, mechanical ventilation will be required (see paragraphs 57–56). Failure of the ventilation system should trigger an alarm and if necessary shut down the spraying/coating process. Materials that may present health risks will require a higher standard of ventilation and additional precautions.

215 Electric motors for fans should not be situated in the path of flammable vapours. This may be achieved using bifurcated, centrifugal-type or belt-driven axial fans. Motors, even if they are of flameproof construction, should not be sited within the ducts. As a relatively high volume of air will be exhausted, the room containing the spray process should be provided with adequately sized fresh air inlets.

216 Electrical equipment, such as compressor motors, switches and electrostatic power packs, should be excluded from the booth, where possible. Any electrical equipment that has to be inside the booth should be designed and constructed for use in zone 1 or zone 2 (see L138, regulation 7 and Schedules 2–4) according to the hazardous area classification. It should be located to prevent it being covered with flammable residues.

### **Drying and curing ovens**

217 Flammable vapours are also released during the drying process and may present a serious fire hazard. The drying conditions will depend on the type of coating; some will dry at room temperature, others may need curing or baking at higher temperatures. For drying at room temperature, the spray booth or a designated drying or 'flash-off' area may be used. Ventilation should be provided to prevent the build-up of flammable vapours.

218 Ovens are used for drying or curing at higher temperatures. They may be separate or combined with a spray booth (combi-booth). They should be ventilated to prevent the build-up of flammable vapours. Some are designed to recirculate a proportion of the warm (solvent-laden) air. The dampers should be positioned to maintain an adequate exhaust flow rate. The vapour concentration may be monitored with gas detectors which can trigger an alarm, emergency ventilation and shutdown, if the concentration exceeds a specified level.

219 Generally, explosion relief should be fitted unless the oven or combi-booth is protected by a gas detection and alarm system. Explosion relief should be properly maintained; it should not be covered, obstructed or nailed down. It should vent to a safe place.



220 No one should enter an oven or booth during the drying or curing cycle. In some circumstances, it may be necessary to lock doors or interlock them with the heating system. The supplier's instructions should be followed.

### ***Spraying in a workroom***

221 Sometimes it is impracticable to use a spraybooth to contain the spraying operation, for example when spraying large items of steelwork or aircraft. In this case, spraying may be carried out in a workroom provided adequate health and safety precautions are taken. If the room to be used for spraying is within a building, there should be 30 minutes' fire separation between the spray room and the rest of the building. If the spray area is part of a larger room (for example a hangar), dividing the room with fire-resistant curtains will define the spraying area and will provide some fire protection.

222 Before spraying, all potential sources of ignition should be removed. Unprotected electrical equipment should be removed or isolated. If there has to be any electrical equipment within the spray room, a hazardous area classification should be carried out to decide the level of protection required.

223 Ventilation should be provided to ensure that the concentration of flammable vapours remains below 25% LEL both during the spraying operation and the subsequent drying period. Monitoring using an explosimeter may be necessary. The use of a spray system that reduces the quantity of solvent used, and the overspray produced, is recommended. Care should be taken to ensure that the ventilation is effective at low level and anywhere vapours could accumulate. Further control measures may be needed to ensure that the exposure to harmful substances is prevented as required by COSHH (see Appendix 3).

224 On occasion, spraying outdoors or in the open air may be unavoidable such as applying coatings to large structures. The precautions are similar to those for workrooms. All potential sources of ignition should be removed before spraying. The 'natural' ventilation should be checked to ensure it is adequate to disperse vapours. Additional mechanical ventilation may be necessary if the spray area is in a 'sheltered' location or surrounded by walls and other structures. Spraying should not be carried out near building openings or near pits, trenches, basements etc where flammable vapours could accumulate. Again, the use of a spray system that reduces the quantity of solvent used and the overspray produced is recommended.

### ***Spraying in confined spaces***

225 Spraying is often used to apply coatings to the inside of storage tanks, ships' holds and other enclosed rooms and spaces. The dangers associated with spraying in confined spaces cannot be too strongly emphasised. In an unventilated enclosure, a harmful vapour concentration may be formed within a few seconds of starting spraying, and a flammable atmosphere within a few minutes. Therefore, those spraying in confined spaces should have adequate safety training and be aware of the hazards involved. A formal written entry permit or permit-to-work is always required for entry into confined spaces. Advice on the duties, precautions and safe systems of work when working inside confined spaces is contained in *Safe work in confined spaces L101*.<sup>40</sup>

226 Mechanical exhaust ventilation should be provided to ensure that the concentration in all parts of the confined space is at a safe level. The concentration of flammable vapour should never exceed 25% LEL and it should be maintained preferably below 10% LEL (10% LEL is the safe working limit as set out in Energy Institute *Model Code of Safe Practice Part 16: Tank Cleaning Safety Code*).<sup>41</sup>

Vapours from spraying are likely to accumulate at floor level so you should provide extraction at this level. The discharge point should be situated in a safe place away from any buildings, work area or source of ignition. You should provide a correctly designed ventilation system even when paint or other highly flammable material is applied by a brush or roller.

227 Any increase in the flammable vapour concentration above the specified limit (preferably 10% LEL) should be detected immediately. If operators are wearing breathing apparatus and protective clothing, they may not be aware of increasing levels of vapour. The instrument normally used is a gas detector or explosimeter preferably with an alarm function. Any alarm should be clearly audible to the people in the confined space. Continuous monitoring is recommended although periodic check measurements may be sufficient, once the effectiveness of the ventilation system has been confirmed. Reassessment of the ventilation may be necessary if there are changes in spraying conditions such as if the number of sprayers is increased or more volatile coating is used. Any person using an explosimeter should have received thorough training in the use of the instrument and in the interpretation of the results.

228 Sources of ignition inside the confined space should be prohibited and any lighting should be protected to a standard suitable for zone 1. Any unprotected equipment used (such as fan motors, compressors, switches and alarms) must be sited in safe areas outside the confined space where they cannot be exposed to flammable concentrations of vapour. You should maintain the ventilation within the confined space until the coating is dry and there is no further risk of a flammable atmosphere. Any accumulation of flammable vapours could be ignited inside the confined space by hot work on the outside.

# Appendix 1 Physical barriers of fire-resisting construction

See the following sections from *Dangerous substances and explosives atmospheres. Dangerous Substances and Explosive Atmospheres Regulations 2002. Approved Code of Practice and guidance L138* (Second edition 2013) for information on design and performance requirements of physical barriers of fire-resisting construction:

- paragraphs 266–279;
- Appendix 4 Fire resistance;
- Appendix 5 Fire reaction.

## Appendix 2 Mechanical exhaust ventilation (MEV)

- 1 The following requirements apply where mechanical exhaust ventilation (MEV) systems are to be installed in rooms or buildings used for storing and using flammable liquids in containers.
- 2 Where MEV is provided it needs to operate continuously. Failure or critical diminution of the exhaust airflow should be detected by an airflow monitoring device installed in the ductwork (such as a flow switch or differential pressure switch) and linked to an alarm.
- 3 The exhausted air should discharge to a safe place in the open air. Where ductwork is required to achieve this, it should be fire-resisting (see Appendix 1) and arranged so that vapours cannot condense and collect at low points within it. In most cases it should be adequate if the MEV exhausts:
  - at least 3 m above ground level;
  - at least 3 m from building openings, boundaries, sources of ignition; and
  - away from building eaves and other obstructions.
- 4 Requirements for positioning exhausts from ventilation systems may be found in Process Guidance Notes issued by Defra.
- 5 The MEV should be included in the hazardous area classification assessment for the premises (see L138, regulation 7 and Schedules 2–4) the circumstances of intended use, it is normally appropriate to consider the internal volumes of the MEV system, including ductwork to be zone 2.
- 6 Where the MEV is provided by a fan assembly in an external wall leading directly to outside, it should be ATEX certified for use in the zone determined. This includes the fan impellers, casing and couplings. A relevant design standard for fans on MEV systems in relation to hazardous explosive atmospheres is BS EN 14986.<sup>42</sup>
- 7 Where the MEV incorporates ductwork, the fan electric motor should not be installed within the ductwork. Instead, a centrifugal or bifurcated fan should be used. As the fan impeller necessarily has to be in the path of the flammable liquid vapours being extracted, it does present a potential ignition source from static discharge, frictional sparking or rubbing. To prevent this, the fan impeller, its casing and couplings should be ATEX certified as suitable for use in the zone determined for the ductwork.
- 8 Further guidance on MEV is given in L138 and in the following HSE guidance:
  - *Clearing the air. A simple guide to buying and using local exhaust ventilation (LEV)* INDG408;<sup>43</sup>
  - *Time to clear the air! A workers' pocket guide to local exhaust ventilation (LEV)* INDG409;<sup>44</sup>
  - *Controlling airborne contaminants at work: A guide to local exhaust ventilation (LEV)* HSG258;
  - local exhaust ventilation (LEV) workplace dust and fume extraction HSE webpages at [www.hse.gov.uk/lev](http://www.hse.gov.uk/lev).

# Appendix 3 Other relevant health and safety legislation

## Management of Health and Safety at Work Regulations 1999 (the Management Regulations)

- 1 The Management Regulations require employers and the self-employed to assess the general risks to health and safety arising from their work activity and identify the preventive and protective measures that need to be taken to control the identified risks.
- 2 The more specific provisions of DSEAR (see paragraph 16) will only apply where dangerous substances are present or used. For example, an assessment of the risks from dangerous substances and arrangements for emergencies carried out under DSEAR will not need to be repeated under the Management Regulations, and may be incorporated into the more general 'management' assessment as a subset.
- 3 There are legal requirements, in other regulations, to consult employees. It can be helpful to involve employees or their representatives when carrying out risk assessments.

## Control of Substances Hazardous to Health Regulations 2002 (COSHH)

- 4 Flammable liquids are dangerous (to safety) in terms of DSEAR, but they are also likely to present a health risk for which COSHH will apply. The supplier's SDS should provide information on this, where the employer will have duties to control the health and safety risks under both COSHH and DSEAR. By considering the requirements together, development and implementation of a single set of safety measures to satisfy the requirements of both sets of regulations should be possible.

## CLP and CHIP

- 5 From 1 June 2015, chemical suppliers must comply only with the CLP Regulation.
- 6 European Regulation (EC) No 1272/2008 on Classification, Labelling and Packaging of Substances and Mixtures (known as the CLP Regulation or CLP) has repealed both the Dangerous Substances Directive (67/548/EEC) and the Dangerous Preparations Directive (99/45/EC) and became the primary legislation in this area.
- 7 The CLP Regulation adopts across the European Union the United Nations' Globally Harmonised System on chemical classification and labelling (GHS). The CLP Regulation is directly acting on all European Union member states. This means that, unlike with directives, no national transposition is necessary and the need for the Chemicals (Hazard Information and Packaging for Supply) Regulations 2009 (CHIP Regulations) falls away. However, regulation 12 of CHIP requires that the person who is responsible for first supplying a dangerous preparation has to keep a

record of the information for at least three years after it is last supplied; this provision of CHIP will remain until June 2018, after which CHIP is fully revoked.

8 Preparations classified, labelled and packaged in accordance with CHIP and placed on the market before 1 June 2015, do not need to be relabelled and repackaged in accordance with the CLP Regulation until 1 June 2017. Product hazard labels must only show the details of one regime – ‘mixed’ labels are not permitted.

### **Provision and Use of Work Equipment Regulations 1998 (PUWER)**

9 These Regulations ensure that safe work equipment is provided, maintained in good working order and is safely used. Regulation 12 of PUWER is particularly relevant to equipment associated with flammable liquids, as it requires employers to ensure that people using work equipment are not exposed to hazards arising from:

- equipment catching fire or overheating;
- the unintended or premature discharge of any liquid or vapour;
- the unintended or premature explosion of the work equipment or any substance used or stored in it.

### **Equipment and Protective Systems Intended for Use in Potentially Explosive Atmospheres Regulations 1996 (EPS)**

10 EPS applies to the supply of both electrical and mechanical equipment and protective systems intended for use in potentially explosive atmospheres. New equipment etc supplied for use in places where an explosive atmosphere may occur must meet the requirements of EPS whatever its source.

### **Planning (Hazardous Substance) Regulations 1992**

11 Sites, manufacturing or processing flammable liquids may be required to apply for permission under the Planning (Hazardous Substance) Regulations 1992 in England and Wales or the Town and Country Planning (Hazardous Substances) (Scotland) Regulations 1993. Application is usually to the local planning authority with HSE being a statutory consultee in the application process.

### **Dangerous Substances (Notification and Marking of Sites) Regulations 1990 (NAMOS)**

12 NAMOS aims to ensure that firefighters arriving at an incident are warned of the presence of dangerous substances. Advice on NAMOS is available in *Notification and marking of sites* HSR29.<sup>45</sup>

### **Control of Major Accident Hazards Regulations 1999 (COMAH)**

13 COMAH aims to prevent and mitigate the effects of those major accidents involving dangerous substances which can cause serious damage/harm to people and/or the environment. The COMAH Regulations treat risks to the environment as seriously as those to people. For further guidance on COMAH see the HSE website [www.hse.gov.uk/comah/guidance.htm](http://www.hse.gov.uk/comah/guidance.htm).

## **Consulting employees and safety representatives**

14 Employers must consult safety representatives appointed by recognised trades unions under the Safety Representatives and Safety Committees Regulations 1977. Employees who are not covered by such representatives must be consulted either directly or indirectly, through elected representatives of employee safety under the Health and Safety (Consultation with Employees) Regulations 1996.

15 Proper consultation with those who know precisely how the work is done, including short cuts, is crucial and helps to build a culture of awareness of health and safety. It can benefit the business by making it more efficient and reducing losses and damage.

## **Electricity at Work Regulations 1989**

16 These Regulations impose health and safety duties for the safe use of electricity at work. They require electrical installations and equipment to be properly constructed, maintained and fit for the purpose and environment in which they are to be used. In particular, they require electrical equipment which is exposed (or reasonably expected to be exposed) to a flammable or explosive substances, including flammable vapours or gases, to be constructed or protected so as to prevent danger. Advice is available in *The Electricity at Work Regulations 1989. Guidance on Regulations* HSR25.<sup>46</sup>

## **Carriage of Dangerous Goods and Use of Transportable Pressure Equipment Regulations 2009 (CDG)**

17 Carrying goods by road or rail involves the risk of traffic accidents. If the goods are dangerous, there is also the risk of incidents, such as spillage, leading to hazards such as fire, explosion, chemical burn or environmental damage. The CDG Regulations implement ADR (the European Agreement concerning the International Carriage of Dangerous Goods by Road) with a number of exceptions which can be found in *Carriage of dangerous goods: Approved derogations and transitional provisions* document at <https://www.gov.uk/government/publications/the-carriage-of-dangerous-goods-approved-derogations-and-transitional-provisions>.

18 Flammable liquids as defined in this guidance are within scope of CDG, the aim of which is to reduce the risks involved in transporting such substances by requiring them to be correctly classified, packaged and labelled. The Regulations specify that dangerous goods should be carried in suitable receptacles which will not leak under normal handling. These should bear appropriate warning labels giving information on the nature of the hazards.

## **Health and Safety (Safety Signs and Signals) Regulations 1996**

19 These Regulations implement a European Council Directive on minimum requirements for provision of workplace safety signs. The Directive standardises use throughout EU member states to ensure particular signs provide the same message wherever witnessed.

### **Health and Safety Enforcing Authority Regulations 1998**

20 These Regulations allocate to local authorities the responsibility for enforcing the HSW Act and its relevant statutory provisions, subject to specific exceptions, in all premises where the main activity is listed in Schedule 1 to the Regulations.

### **Food and Environment Protection Act 1985 (FEPA)**

21 All pesticides are subject to FEPA, this guidance covers safety aspects of the flammability hazards of those pesticides which are also flammable liquids.

22 Further guidance on the safe storage of pesticides may be found in *Guidance on storing pesticides for farmers and other professional users* AIS16.<sup>47</sup>

### **Petroleum (Consolidation) Regulations 2014**

23 These Regulations apply to workplaces that store petrol and dispense it through manual or electrical pumping from a storage tank directly into the tank of a vehicle with an internal combustion engine. These Regulations also apply to storage of petrol at non-workplace premises, eg private homes, clubs, associations etc.



# References

- 1 *Storage of flammable liquids in containers* HSG51 (Third edition) HSE Books 2015 ISBN 978 0 7176 6608 9 [www.hse.gov.uk/pubns/books/hsg51.htm](http://www.hse.gov.uk/pubns/books/hsg51.htm)
- 2 *Storage of flammable liquids in tanks* HSG176 (Second edition) HSE Books 2015 ISBN 978 0 7176 6607 2 [www.hse.gov.uk/pubns/books/hsg176.htm](http://www.hse.gov.uk/pubns/books/hsg176.htm)
- 3 *Dangerous substances and explosive atmospheres: Dangerous Substances and Explosive Atmospheres Regulations 2002. Approved Code of Practice and guidance* L138 (Second edition) HSE Books 2013 ISBN 978 0 7176 6616 4 [www.hse.gov.uk/pubns/books/l138.htm](http://www.hse.gov.uk/pubns/books/l138.htm)
- 4 *EH40/2005 Workplace exposure limits: Containing the list of workplace exposure limits for use with the Control of Substances Hazardous to Health Regulations (as amended)* Environmental Hygiene Guidance Note EH40 (Second edition) HSE Books 2011 ISBN 978 0 7176 6446 7 [www.hse.gov.uk/pubns/books/eh40.htm](http://www.hse.gov.uk/pubns/books/eh40.htm)
- 5 *Controlling airborne contaminants at work: A guide to local exhaust ventilation (LEV)* HSG258 (Second edition) HSE Books 2011 ISBN 978 0 7176 6415 3 [www.hse.gov.uk/pubns/books/hsg258.htm](http://www.hse.gov.uk/pubns/books/hsg258.htm)
- 6 Environmental Protection Act 1990. Part 1 Integrated pollution control and air pollution control by local authorities. Defra Solvent Sector Process Guidance Notes and Petroleum and Powder Coatings Sector Process Guidance Notes [www.defra.gov.uk/industrial-emissions/las-regulations/guidance/](http://www.defra.gov.uk/industrial-emissions/las-regulations/guidance/)
- 7 BS 8313:1997 *Code of practice for accommodation of building services in ducts* British Standards Institution
- 8 BS EN 1127-1:2011 *Explosive atmospheres. Explosion prevention and protection. Basic concepts and methodology* British Standards Institution
- 9 BS EN 60079-10-1:2009 *Explosive atmospheres. Classification of areas. Explosive gas atmospheres* British Standards Institution
- 10 *Model Code of Safe Practice Part 15: Area Classification Code for Installations Handling Flammable Fluids* (Third edition) Energy Institute 2005 [www.energypublishing.org](http://www.energypublishing.org)
- 11 BS EN 13463-1:2009 *Non-electrical equipment for use in potentially explosive atmospheres. Basic method and requirements* British Standards Institution
- 12 BS EN 60079-14:2008 *Explosive atmospheres. Electrical installations design, selection and erection* British Standards Institution
- 13 BS EN 60079-0:2012+A11:2013 *Explosive atmospheres. Equipment. General requirements* British Standards Institution
- 14 BS EN ISO 16852:2010 *Flame arresters. Performance requirements, test methods and limits for use* British Standards Institution
- 15 PD IEC/TS 60079-32-1:2013 *Explosive atmospheres. Electrostatic hazards, guidance* British Standards Institution

- 16 BS 7430:2011 *Code of practice for protective earthing of electrical installations* British Standards Institution
- 17 BS 5958-1:1991 *Code of practice for control of undesirable static electricity* Part 1:1991 *General considerations* Part 2:1991 *Recommendations for particular industrial situations* British Standards Institution
- 18 BS EN 1755:2000+A2:2013 *Safety of industrial trucks. Operation in potentially explosive atmospheres. Use in flammable gas, vapour, mist and dust* British Standards Institution
- 19 BS EN 60079-30-1:2007 *Explosive atmospheres. Electrical resistance trace heating. General and testing requirements* British Standards Institution
- 20 *The cleaning and gas freeing of tanks containing flammable residues* Chemical Safety Guidance Note CS15 HSE Books 1985  
[www.hse.gov.uk/pubns/books/cs15.htm](http://www.hse.gov.uk/pubns/books/cs15.htm)
- 21 *Guidance on permit-to-work systems: A guide for the petroleum, chemical and allied industries* HSG250 HSE Books 2005 ISBN 978 0 7176 2943 5  
[www.hse.gov.uk/pubns/books/hsg250.htm](http://www.hse.gov.uk/pubns/books/hsg250.htm)
- 22 BS 5499-10:2006 *Safety signs, including fire safety signs. Code of practice for the use of safety signs, including fire safety signs* British Standards Institution
- 23 *Chemical warehousing: The storage of packaged dangerous substances* HSG71 (Fourth edition) HSE Books 2009 ISBN 978 0 7176 6237 1  
[www.hse.gov.uk/pubns/books/hsg71.htm](http://www.hse.gov.uk/pubns/books/hsg71.htm)
- 24 *Managing contractors: A guide for employers* HSG159 (Second edition) HSE Books 2011 ISBN 978 0 7176 6436 8 [www.hse.gov.uk/pubns/books/hsg159.htm](http://www.hse.gov.uk/pubns/books/hsg159.htm)
- 25 *Emergency planning for major accidents: Control of Major Accident Hazards Regulations* 1999 HSG191 HSE Books 1999 ISBN 978 0 7176 1695 4  
[www.hse.gov.uk/pubns/books/hsg191.htm](http://www.hse.gov.uk/pubns/books/hsg191.htm)
- 26 *The control of fire-water run-off from CIMAH sites to prevent environmental damage* Environmental Hygiene Guidance Note EH70 HSE Books 1995  
[www.hse.gov.uk/pubns/books/eh70.htm](http://www.hse.gov.uk/pubns/books/eh70.htm)
- 27 *Containment systems for the prevention of pollution: Secondary, tertiary and other measures for industrial and commercial premises* C736 CIRIA [www.ciria.org](http://www.ciria.org)
- 28 *Fire safety in construction: Guidance for clients, designers and those managing and carrying out construction work involving significant fire risks* HSG168 (Second edition) HSE Books 2010 ISBN 978 0 7176 6345 3  
[www.hse.gov.uk/pubns/books/hsg168.htm](http://www.hse.gov.uk/pubns/books/hsg168.htm)
- 29 BS 9999:2008 *Code of practice for fire safety in the design, management and use of buildings* British Standards Institution
- 30 BS EN 3-7:2004+A1:2007 *Portable fire extinguishers. Characteristics, performance requirements and test methods* British Standards Institution
- 31 *Safety signs and signals. The Health and Safety (Safety Signs and Signals) Regulations 1996. Guidance on Regulations* L64 (Third edition) HSE Books 2015 ISBN 978 0 7176 6598 3 [www.hse.gov.uk/pubns/books/l64.htm](http://www.hse.gov.uk/pubns/books/l64.htm)

- 32 BS EN ISO 7010:2012 *Graphical symbols. Safety colours and safety signs. Registered safety signs* British Standards Institution
- 33 Standard B31.3-2012 *Process Piping* American National Standards Institute <http://webstore.ansi.org/default.aspx>
- 34 153/96 *EEMUA Supplement to ASME B31.3 Edition: Process Piping* Engineering Equipment and Materials Users Association [www.eemua.co.uk](http://www.eemua.co.uk)
- 35 *Guidelines for the management of flexible hose assemblies* (Second edition) 2011 Energy Institute ISBN 9780852935880
- 36 *Designing and operating safe chemical reaction processes* HSG143 HSE Books 2000 ISBN 978 0 7176 1051 8 [www.hse.gov.uk/pubns/books/hsg143.htm](http://www.hse.gov.uk/pubns/books/hsg143.htm)
- 37 *Guidance for the storage of liquids in intermediate bulk containers* Chemical Business Association and Solvents Industry Association 2008 [www.chemical.org.uk/regulatoryissues/healthandsafety/jointcbasiastorageguidance.aspx](http://www.chemical.org.uk/regulatoryissues/healthandsafety/jointcbasiastorageguidance.aspx)
- 38 BS EN 12215:2004+A1:2009 *Coating plants. Spray booths for application of organic liquid coating materials. Safety requirements* British Standards Institution
- 39 *Health and safety in motor vehicle repair and associated industries* HSG261 HSE Books 2009 ISBN 978 0 7176 6308 8 [www.hse.gov.uk/pubns/books/hsg261.htm](http://www.hse.gov.uk/pubns/books/hsg261.htm)
- 40 *Safe work in confined spaces. Confined Spaces Regulations 1997. Approved Code of Practice, Regulations and guidance* L101 (Second edition) HSE Books 2009 ISBN 978 0 7176 6233 3 [www.hse.gov.uk/pubns/books/l101.htm](http://www.hse.gov.uk/pubns/books/l101.htm)
- 41 *Model Code of Safe Practice Part 16: Tank Cleaning Safety Code* (Third edition) Energy Institute 2006 [www.energypublishing.org](http://www.energypublishing.org)
- 42 BS EN 14986:2007 *Design of fans working in potentially explosive atmospheres* British Standards Institution
- 43 *Clearing the air: A simple guide to buying and using local exhaust ventilation (LEV)* Leaflet INDG408 HSE Books 2008 [www.hse.gov.uk/pubns/indg408.htm](http://www.hse.gov.uk/pubns/indg408.htm)
- 44 *Time to clear the air! A workers' pocket guide to local exhaust ventilation (LEV)* INDG409 HSE Books 2008 [www.hse.gov.uk/pubns/indg409.htm](http://www.hse.gov.uk/pubns/indg409.htm)
- 45 *Notification and marking of sites. The Dangerous Substances (Notification and Marking of Sites) Regulations 1990. Guidance on Regulations* HSR29 HSE Books 1990 ISBN 978 0 1188 5435 1 [www.hse.gov.uk/pubns/hsr29.htm](http://www.hse.gov.uk/pubns/hsr29.htm)
- 46 *The Electricity at Work Regulations 1989. Guidance on Regulations* HSR25 (Third edition) HSE Books 2015 ISBN 978 0 7176 6636 2 [www.hse.gov.uk/pubns/hsr25.htm](http://www.hse.gov.uk/pubns/hsr25.htm)
- 47 *Guidance on storing pesticides for farmers and other professional users* AIS16(rev1) HSE 2012 [www.hse.gov.uk/pubns/ais16.htm](http://www.hse.gov.uk/pubns/ais16.htm)

# Glossary

**ADR** European Agreement concerning the International Carriage of Dangerous Goods by Road.

**ambient** the temperature of an immediate locality.

**ATEX** the collective name for the Explosive Atmospheres Directives 99/92/EC and 94/9/EC of the European Parliament. Both deal with precautions for explosive atmospheres. The first (also known as ATEX 137) focuses on worker safety and the second (ATEX 95 or the ATEX Equipment Directive) focuses on the correct standard of equipment to avoid ignition. Also see EPS.

**auto-ignition temperature (AIT)** the minimum temperature at which a material will ignite spontaneously under specified test conditions. Also referred to as the minimum ignition temperature.

**CDG** Carriage of Dangerous Goods and Use of Transportable Pressure Equipment Regulations 2009.

**CHIP** Chemicals (Hazard Information and Packaging for Supply) Regulations 2009.

**CLP** European Classification, Labelling and Packaging of Substances and Mixtures Regulation 2008.

**COMAH** Control of Major Accident Hazards Regulations 1999.

**combustible** capable of burning in air when ignited.

**DSEAR** the Dangerous Substances and Explosive Atmospheres Regulations 2002.

**enforcing authority** the authority with responsibility for enforcing the HSW Act and other relevant statutory provisions.

**EPS** Equipment and Protective Systems for use in Potentially Explosive Atmospheres Regulations 1996 implementing Directive 94/9/EC of the European Parliament.

**explosive atmosphere** an ignitable mixture of flammable vapour with the air, which has the potential to catch fire or explode if ignited.

**fire-resisting construction** a physical barrier, such as a wall, ceiling or partition that a particular period of fire resistance. See Appendix 1.

**fire resistance** the measure of the ability of a physical barrier to withstand the effects of fire to prevent one or more of the following: the passage of flame and hot gases; the transfer of excessive heat; and maintain the load-bearing capacity of the physical barrier. See Appendix 1.

**flame arrester** a device consisting of an element, a housing and associated fittings which is constructed and used to prevent the passage of flame. An arrester may be categorised as either an end-of-line deflagration arrester, an in-line deflagration arrester or a detonation arrester – see BS EN ISO 16852<sup>14</sup> for requirements and test methods. Most flame arresters consist of an assembly containing narrow passages or apertures through which gases or vapours can flow but which are too small for a flame to pass through.

**flammable** capable of burning with a flame.

**flammable liquid** for the purpose of this book, flammable liquid means a liquid with a flashpoint of 60 °C or below and stored at a near atmospheric pressure.

**flashpoint** the minimum temperature at which a liquid, under specific test conditions, gives off sufficient flammable vapour to ignite momentarily on the application of an ignition source.

**hazard** something that could cause harm to people.

**hazardous area** an area where flammable or explosive gas, or vapour–air mixtures (often referred to as explosive gas–air mixtures) are, or may be expected to be, present in quantities which require special precautions to be taken against the risk of ignition. See L138, regulation 7 and Schedules 2–4.

**hot work** this includes welding or the use of any equipment likely to cause flame, sparks or heat.

**incendive** having sufficient energy to ignite a flammable mixture.

**inert** incapable of supporting combustion; to render incapable of supporting combustion.

**interceptor** (also known as ‘separator’) a device installed in a surface water drainage system to separate out any immiscible solvents and thus prevent them from reaching public drains, sewers or watercourses.

**lower explosion limit (LEL)** the minimum concentration of vapour in air below which propagation of a flame will not occur in the presence of an ignition source. Also referred to as the lower flammable limit or lower explosive limit.

**non-combustible material** a material that fulfils the criteria for non-combustibility given in BS 476 Part 4, Part 11 or equivalent European Harmonised Standard. See Appendix 1.

**permit-to-work (PTW)** a document issued by an authorised person to permit work to be carried out safely in a defined area under specified conditions.

**reasonably practicable** this means balancing the level of risk against the measures needed to control the real risk in terms of money, time or trouble. However, you do not need to take action if it would be grossly disproportionate to the level of risk.

**risk** the chance – however large or small – that a hazard could cause harm.

**ullage space** the free space between the fluid level and the top of its container, to allow for expansion.

**upper explosion limit (UEL)** the maximum concentration of vapour in air above which the propagation of a flame through the mixture will not occur. Also referred to as the upper flammable limit or the upper explosive limit.

**vapour** the gaseous phase released by evaporation from a material that is a liquid at normal temperatures and pressure.

**viscosity** the degree to which a fluid tends to resist relative motion within itself. Examples of viscous fluids are treacle and heavy fuel oils.

**zone** the classified part of a hazardous area, representing the probability of a flammable vapour (or gas) and air mixture being present. See L138, regulation 7 and Schedules 2–4.

## Further information

For information about health and safety, or to report inconsistencies or inaccuracies in this guidance, visit [www.hse.gov.uk/](http://www.hse.gov.uk/). You can view HSE guidance online and order priced publications from the website. HSE priced publications are also available from bookshops.

British Standards can be obtained in PDF or hard copy formats from BSI: <http://shop.bsigroup.com> or by contacting BSI Customer Services for hard copies only Tel: 0845 086 9001 email: [cservices@bsigroup.com](mailto:cservices@bsigroup.com).

The Stationery Office publications are available from The Stationery Office, PO Box 29, Norwich NR3 1GN Tel: 0870 600 5522 Fax: 0870 600 5533 email: [customer.services@tso.co.uk](mailto:customer.services@tso.co.uk) Website: [www.tsoshop.co.uk](http://www.tsoshop.co.uk). (They are also available from bookshops.) Statutory Instruments can be viewed free of charge at [www.legislation.gov.uk](http://www.legislation.gov.uk) where you can also search for changes to legislation.

This guidance is issued by the Health and Safety Executive. Following the guidance is not compulsory, unless specifically stated, and you are free to take other action. But if you do follow the guidance you will normally be doing enough to comply with the law. Health and safety inspectors seek to secure compliance with the law and may refer to this guidance.

This guidance is available online at: [www.hse.gov.uk/pubns/books/hsg140.htm](http://www.hse.gov.uk/pubns/books/hsg140.htm)

© *Crown copyright* If you wish to reuse this information visit [www.hse.gov.uk/copyright](http://www.hse.gov.uk/copyright) for details. First published 09/15