

Storage of flammable liquids in containers



HSG51 (Third edition)
Published 2015

This guidance is for those responsible for the safe storage of flammable liquids in containers at the workplace. It applies to storage of flammable liquids in containers up to 1000 litres capacity.

It explains the fire and explosion hazards associated with flammable liquids and will help you determine how to control the risks in your workplace.

The guidance is one of three documents dealing with fire and explosion hazards associated with flammable liquids. The other two are:

- *Safe use and handling of flammable liquids* HSG140;
- *Storage of flammable liquids in tanks* HSG176.

It supplements the advice contained in *Dangerous substances and explosive atmospheres. Dangerous Substances and Explosive Atmospheres Regulations 2002. Approved Code of Practice and guidance*, L138.

In recognition of the diversity of premises in which flammable liquids are stored and/or used, the guidance now contains discrete topic areas which outline the potential risks and recommended control measures for a number of different types of business.

Contents

Introduction 4

- Dangerous Substances and Explosive Atmospheres Regulations 2002 (DSEAR) 6
- General fire safety legislation 6
- Risk assessment 6

Hazards 8

- Common causes of incidents 8
- Flammable vapours 8

Safety measures 11

Control measures 12

- Design and construction of containers 12
- Marking and labelling 13
- Preventing dangerous accumulations of flammable vapours 13
- Spillage control 13
- Control of potential ignition sources and hazardous area classification 14
- Adverse conditions 15
- Segregation of incompatible substances 16
- Security 16
- Mitigation measures 17
- General safety measures 17

Emergency procedures 20

- Planning 20
- Leaks and spillages 21
- Environment 21
- Recovery 22

General fire precautions 23

- Outdoor storage areas 23

Information and training 25

- Signage 25

Typical storage facilities and arrangements 27

- Outdoor storage 27
- Storage in dedicated (separate) buildings 32
- Storage in storerooms (within other buildings) 35
- Storage in process areas, workrooms, laboratories and similar working areas 39
- Storage of finished products 42
- Temporary storage 43
- Storage and display at retail premises 43
- Storage in a small engineering factory or motor vehicle repair shop 45

Storage of higher flashpoint flammable liquids 47

- Storage locations 47

Design of stores 47
Operations 48
Retail premises 48

Appendix 1 Physical barriers of fire-resisting construction 49

Appendix 2 Mechanical exhaust ventilation (MEV) 50

Appendix 3 Other relevant health and safety legislation 51

Management of Health and Safety at Work Regulations 1999 (the Management Regulations) 51
Control of Substances Hazardous to Health Regulations 2002 (COSHH) 51
CLP and CHIP 51
Provision and Use of Work Equipment Regulations 1998 (PUWER) 52
Equipment and Protective Systems Intended for Use in Potentially Explosive Atmospheres Regulations 1996 (EPS) 52
Planning (Hazardous Substance) Regulations 1992 52
Dangerous Substances (Notification and Marking of Sites) Regulations 1990 (NAMOS) 52
Control of Major Accident Hazards Regulations 1999 (COMAH) 52
Consulting employees and safety representatives 53
Electricity at Work Regulations 1989 53
Carriage of Dangerous Goods and Use of Transportable Pressure Equipment Regulations 2009 (CDG) 53
Health and Safety (Safety Signs and Signals) Regulations 1996 53
Health and Safety Enforcing Authority Regulations 1998 53
Food and Environment Protection Act 1985 (FEPA) 53
Petroleum (Consolidation) Regulations 2014 54

References 55

Glossary 57

Further information 60

Introduction

1 This guidance is for those responsible for the safe storage of flammable liquids in containers at the workplace. It provides information on the fire and explosion hazards associated with flammable liquids and will help you to control the risks. It details practical measures to protect people at work and others who may be affected by the work activity of storing flammable liquids in containers up to 1000 litres capacity.

2 The guidance is one of three documents published by HSE dealing with the fire and explosion hazards associated with flammable liquids. The other two documents are:

- *Safe use and handling of flammable liquids* HSG140;¹
- *Storage of flammable liquids in tanks* HSG176.²

3 This document complements *Dangerous substances and explosive atmospheres. Dangerous Substances and Explosive Atmospheres Regulations 2002. Approved Code of Practice and guidance* L138.³ You will be referred to L138 for additional information.

4 The guidance will also provide a useful source of reference for:

- employees;
- employee-elected representatives;
- trade union appointed health and safety representatives; and
- all other people who have a role in ensuring and assessing the adequacy of health and safety in the workplace.

5 The guidance may also be useful to professional bodies, trade organisations and associations; and other safety specialists to inform the development of more specific guidance for their own members.

6 The objectives of this guidance are to:

- increase awareness of the potential fire and explosion hazards associated with the storage of flammable liquids;
- give guidance on appropriate standards for plant and equipment;
- advise on the need for appropriate fire precautions, maintenance, training and good housekeeping where flammable liquids are stored.

7 In this guidance, 'flammable liquid' means a liquid with a flashpoint of 60 °C or below. This reflects the EU Classification, Labelling and Packaging of Substances and Mixtures Regulation (no 1272/2008) (the CLP Regulation), which sets the criterion for substances and mixtures to be classified as flammable to be those with a flashpoint of up to 60 °C. See Appendix 3 for more information on CLP.

8 This guidance specifically applies to flammable liquids stored above their flashpoint. Primarily this will be flammable liquids categorised under CLP as:

- Category 1: flashpoint <23 °C and initial boiling point ≤35 °C; and
- Category 2: flashpoint <23 °C and initial boiling point >35 °C.

9 However, it also potentially includes:

- Category 3 flammable liquids (under CLP) flashpoint ≥ 23 °C and ≤ 60 °C; and
- combustible liquids with a flashpoint above 60 °C;

where as a consequence of environmental or workplace operational conditions it is reasonably foreseeable they may be stored above their flashpoint. In such circumstance, a similar fire and explosion hazard can exist to that presented by the storage of Category 1 and 2 flammable liquids.

10 For convenience, the term 'lower flashpoint flammable liquids' is used in this guidance to describe the flammable liquids defined in paragraphs 8 and 9.

11 For Category 3 flammable liquids that under normal environmental or workplace operational conditions will always be stored at temperatures below their flashpoint and in consequence will not produce a flammable atmosphere, not all the practical measures described in this guidance may be necessary. This guidance discusses those appropriate for these higher flashpoint flammable liquids.

12 This guidance does not apply to flammable liquids which present special hazards requiring specific precautions, eg ethylene oxide, peroxides, and other liquids which carry a risk of rapid decomposition, polymerisation or spontaneous combustion.

13 This guidance provides a suitable standard for the design of new installations and for major modifications to existing installations. It may be difficult to adopt all the recommendations at existing premises, but any improvements that are reasonably practicable should be made, taking into account the hazards at the site and the cost and feasibility of additional precautions. This document describes ways of achieving an adequate standard of safety. Individual circumstances, for both new and existing installations, may require variations from the recommendations. Alternative designs, materials and methods can be used, as long as they provide an equivalent level of safety. Advice on applying the guidance to specific sites may be obtained from the relevant trade association or a health and safety professional.

14 This guidance primarily deals with risks to people from flammable liquids. However, the release of flammable liquids and their vapours may also have consequences for the environment. In assessing the risks for storage and handling of flammable liquids, including the developing emergency arrangements, the potential for releases of flammable liquids and vapours to cause environmental harm should also be considered. Many of the safety measures recommended to prevent fires and explosions will also minimise the risks to the environment in the event of an incident. However, you should ensure the measures taken are sufficient to guard against harm to the environment. This is especially important when considering alternative safety measures to those discussed in this guidance.

15 Further guidance on environmental considerations is available from:

- the Environment Agency in England
www.environment-agency.gov.uk/business/sectors/wastemanagement.aspx;
- the Scottish Environment Protection Agency (SEPA) in Scotland
www.sepa.org.uk/waste.aspx;
- Natural Resources Wales (NRW) Cyfoeth Naturiol Cymru
<http://naturalresourceswales.gov.uk>.

16 The main health and safety legislation relevant to sites storing flammable liquids is outlined below and other relevant health and safety legislation is listed in Appendix 3. For the latest information on health and safety legislation, visit the HSE website www.hse.gov.uk.

Dangerous Substances and Explosive Atmospheres Regulations 2002 (DSEAR)

17 Avoiding fire or explosion at workplaces manufacturing, storing or using flammable liquids can be ensured by compliance with DSEAR. The primary purpose of DSEAR is to protect the safety of workers and others who may be at risk from dangerous substances that can cause a fire, explosion or similar energy-releasing event, such as a runaway exothermic reaction.

18 DSEAR is enforced by HSE or local authority inspectors, except at commercial premises holding a petroleum storage certificate (previously a petroleum licence) where the Regulations are enforced by Petroleum Enforcement Authorities (PEAs) in respect of any activities related to refuelling motor vehicles. At most workplaces, the local fire and rescue authority or the joint fire and rescue board for the area will enforce those parts of DSEAR that relate to general fire precautions (see below).

General fire safety legislation

19 General fire safety requirements in the workplace in England and Wales are applied through the Regulatory Reform (Fire Safety) Order 2005 (SI 2005/1541). The Scottish equivalents are the Fire (Scotland) Act 2005 (2005 (asp 5)) and the Fire Safety (Scotland) Regulations 2006 (SSI 2006/456). The legislation consolidated and revoked legislation that previously covered general fire safety, including the requirement for fire certification. Current legislation requires the employer to carry out a risk assessment to determine the general fire safety requirements for their workplace and implement those requirements, including maintaining a general fire safety management plan.

20 General fire safety legislation is normally enforced by the local fire and rescue authority or in Scotland, the Scottish Fire and Rescue Service. However, there are other enforcing authorities for certain specific workplaces/worksites. HSE is the enforcing authority for general fire safety in shipbuilding and on most construction sites. The Office for Nuclear Regulation (ONR) is the enforcing authority for fire safety in licensed nuclear premises.

21 Any general fire safety provision which could be imposed by regulations 1–6, 8, 9 and 11 of DSEAR is covered instead under this general fire safety legislation, with enforcement responsibility falling to the relevant authority, depending on the activity at the premises.

Risk assessment

22 Where flammable liquids are intentionally present at the workplace, there is a specific requirement under DSEAR for you to identify the potential risks such activity may pose to your employees and others whose health and safety may be affected. The outcome of this risk assessment will determine the measures to be taken to eliminate or reduce these risks so far as reasonably practicable. This requirement is in addition to the requirements under the Management of Health and

Safety at Work Regulations (the Management Regulations – see Appendix 3) but a single risk assessment may be sufficient for both.

23 The risk assessment required under DSEAR may be carried out as part of the risk assessment requirements of the Management Regulations and general fire safety legislation, which follows the same approach as that used in health and safety legislation. In particular, given the need to take account of the presence of flammable liquids in the general fire safety risk assessment, you may find it of benefit to carry out the required risk assessments as a consolidated exercise.

24 A risk assessment should be carried out regardless of the quantity of flammable liquid present at the workplace, as it will enable you to decide whether existing measures are sufficient or whether any additional controls or precautions are necessary. As well as assessing the normal activities within the workplace, you will also need to assess non-routine activities, such as maintenance work, where there is often a higher potential for fire and explosion incidents to occur. If there is no risk to safety from fires and explosions, or the risk is trivial, no further action is needed. If there are risks, then you must consider what you need to do to comply fully with the requirements of DSEAR.

25 Further guidance on the risk assessment requirement under DSEAR is given in L138.

26 The DSEAR risk assessment is quite wide-ranging and includes requirement to consider whether a flammable liquid needs to be present in the workplace and if so, whether it might be substituted for one that is less flammable, eg has a higher flashpoint. You also need to determine how the flammable liquid is to be stored and handled to ensure the risks are reduced so far as reasonably practicable. This includes the decision whether flammable liquids should be stored in tanks, or if storage in containers is acceptable. This guidance assumes that you have carried out these aspects of the DSEAR risk assessment and concluded that the storage of flammable liquids in containers is appropriate at the workplace.

27 The performance objectives and control measures described in this guidance reflect current and readily achievable good industrial practice and are intended to aid the task of minimising the risks associated with the storage of flammable liquids in containers for a wide range of storage scenarios. You are free to take alternative measures, or vary those described, if you have determined through your risk assessment that they provide at least an equivalent level of health and safety.

Hazards

28 The main hazards from the use of flammable liquids are fire and explosion. For a fire or explosion to occur it requires three things to come together:

- flammable liquid;
- source of ignition; and
- air.

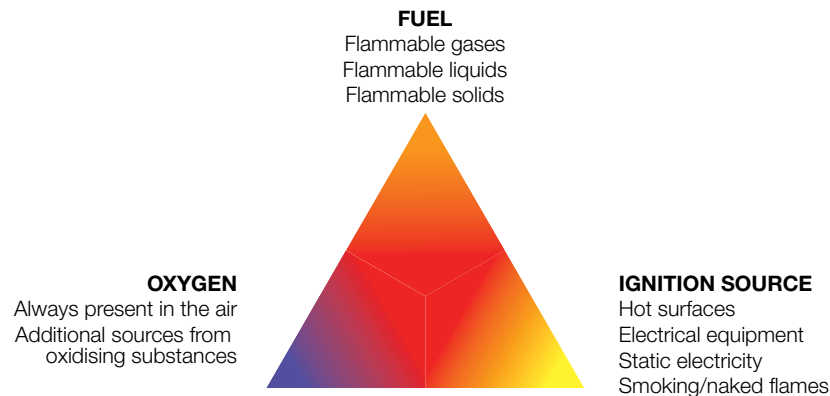

Figure 1 The fire triangle

Common causes of incidents

29 Fires or explosions can occur when vapours or liquids are released from a controlled environment to areas where there may be an ignition source, or, alternatively, when an ignition source is introduced into a controlled environment. Common causes of such incidents include:

- lack of training and awareness of the properties of flammable liquids;
- inadequate design of equipment;
- failure or malfunction of equipment;
- inadequate installation or maintenance;
- procedural errors or omissions;
- inadequate control of potential ignition sources, including electrostatic discharge;
- dismantling or disposal of plant and equipment that contains or has contained flammable liquid;
- hot work on or close to flammable liquid containers;
- exposure to heat from a nearby fire.

30 Incidents involving flammable liquids commonly arise during transfer operations, including:

- movement from storage and within premises;
- dealing with spillages.

Flammable vapours

31 Combustion of liquids occurs when flammable vapours released from the surface of the liquid ignite. The flashpoint is the lowest temperature at which a flammable liquid gives off vapours in sufficient concentration to form an ignitable

mixture with air near the surface of the liquid. Generally, a flammable liquid with a flashpoint below ambient temperature will always give off sufficient vapour to form an ignitable mixture. Ignitable mixtures are less likely to form from liquids with a flashpoint greater than the ambient temperature unless they are heated, mixed with low flashpoint materials or released under pressure as a mist or spray. However, flammable liquids below their flashpoint can also be readily ignited if present as a thin film over a surface, even one that is non-combustible, or when spilt onto absorbent material such as clothing and packaging material.

32 The amount of flammable vapour given off from a liquid, and therefore the extent of the ignitable flammable vapour mixture with air depends on a variety of factors, including the temperature of the liquid, its volatility, the surface area of the liquid exposed, how long it is exposed for, and air movement in the locality.

33 The extent of the ignitable mixture is referred to as the explosive atmosphere, ie the mixture of flammable vapour with the air, which has the potential to catch fire or explode. An explosive atmosphere does not always result in an explosion but, if it does catch fire, the flames will travel quickly through it. If this happens in a confined space (eg within plant or equipment, or a compartment, room or building), the rapid propagation of the flames through the explosive atmosphere may result in an increase in pressure and subsequent damaging explosion.

Explosion limits

34 The explosion limits define the concentrations (normally by volume) of vapour/air mixtures that will propagate a flame. The lower explosion limit (LEL) is the minimum concentration of vapour in air below which propagation of a flame will not occur in the presence of an ignition source. This may also be referred to as the lower flammable limit (LFL) or lower explosive limit. The upper explosion limit (UEL) is the maximum concentration of vapour in air above which the propagation of a flame will not occur. This may also be referred to as the upper flammable limit (UFL) or the upper explosion limit. The explosion limits vary for different flammable liquids, with typically many in the range of circa 1% (LEL) to between 10 and 20% (UEL). While flames will not propagate through flammable vapour mixtures with air above their UEL, they are still readily ignitable at their interface with air; in which event, a fire will result.

Vapours

35 Some mixtures (preparations) that contain a flammable liquid (for example, water/solvent mixtures or emulsions) may only release flammable vapours slowly. However, the vapours may still achieve sufficient concentration to form an ignitable mixture with air and for the mixture to be assigned a flashpoint, even though the rate of release of the vapours may be insufficient to sustain combustion.

36 For such mixtures with a flashpoint <23 °C (and those mixtures with a flashpoint above this but which as a consequence of environmental or workplace operational conditions it is reasonably foreseeable they may be stored above their flashpoint) the full implementation of the measures detailed in this guidance may not be necessary. This should be determined through the risk assessment, taking particular account of the advice and guidance available from the supplier, including the safety data sheet (SDS) for the mixture.

Viscosity

37 Other physical properties, such as viscosity, auto-ignition temperature (AIT) and conductivity, also indicate the potential extent of an explosive atmosphere and possible ignition sources.

38 The viscosity of the substance/mixture (preparation) is an important property, as it determines how far any spillages will spread and therefore the size of any exposed surface of flammable liquid. Solvents generally have a low viscosity and when spilt, spread quickly, allowing a rapid build-up of vapours from the surface of the liquid. Some liquid formulations, such as paints and resins, may have a high viscosity; if they are spilt they spread and produce vapours more slowly than would the individual solvent constituents.

Ignition

39 The ignition energy required to ignite flammable liquid vapours is relatively small. The typical minimum ignition energy (MIE) is in the range of 0.1 to 10 mJ, which can be readily produced in much plant and equipment in the form of heat, electrical, mechanical or chemical energy. In addition to the potential ignition sources presented by external plant and equipment, you should also consider the properties of the flammable liquid itself to ensure it is not handled in a manner that might result in incident. For example, ensure it is not heated above its AIT; or where it has low (electrical) conductivity (ie less than 50 picoSiemens (pS)) it is handled in a manner to guard against incendive electrostatic discharge that is potentially capable of causing ignition of the flammable vapours.

Physical environment

40 The physical environment in which flammable liquids are handled can also determine how the hazards may develop. Whether the released vapour is able to build up to form an explosive atmosphere will depend on whether it can freely disperse and if indoors the degree of ventilation of the enclosure, taking account of any obstructions and plant congestion that might interfere with this.

41 You should also consider the proximity of pits, gulleys and drains to where flammable liquids are stored and handled to ensure the ingress and accumulation of any releases of flammable liquids and/or vapours is prevented. Flammable liquid vapours are heavier than air and will unless dispersed tend to accumulate at lower areas. If ignition occurs in such locations, the flame is likely to travel or 'flash' back to the source of the vapours, ie the flammable liquid.

Safety measures

42 The following safety measures apply to the storage of lower flashpoint flammable liquids; ie extremely flammable liquids; highly flammable liquids; and those flammable liquids that may be stored at temperatures above their flashpoint (see paragraphs 8–9).

43 For higher flashpoint flammable liquids (see paragraphs 11 and 39) amendment and variation can be appropriate as determined through your risk assessment. Guidance on appropriate safety measures for these flammable liquids may be found in paragraphs 247–263.

44 Where you have, through your DSEAR risk assessment, concluded that the storage of flammable liquids in containers is appropriate at your workplace, DSEAR requires the following safety measures and procedures to be considered:

- control measures;
- mitigation measures;
- general safety measures;
- emergency procedures to be implemented in the event of an incident.

45 Control measures are those measures taken to prevent an incident from occurring. Mitigation measures are those measures taken should an incident occur to limit its extent and effect. General safety measures are those measures intended to ensure the workplace and facilities within this – along with the work processes – are designed, constructed and maintained to reduce the risks arising from the dangerous substance so far as reasonably practicable. The purpose of emergency procedures is to enable control or containment of an incident to allow sufficient time for people to escape or be evacuated to a place of safety; and following the incident, make the situation safe.

46 The following sections detail the performance objectives and requirement of these measures and procedures specifically pertinent to the safe storage of lower flashpoint flammable liquids in containers.

Control measures

Design and construction of containers

47 The primary safeguard to prevent the release of flammable liquids is provided by the container. It is therefore critical to ensure that it is of appropriate design for the duty. The materials of construction should be compatible with the chemical and physical properties of the flammable liquid to ensure that no interaction occurs which might cause leakage. All the container openings should be equipped with a secure and well-fitting cap or lid to resist the escape of flammable liquid or vapours, including if the container falls or rolls over.

48 There are specific requirements under the Carriage of Dangerous Goods and Use of Transportable Pressure Equipment Regulations 2009 (CDG) and to a lesser extent in the CLP Regulation (see Appendix 3) that cover the suitability of containers for flammable liquids. Where the container complies with these requirements for the particular flammable liquid, eg to an appropriate UN Performance Tested Type, it is also suitable to be used for storage.

49 If you are producing the flammable liquid at the workplace and intend to store this in containers prior to its use on site, you should ensure suitable containers are used. Containers compliant with the supply and transport regulations discussed above will satisfy this requirement.



Figure 2 Various types of container

50 Where glass or other fragile containers are used, you should protect them from impact damage. Measures to achieve this may include:

- retaining/providing additional packaging for physical protection and possibly containment/absorption of leaks;
- dedicated storage location; and/or
- specified handling procedures.

Marking and labelling

51 Individual containers must be clearly marked to indicate their contents and the degree of flammability. Flammable liquids arriving on site will be marked in accordance with CDG and the CLP Regulation. This labelling is likely to be sufficient to help you determine the storage arrangements required for the flammable liquid containers (see Appendix 3).



Figure 3 Examples of flammable liquid packaging labels

52 Where the flammable liquid is produced and used at the workplace, the containers used to store it before use should be appropriately labelled. Containers compliant with the supply and transport regulations discussed above will satisfy this requirement. If you choose to develop and use your own labelling system, you should ensure it is fully understood by your employees and others who may encounter it, for example the emergency services.

Preventing dangerous accumulations of flammable vapours

53 Locations where containers that contain (or have contained) flammable liquids are stored should be suitable to prevent the dangerous accumulation of flammable vapours that might occur as a result of leakage from the container. The ideal location is an unenclosed and uncongested site in the open air at ground level that enables any vapours to rapidly disperse to safe levels.

54 Where outdoor storage of containers is not reasonably practicable, they may be kept indoors, provided there is adequate ventilation to prevent the dangerous accumulation of flammable vapours that may arise as a result of foreseeable leaks from the containers. Further guidance on this is given in the examples of storage facilities detailed below.

Spillage control

55 Locations where flammable liquids are stored should have adequate means to prevent the uncontrolled spread of any spillages or leaks beyond the confines of the storage area. Typically, this is achieved by ensuring the base or floor of the storage

area is impervious and enclosing this with an impervious sill, low bund wall or drainage channel to contain a volume that is at least 110% of the capacity of the largest container, where these are of metal construction. Plastic containers are especially vulnerable in the event of a fire, with the potential for the entire inventory to fail within a period of perhaps only 10 minutes. Your spillage control arrangements should take this possibility into account. Guidance may be found in the joint CBA/SIA publication *Guidance for the storage of liquids in intermediate bulk containers*.⁴

56 Providing a slight gradient to the surface of the storage area will also allow any spillages or leaks to flow away from beneath the containers. Supplementing this with drainage arrangements to a remote sump, interceptor or separator, or other safe place may be appropriate where a larger containment volume is required or if you conclude the potential risk posed by the spillage or leak of flammable liquid is unacceptable.

Control of potential ignition sources and hazardous area classification

57 Preventing leaks and possible accumulation of dangerous quantities of flammable liquid or vapours is the first priority. However, you should anticipate that flammable liquids or vapours could still escape and have adequate and sufficient control measures in place to prevent their ignition.

58 Potential ignition sources can be of various forms of energy – including heat, electrical, mechanical and chemical – and may be presented by fixed and mobile plant and equipment, or transient activity. Examples include:

- naked flames, including welding and cutting equipment;
- smoking and smoking equipment;
- electrical lighting, power circuits and equipment;
- personal electrical equipment including mobile phones, computers and tablets;
- mechanically powered plant;
- processes that involve the generation of sparks;
- hot surfaces;
- static electricity;
- lightning.

59 You should consider the need for lightning protection where it could be an initiator of a major incident.

60 Where plastic containers are used, you should assess the possibility of ignition from electrostatic discharge, especially where they are being used to store low-conductivity flammable liquids (see paragraph 39).

61 Under regulation 7(1) of DSEAR, you must determine the potential extent of a flammable atmosphere that could result from leaks of flammable liquids stored at or above their flashpoint (or where this might be anticipated) and ensure all potential ignition sources are excluded from such areas. This process is referred to as hazardous area classification (HAC), the requirements for which are detailed in L138 (see regulation 7 and Schedules 2–4).

62 Within these hazardous areas, only equipment and protective systems that are ATEX-certified in compliance with the Equipment and Protective Systems Intended for Use in Potentially Explosive Atmospheres Regulations 1996 (EPS) should be used (see Appendix 3).

63 The extent of the hazardous areas will depend on the storage arrangements. Guidance on this may be found in the chapter 'Typical storage facilities and arrangements'.

64 Further advice and guidance on HAC includes:

- BS EN 60079-10-1;⁵
- Energy Institute's *Model Code of Safe Practice Part 15: Area Classification Code for Installations Handling Flammable Fluids*.⁶

65 Where a hazardous area classification study has been carried out under regulation 7 of DSEAR, this should be recorded in the form of a drawing which:

- identifies the hazardous areas and types of zones;
- shows the extent of the zones in both plan and elevation (ie illustrates the three-dimensional nature of the hazardous zone);
- is supplemented with relevant information as to the flammable liquids that it applies to.

66 HAC is intended to consider those leaks that may be expected to occur during normal operational and maintenance activities, which include accidental spillage. However, you should also consider the full range and nature of the potential leaks that might occur and put in place appropriate measures to reduce the risk of ignition and escalation of a fire.

67 Similarly, you should also consider the possibility that a potential ignition source may be outside the designated hazardous areas defining the nominal extent of the explosive atmosphere; for example an incandescent particle from a fire, hot work, exhaust or possible plant failure. The risk of such occurrence should be reduced by appropriate plant design and control of work activities.

Adverse conditions

68 You should ensure that the ambient conditions the flammable liquid containers are subject to in storage will not lead to deterioration of the container, or its failure resulting in release of flammable liquids or vapours.

69 You should ensure that the containers have sufficient ullage space to allow for liquid expansion that may be expected to occur at the maximum ambient temperature the containers are expected to be subject to without becoming overfilled and liable to failure. You should have adequate controls in place to prevent containers being overfilled where they are used for storing waste flammable liquids, especially those where the waste liquids may be added over an extended period. (Note: under transport legislation, specific standards for ullage space require that the container should not be filled so as to become liquid full at a temperature of 50 °C.)

70 You should take account of the potential warming that may occur where the containers are stored in direct sunlight or in close proximity to transparent roof lights. Plastic containers in particular can degrade with prolonged exposure to sunlight.

71 You should also ensure that the flammable liquid/flammable liquid-based product remains stable and free from adverse chemical reaction, eg decomposition or oxidation to form substances that could change its nature and increase the risk of incident at the ambient temperatures the product is likely to be exposed to

during storage. The storage of products that are 'chemically unstable substances', ie those that can undergo self-sustaining chemical reaction, is not covered in this guidance (see paragraph 12).

72 Where necessary, provide shading from direct sunlight. Any shading or weather protection should be of a lightweight non-combustible construction (Reaction to fire category: minimal or low – see Appendix 1) with open sides so as not to restrict ventilation around the containers.

73 If heating is provided in the building, you should ensure this cannot adversely affect the container or the contents. Direct contact with any hot surfaces, eg hot water or steam pipes, should be prevented by suitable barrier or grills.

Segregation of incompatible substances

74 Flammable liquids should be stored separately from incompatible substances. *Chemical warehousing: The storage of packaged dangerous substances HSG71*⁷ gives guidance on the safe storage of incompatible chemicals and includes segregation recommendations.

75 Stocks of combustible materials, such as packaging, should not be kept in the flammable liquid store. Potentially, this could be the first material ignited and a subsequent fire would then be likely to compromise the safe storage of the flammable liquids containers.

Security

76 To minimise the risk of fire or explosion, you should take appropriate precautions to prevent uncontrolled or unauthorised access, including trespass, to the stored flammable liquid containers. These precautions should include appropriate arrangements to secure the site against trespass outside normal work hours; and in particular guard against the possibility of tampering, vandalism and arson.

77 The standard of security required will depend, among other factors, on the consequences of a fire or explosion involving the stored flammable liquids. Unless the site itself is secure, access to outdoor storage areas should be prevented by suitable fencing and lockable gates. Similarly, you should ensure storage buildings are secure and the doors are fitted with locks. In addition to ensuring the gates and doors to storage facilities are locked outside normal work hours, you need to determine if uncontrolled/unauthorised access should also be prevented during the periods your premises are working. One way of achieving this is to keep the area locked with access to the keys being restricted to authorised people.

78 As necessary, you may consider additional security measures including CCTV, intruder alarms, security patrols etc appropriate.

79 Ensure that the security measures adopted do not compromise other safety requirements. Fencing such as palisade, welded mesh and chain link fencing should be used that will not obstruct ventilation and is constructed from non-combustible material. Adequate means of escape should be provided from fenced compounds, buildings and storerooms; ensure gates and doors designated as fire exits can be readily opened whenever the compound, building or storeroom is occupied. See also general fire precautions in paragraphs 121–125.

80 Compound fences, walls and gates; and building walls, roof and doors should be properly maintained to ensure they remain fit for purpose in providing adequate security.

Mitigation measures

Separation

81 You should ensure that flammable liquid storage areas and facilities are adequately separated from:

- site boundaries;
- occupied buildings;
- process areas;
- fixed ignition sources and other features that pose a threat;
- other incompatible materials and dangerous substances within storage area or facility.

82 The purpose of the separation is to delay and ideally prevent an incident elsewhere (on site or off-site) threatening the flammable liquid storage area/facility. Equally, in the event of incident in the area/facility itself, it is intended to allow people to escape from the effects of the incident without suffering harm. Limiting the scale or nature of an incident and delaying its escalation also provides opportunity to implement emergency procedures.

83 Separation may be provided by distance alone, or where there are space limitations, by a physical barrier of fire-resisting construction. The requirements for separation, whether by distance or use of a physical barrier of fire-resisting construction, and the constraints regarding the use of such barriers, will depend on the storage arrangements. See chapter 'Typical storage facilities and arrangements'.

Personal protective equipment (PPE)

84 The provision of suitable personal and respiratory protective equipment (PPE/RPE) should not be a substitute for providing appropriate safety measures on the plant, facilities, equipment and work processes. The purpose of PPE, including as appropriate RPE, should be where this addresses a residual risk that remains after implementing all such appropriate safety measures to these workplace items and work processes that it is reasonably practicable to do so.

85 Where there is a risk of electrostatic discharge causing ignition, PPE (ie footwear and as appropriate, clothing) should be provided to guard against this risk. Risk assessment should also inform whether, due to the nature of the work activities and operations carried out by the employee, the PPE clothing provided should be flame retardant.

General safety measures

Design and construction

86 The storage facility should be designed, constructed and operated to minimise the risk of damage to the containers, their deterioration, and adverse break-down of the flammable liquid/flammable liquid product.

87 You should develop and implement operational procedures to ensure the correct storage, stock rotation and inspection frequencies necessary for safe storage. These procedures should take account of the recommended storage conditions and maximum storage times for the containers and/or flammable liquid/flammable liquid product. For supplied flammable liquid/flammable liquid product in containers, information regarding storage requirements should be contained in the product SDS. Where you produce a flammable liquid/flammable liquid finished product, you will be responsible for determining the requirements for safe storage, and if you are a supplier, production of the SDS.

88 As well as checking for leaks, inspections should also check for damage or deterioration to the containers, packaging and racking where installed. Containers and racking may need protection against corrosion (for example by painting) and vehicle impact (for example by bollards or a suitable barrier).

89 The storage facility should be solely dedicated to the storage of flammable liquids in containers. It should not be used for any activities where spillages or escape of flammable liquid vapours may occur; for example sampling, dispensing, mixing and repacking. Such operations should be carried out in a separate area. See *Safe use and handling of flammable liquids* HSG140¹ for further guidance.

90 The containers should be stored in a manner that facilitates safe handling. Where you intend to stack the containers, you should check with the supplier that the containers are suitable for stacking and any limitations as to stack size. Stacks should be stable, allow for any leaking container to be readily spotted, and be arranged in such manner to enable such container to be easily removed.

91 Storage should preferably be on pallets or suitably designed racking systems.

92 Except where a suitably designed racking systems is provided, for practical operational purposes, the limit for metal drums of nominal size 200 litres stacked vertically will be three high; horizontally ('on the roll') four high. It is generally recommended that filled intermediate bulk containers (IBCs) are stacked no more than two high and then only when they are designed to stack together and ground conditions are suitable.

93 Drums stored on their sides can be prevented from moving by using suitable chocks.

94 Containers should not be sited in a manner that will interfere with or obstruct the free movement of air through ventilation openings or the effectiveness of exhaust ventilation where fitted. Nor should containers be sited in a position where they might obstruct escape routes or fire exits.

Maintenance and modifications

95 Many incidents involving flammable liquids occur during maintenance and repairs.

96 The likelihood is increased if the work is done by staff or outside contractors who have little knowledge of the hazards associated with flammable liquids. You should only employ competent contractors who have the necessary skills, knowledge and experience to carry out the work safely and without risks to health and safety. *Managing contractors: A guide for employers* HSG159⁸ gives sound practical advice for selecting and managing contractors.

97 The Management Regulations (see Appendix 3) place duties to ensure safe working practices on both the company using the services and the contractor.

98 Maintenance work should not be carried out until:

- the potential hazards of the work have been clearly identified and assessed;
- the precautions needed have been specified in detail;
- the necessary safety equipment has been provided; and
- adequate and clear instruction has been given to all those concerned.

99 In most cases, a permit-to-work (PTW) system should be used to control maintenance operations in areas where flammable liquids are stored or used. PTWs are formal management documents. They should only be issued by those with clearly assigned authority to do so, and the requirements stated in them must be complied with before the permit is issued and the work covered by it is undertaken. Individual PTWs need to relate to clearly defined individual pieces of work. PTWs should normally include:

- the location and nature of the work intended;
- identification of the hazards, including the residual hazards and those introduced by the work itself;
- the precautions necessary, for example, isolations;
- the personal protective equipment required;
- the proposed time and duration of the work;
- the limits of time for which the permit is valid; and
- the person in direct control of the work.

100 A range of guidance on PTW systems may be found on HSE's website www.hse.gov.uk and in *Guidance on permit-to-work systems: A guide for the petroleum, chemical and allied industries* HSG250.⁹

101 Some simple controls will reduce the risks of fire and explosion during maintenance involving hot work. You need to make sure that all flammable or combustible materials are removed from the work area. If it is not reasonably practicable to remove such materials, then you could position suitable screens or partitions to protect the hazardous inventory. Once the work has finished, you should continue to inspect the area for at least an hour to ensure that there is no smouldering material present. Depending on the nature of the work, further periodic checks may be required for some time after this.

Emergency procedures

102 Regulation 8 of DSEAR requires you to make suitable arrangements to deal with accidents, incidents and emergencies involving dangerous substances. Detailed discussion of this requirement is provided in L138.

103 These arrangements are in addition to the measures already required by regulation 6 of DSEAR to eliminate or reduce risk (by design, and safe operation, instruction and training).

104 With respect to the storage of flammable liquids, you should consider the conclusions of your risk assessment about the likelihood and scale or magnitude of the predicted effects that foreseeable unplanned events may potentially have on people. The resulting emergency arrangements put in place, which include the evacuation, escape or rescue of people, should aim to minimise the impact of an unplanned event.

105 You need to draw up procedures for dealing with the range of foreseeable unplanned events possible at the workplace, including fire. This should take account of:

- the nature and quantities of the flammable liquids stored;
- the location of the storage facility and its design; and
- the people, both on site and off site, who may be affected.

106 You may not be able to achieve full mitigation and control of all foreseeable accidents, incidents and emergencies solely by your own means. Rather, this is typically achieved by a combination of workplace emergency arrangements and those provided by the emergency services.

Planning

107 Where foreseeable incidents may affect people or property beyond the site boundary, the emergency services should be consulted when preparing the emergency plans.

108 Formal on-site and off-site emergency plans are required at sites subject to the Control of Major Accident Hazards Regulations (COMAH) (see Appendix 3). Further guidance on this is available in *Emergency planning for major accidents: Control of Major Accident Hazards Regulations 1999 (COMAH) HSG191*.¹⁰

109 For an effective emergency response, arrangements should be in place to call the emergency services without unnecessary delay, and to have a designated person to meet the emergency services on their arrival to advise them of the situation. Sufficient information should be available on the nature, quantity and location of the flammable liquids and any other substances on site that may have an effect on an incident.

110 When developing your emergency procedures, you should contact the emergency services to advise them of your work activity and to provide information as to the nature and quantity of the flammable liquids stored (and any other dangerous substances present) if requested.

111 In addition to dealing with any fire, the fire and rescue service is also likely to be able to assist in dealing with other non-fire emergencies, such as released or spilled dangerous substances.

112 Initiating emergency procedures at the earliest stage of an incident can significantly reduce the impact on people and the premises. The primary requirement is to ensure people's safety. The requirement to mitigate the effects of the accident, incident or emergency should have regard to this objective and the need to avoid exposing people to any unnecessary risks.

Leaks and spillages

113 Prompt action to deal with leaks from individual containers can prevent escalation to a larger incident, including fire. You should have arrangements in place to deal with these situations. The supplier's SDSs should detail any specific action to be taken for dealing with spillages. You need to have these available for all the flammable liquids stored on site.

114 Consider providing non-combustible absorbent granules or other means for clearing up small spills. Where used, you should have arrangements for their safe disposal.

115 The nature of the site will dictate the level of precautions needed. With respect to fire, these could vary from providing suitable fire extinguishers and/or fire hose reels to tackle a fire in its initial stages, to using monitors or deluge systems to apply cooling water over the container stacks. It is recommended that such provision is discussed with your local fire and rescue authority or the joint fire and rescue board.

116 Whatever firefighting equipment is provided, you should ensure that the people expected to use it are trained and practised in how to do so, without exposing themselves or others to any unnecessary risk from the fire.

117 The presence of a dangerous substance can significantly enhance the speed at which a fire develops and also the amount of smoke and fume evolved. You should take account of this in determining whether the general fire precautions for your workplace are adequate (see paragraphs 121–125).

Environment

118 The potential consequences of spillages of flammable liquid, with or without fire, to cause environmental harm should also be considered. Advice on assessing environmental risks can be obtained from the Environment Agency in England; the Scottish Environment Protection Agency (SEPA) in Scotland; or the Natural Resources Wales (NRW) in Wales (see paragraph 15).

119 In the event of fire, the potential for fire water run-off can place a major strain on normal drainage facilities and interceptors or special drainage schemes may be necessary, particularly at large installations, to minimise the risk of contaminating local water courses. In developing appropriate emergency procedures for the workplace, consultation with the appropriate agencies and the local fire authority may be appropriate. Relevant guidance on this topic can be found in:

- *Control of fire-water run-off from CIMAH sites to prevent environmental damage* EH70;¹¹
- *Containment systems for the prevention of pollution* C736 CIRIA.¹²

Recovery

120 You should also have arrangements making the situation safe after an incident, for example:

- safe recovery and clean up of spilt flammable liquids;
- repair or decommissioning of leaking or unsafe plant;
- making safe damaged or unstable buildings.

General fire precautions

121 'General fire precautions' (the equivalent term 'General fire safety measures' is used in Scotland) are primarily concerned with ensuring people can safely escape to a place of safety in the event of a fire in the workplace. This includes provision of:

- adequate and appropriate means of detection and giving warning in case of fire;
- adequate means of escape;
- suitable means of fighting fire;
- specifying the action to be taken in the event of fire; and
- appropriate and adequate training of staff in the company's fire safety procedures.

122 You are responsible for carrying out a risk assessment to determine the general fire safety requirements for your workplace. As part of this, you should consider the potential impact of fire involving the stored flammable liquids and adapt the general fire precautions as necessary so they remain sufficient to ensure people's safety in the event of fire.

123 General fire precautions are subject to separate legislation (see paragraphs 19–21). This includes the requirement for you to ensure they are sufficient for people's safety in the event of a fire involving dangerous substances at the workplace. The provisions of regulations 1–6, 8, 9 and 11 of DSEAR, as they relate to general fire safety, are embodied in this general fire safety legislation.

124 Detailed consideration of general fire precautions is outside the scope of this guidance. Guidance on how to comply with the law relating to general fire safety requirements and how to carry out a fire risk assessment can be found:

- for England and Wales, in 'Fire safety in the workplace' www.gov.uk/workplace-fire-safety-your-responsibilities;
- for Scotland, in 'FireLaw – General guidance' www.scotland.gov.uk/Topics/Justice/public-safety/Fire-Rescue/FireLaw;
- for England and Wales, 'Fire safety risk assessment: factories and warehouses' <https://www.gov.uk/government/publications/fire-safety-risk-assessment-factories-and-warehouses>;
- for Scotland, 'Factories & Storage Premises' www.scotland.gov.uk/Topics/Justice/public-safety/Fire-Rescue/FireLaw/FireLaw/SectorSpecificGuidance/FactoriesStorage;
- for construction sites, *Fire safety in construction* HSG168.¹³

125 Further detailed advice may be found in BS 9999.¹⁴

Outdoor storage areas

126 General fire precautions legislation applies to the entire workplace. This includes outdoor work areas. The following guidance will help you to determine adequate general fire precautions for outdoor storage facilities.

Detection and giving warning in case of fire

127 There should be an effective means of giving warning in case of fire in the storage area. It should be audible to all those likely to be affected by the fire. This may vary from small storage areas, where a shout of 'fire' might suffice, to larger areas where a klaxon or siren might be required. An assembly point in a safe location should be identified for people evacuating from such areas, where they can be accounted for.

Adequate means of escape

128 The layout of drum stacks should be planned and controlled to avoid dead-end situations where possible, ie where escape is only possible in one direction. Any that cannot be avoided should be as short as possible. Escape routes should be obvious, with directional escape signs as required. These signs should comply with the Health and Safety (Safety Signs and Signals) Regulations (see Appendix 3). The gangway widths between stacks should remain constant, or increase, along the route towards the exit. Operational needs should ensure that the gangway widths are adequate, but wherever possible, they should have a minimum width of 1.5 metres.

129 If the store is within a fenced security compound, at least two exits, well spaced apart, should normally be provided so that people can turn away from a fire and find an exit. A single exit in small stores may be sufficient if the distance from any part of the store to the exit, measured around the containers, is not more than 25 metres. Exits should open outwards and be immediately openable by people making their escape.

Suitable means of fighting fire

130 An adequate number of fire extinguishers should be provided at the storage area. Their primary purpose is to enable an outbreak of fire in its early stages to be tackled, reducing the risk to people and enabling them to make their escape.

131 They should be positioned in conspicuous locations on the escape routes, such that no one in the storage area needs to travel more than 30 metres to reach an extinguisher. Unless the extinguisher is clearly visible, you will need to identify its location by appropriate safety signs. Such signs should comply with the Health and Safety (Safety Signs and Signals) Regulations.

132 To reduce the risk of corrosion it is sensible to keep extinguishers off the ground and provide protection against the weather.

133 Extinguishers should be to a recognised standard such as BS EN 3-7¹⁵ and be suitable for tackling fires involving the flammable liquids stored. This is particularly important where alcohol-based flammable liquids are stored. The nominal size 9 kg dry powder or 9-litre foam extinguisher is recommended. Such a size of extinguisher combines ease of handling with a reasonable firefighting capability. You should ensure that anybody expected to use a fire extinguisher is properly trained.

Information and training

134 Adequate training and knowledge of the properties of flammable liquids present on site are essential for their safe storage and the implementation of emergency procedures in the event of an incident.

135 Training is a requirement of the Management Regulations and DSEAR (see Appendix 3 and paragraphs 17–18). Carrying out risk assessments required by these Regulations will identify how much information, training and retraining are needed. Further guidance is available in L138.

136 You should inform all staff on the site about the hazards of storing flammable liquids, and about the need to exclude sources of ignition and heat from the designated storage areas. Those responsible for the operation of the store also need to receive specific training in how to deal with spillages and leaks, and emergency procedures.

137 Periodic retraining will normally be required. The training should include the following aspects:

- the types of flammable liquid stored, their properties and hazards;
- general procedures for safe handling;
- use of PPE (and RPE);
- housekeeping;
- reporting faults and incidents, including minor leaks and spills; and
- emergency procedures, including response to spillages, raising the alarm, calling the fire and rescue service and the use of appropriate firefighting equipment.

138 You should have written procedures for controlling the risks from the storage of flammable liquids, and these should be used as the basis for training.

Signage

139 The Health and Safety (Safety Signs and Signals) Regulations (see Appendix 3) and DSEAR regulations 7(3) and 10 require employers to post appropriate safety signs where identified significant risk remains following implementation of the other safety measures. The intention of posting safety signs (including fire safety signs) is to provide warning and instruction to employees of risks to their health and safety. The signs are intended to remind employees of the actions they should take. Employees should therefore receive adequate information and training on these actions and fully understand the meaning of the safety signs and what they require.

140 Your risk assessment will help you determine the nature and extent of safety signs required. Guidance on this is given in *The Health and Safety (Safety Signs and Signals) Regulations 1996. Guidance on Regulations L64*.¹⁶

141 Safety signs that conform to a recognised standard such as BS EN ISO 7010¹⁷ are acceptable. The signs may be also supplemented with text where you have concluded this to be appropriate.

142 Typically, unless otherwise made obvious, safety signs are commonly posted at the entrances to the locations where flammable liquids are stored, to warn and remind employees of the precautionary measures to be observed.



Figure 4 Example of warning and prohibition signs with supplementary text used at entry points to flammable liquid storage facilities

143 Similarly, unless it is otherwise made obvious (for example, by control of potential ignition sources throughout the site), at the entry points of places that have been classified as hazardous areas (eg gates/doors to storage compounds/buildings/rooms), an appropriate sign should be posted to provide warning to those entering those areas that special precautions are required.



Figure 5 Example of warning sign with supplementary text used at entry points to locations where a potentially explosive atmosphere may exist

Typical storage facilities and arrangements

144 These examples reflect readily achievable good industrial practice. They are intended to help you interpret the requirements discussed previously in the chapter 'Safety measures' and should be read in conjunction with these.

Outdoor storage

145 Outdoor storage areas should be in a well-ventilated area and away from sources of ignition (see Figure 6).

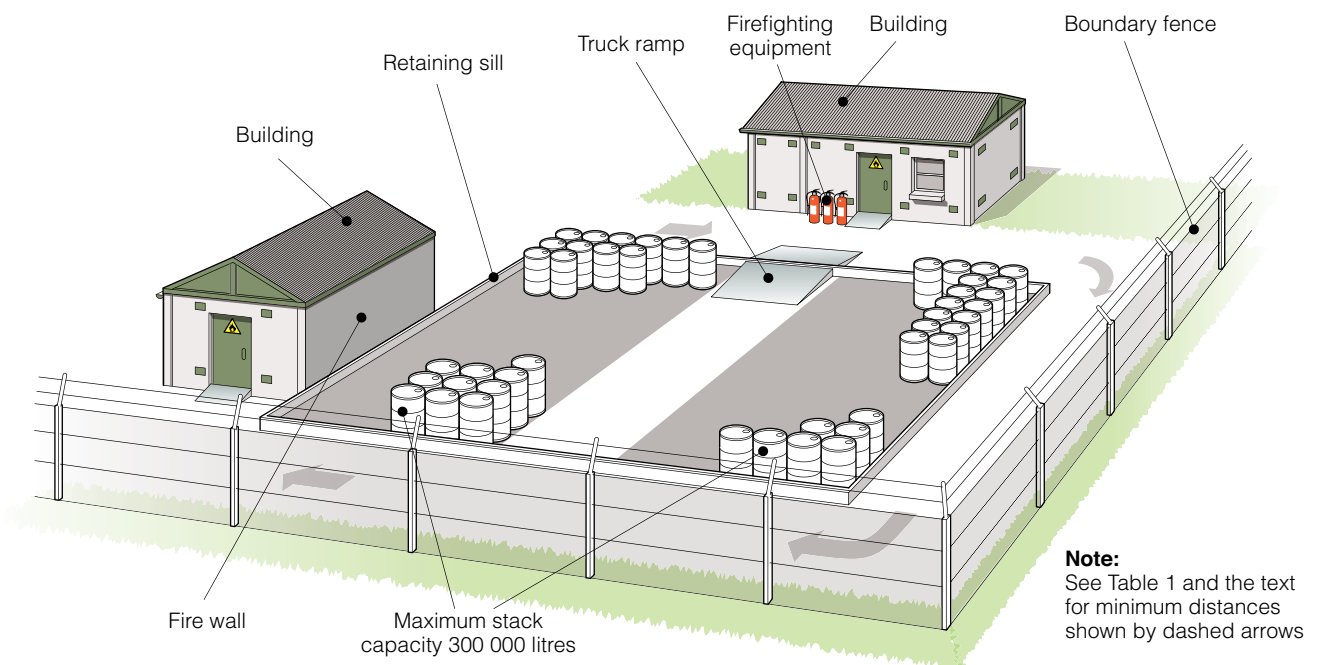

Figure 6 General layout of external storage area

Preventing dangerous accumulations of flammable vapours

146 The storage area should be in an unenclosed and uncongested location at ground level to ensure that any flammable liquid vapours arising from leaks or spillages do not accumulate and can rapidly disperse to safe levels.

147 Ordinarily, storage areas should not be located at elevated positions, such as the roof of a building, or structure. Where this is required (eg for space), particular consideration should be given to design, construction and operation of the facility, including the safe movement of the containers to and from the storage area, to ensure the safety measures minimise the risk of injury to both those working in the storage facility and the other occupants of the building/structure. Particular attention should be given to ensuring the emergency procedures, including general fire precautions (see paragraphs 121–125), fully cover the extended range of incidents that may occur in such circumstance.

Spillage control

148 Outdoor storage areas should be provided with adequate means to control spillages, as detailed in the chapter 'Safety measures'. Where forklift trucks, pallet trucks etc need to access the storage area, ramps may be required to prevent damage to the sill/bund wall and guard against dropping flammable liquid containers.

149 To ensure that the design spillage capacity of the storage facility is not compromised and to guard against corrosion of metal containers in contact with the ground, you should ensure that rainwater does not accumulate in the storage area, for example, by drainage to a remote sump, interceptor or separator. Where a manual valve is used to drain water from the storage area, work procedures should be in place to ensure this is closed following surface water drainage.

Controlling potential ignition sources and hazardous area classification

150 Where flammable liquids are stored at temperatures at or above their flashpoint, or for which such excursion might be anticipated, under DSEAR you must determine the potential extent of the flammable atmosphere that could result from leaks and ensure all potential ignition sources are excluded from such areas (see paragraphs 61–62). The following guidance will help you carrying out the HAC exercise for your workplace. It remains for you to determine that the conditions described are applicable and the type and extent of zones detailed appropriate.

151 During normal operational activities involving the storage and handling of sealed containers, any releases of flammable liquid would be expected to be limited to fugitive emissions and minor leaks. The open and uncongested nature of the storage area should ensure flammable liquid vapours arising from such occurrences do not accumulate and are rapidly dispersed to safe levels. For the purposes of HAC, therefore, the storage area to the height of the sill/bund wall can be treated as zone 2. Individual containers should be assumed to have a nominal zone 2 around them, which for simplicity may be taken as equivalent to that at the 'sealed' container openings (ie with caps in place) of 0.1 m. Drainage channels around and from the storage area (including remote sump, interceptor or separator and any other below ground-level feature that flammable liquids might drain to) should be treated as zone 1.

152 Appropriate controls should also be in place to exclude or prevent ignition sources that could compromise the safety of the storage facility, or ignite a large flammable liquid spillage into the bunded area should this occur, for example, as a result of container failure and/or accident. Such controls should be applied within the recommended minimum separation distances shown in Table 1.

153 Where the presence of the potential ignition source is related to an occasional work activity, the work activity should be subject to a PTW procedure. This includes work activities incidental to the main work activities on site, eg the use of lawnmowers and strimmers to control vegetation.

154 Where the potential ignition source is necessarily present within the separation distances during normal work activities, arrangements should be in place for this to be safely isolated in the event of a substantial release of flammable liquid. Whether this is by manual intervention or requires executive action through an electronic control system is for you to determine based on the risk of harm an incident would present to your employees and others, as determined by your risk assessment. For example, the use of flammable gas detectors to isolate/shut down plant and equipment may be appropriate, such as 'added safety/increased protection' features taken on a forklift truck to reduce the probability of ignition in the event of a flammable liquid spillage.

Separation

155 The storage area should be located sufficient distance from the boundary of the premises and other plant, buildings and structures within the premises to guard against:

- a fire outside the boundary, or involving other plant, buildings or structures within the premises, compromising the integrity of the stored flammable liquid containers and potentially resulting in a fire in the storage area; and
- a fire within the storage area threatening the safety of people both within or outside the premises.

156 The recommended minimum separation distances shown in Table 1 are dependant on the quantity of flammable liquid stored. The distances are based on widely accepted industry practice. Although these distances may not provide complete fire protection to prevent other parts of the premises from being affected by a fire in the storage area, or prevent fire causing damage beyond the boundary, they should provide time to implement emergency procedures (see chapter 'Emergency procedures') and enable people to evacuate to a place of safety. Similarly the separation distances are intended to provide for time for people to safely evacuate the flammable liquid storage area and implement emergency procedures as appropriate to protect the stored flammable liquid containers from a fire in another part of the premises or off site.

157 Where these separation distances cannot be realised, additional protective measures, typically a fire wall, may be used to justify a reduction in the minimum separation distances given in Table 1 (see paragraphs 161–168).

158 Your risk assessment may also highlight particular issues at your workplace to indicate that the minimum separation distances are inadequate; for example, concerning the estimated time for attendance by the emergency services to provide help; the availability of adequate water supply; the extent and nature of process plant; and the closeness of vulnerable populations. An increase of the minimum separation distances quoted in Table 1 may be appropriate to delay and possibly prevent an incident escalating to threaten the safety of people both within and outside the premises.

159 Alternatively, you may take additional protective measures instead of increasing the separation distance. Additional protective measures can either be active (such as water deluge systems, or monitors) or passive (such as a fire wall).

Table 1 Minimum separation distances

Quantity stored (litres)	Distance from occupied building, boundary, process unit, flammable liquid storage tank or ignition source (metres)
Up to 1 000	2
1 000 – 100 000	4
Above 100 000	7.5

Notes:

- The maximum stack size should be 300 000 litres, with at least 4 metres between stacks.
- Containers should not be stored within the bund of a fixed flammable liquid storage tank or within 1 metre of the tank bund wall.

160 You should ensure that the separation distances provided are not compromised by storing or permitting accumulation of combustible materials in the free space between the storage area and boundary, other plant, buildings and structures etc. Undergrowth and other vegetation should be properly managed to prevent it becoming a fire risk or interfering with the free movement of air. The area within 1 metre of the sill or bund should be kept substantially free of any vegetation. You should not use burning or oxidising agent-based weedkillers (such as sodium chlorate) to control the vegetation. Dead vegetation should be promptly removed.

Separation by a fire wall

161 Fire walls are a physical barrier of fire-resisting construction that may be a free-standing structure in the open air, or form part of a bund wall, boundary wall or building wall. The fire wall should be at least as high as the container stack, with a minimum height of 2 metres. The wall should also be long enough to ensure that the horizontal distance from the defined flammable liquid storage area (the edge of the bund) around the wall to any building, boundary, source of ignition etc is at least the appropriate distance quoted in Table 1. This provides an equivalent distance for dispersal of vapours from any flammable liquid spillages or leaks in the storage area (see Figures 7–9).

162 Aside from the relaxation provided for wing walls as shown in Figure 8, to enable the free movement of air and rapid dispersal of any flammable liquid vapours, fire walls should not be provided on more than two sides of the storage area and normally on one side only.

163 To ensure stable stacking and enable any leaking flammable liquid containers to be readily identified, the containers should ideally not be stacked against the wall, unless this is in a properly designed and installed racking system.

164 The fire safety performance of a fire wall is specified in terms of:

- resistance to fire; and
- reaction to fire.

165 The definitions and technical specifications for these terms are given in Appendix 1, along with other additional requirements for physical barriers of fire-resisting construction. These include the requirement that the construction should be sufficiently robust not to be damaged by foreseeable impacts; and that it is suitably resilient to ensure where contact with the flammable liquid may occur, the fire wall's effectiveness is not adversely affected.

166 Fire walls should be imperforate and should provide a minimum of 30 minutes fire resistance in respect of integrity, insulation and, where applicable, load-bearing capacity.

167 Where the wall separates vulnerable populations from the stored flammable liquids, the fire resistance should be a minimum of 60 minutes. Vulnerable populations include those in schools, hospitals, care homes and other residential accommodation.

168 The materials used in the construction of the wall should have a 'minimal risk' in respect of their reaction to fire. Concrete, masonry or brick construction is preferred.

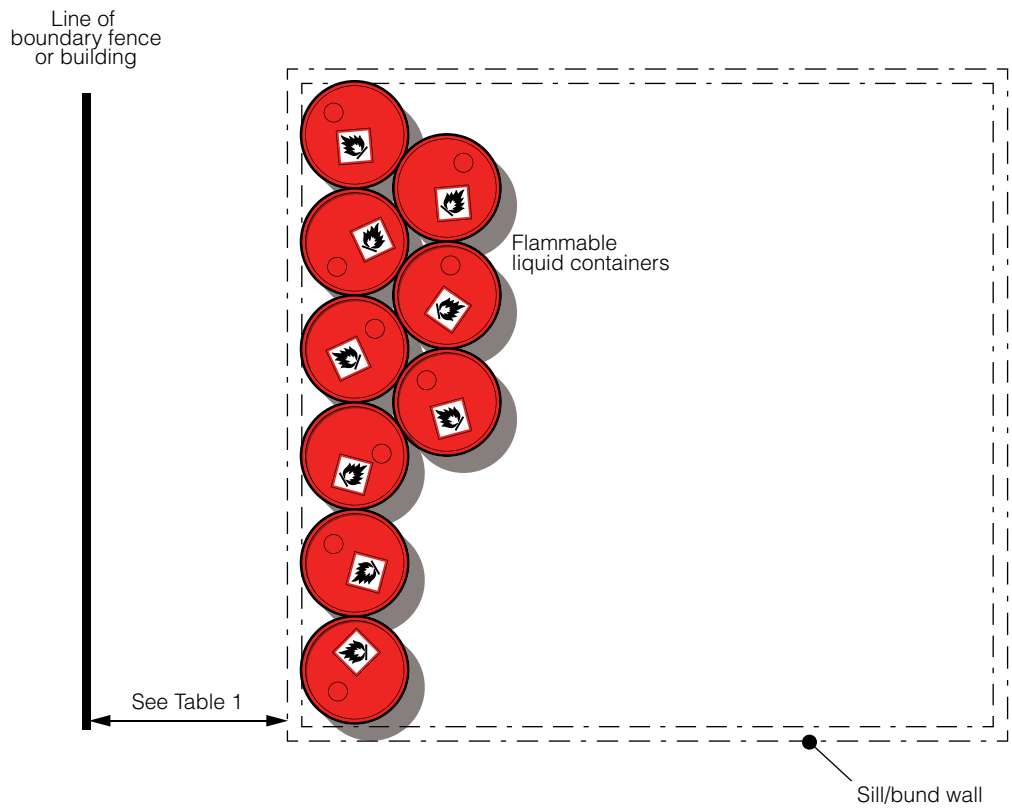

Figure 7 Separation distance without a fire wall (viewed from above)

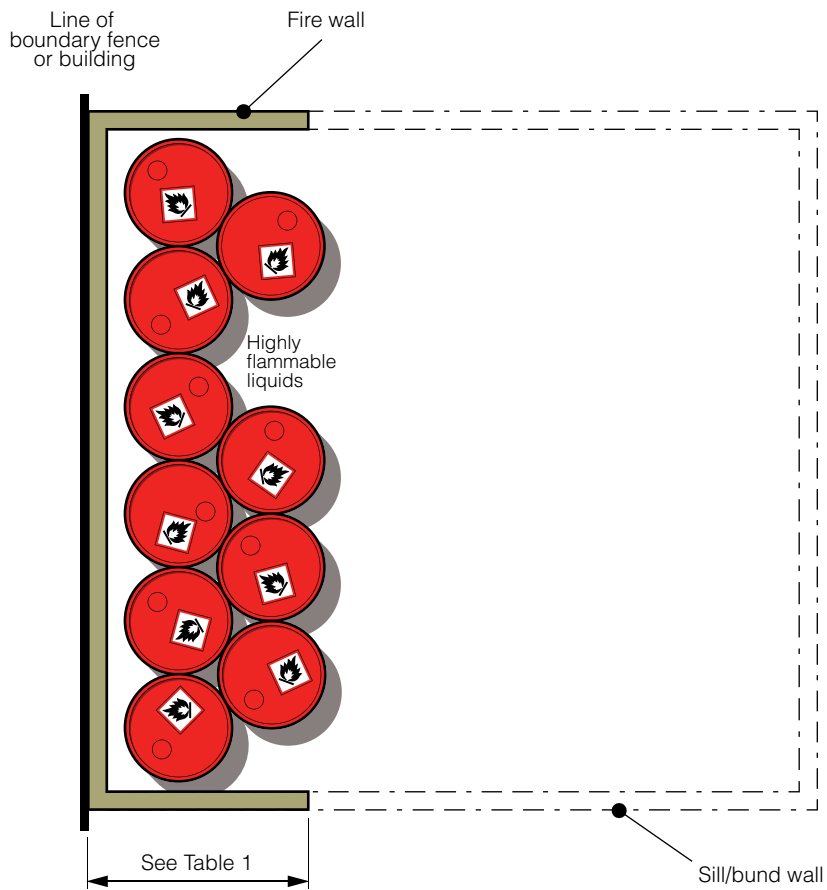

Figure 8 Separation distance with a fire wall (viewed from above)

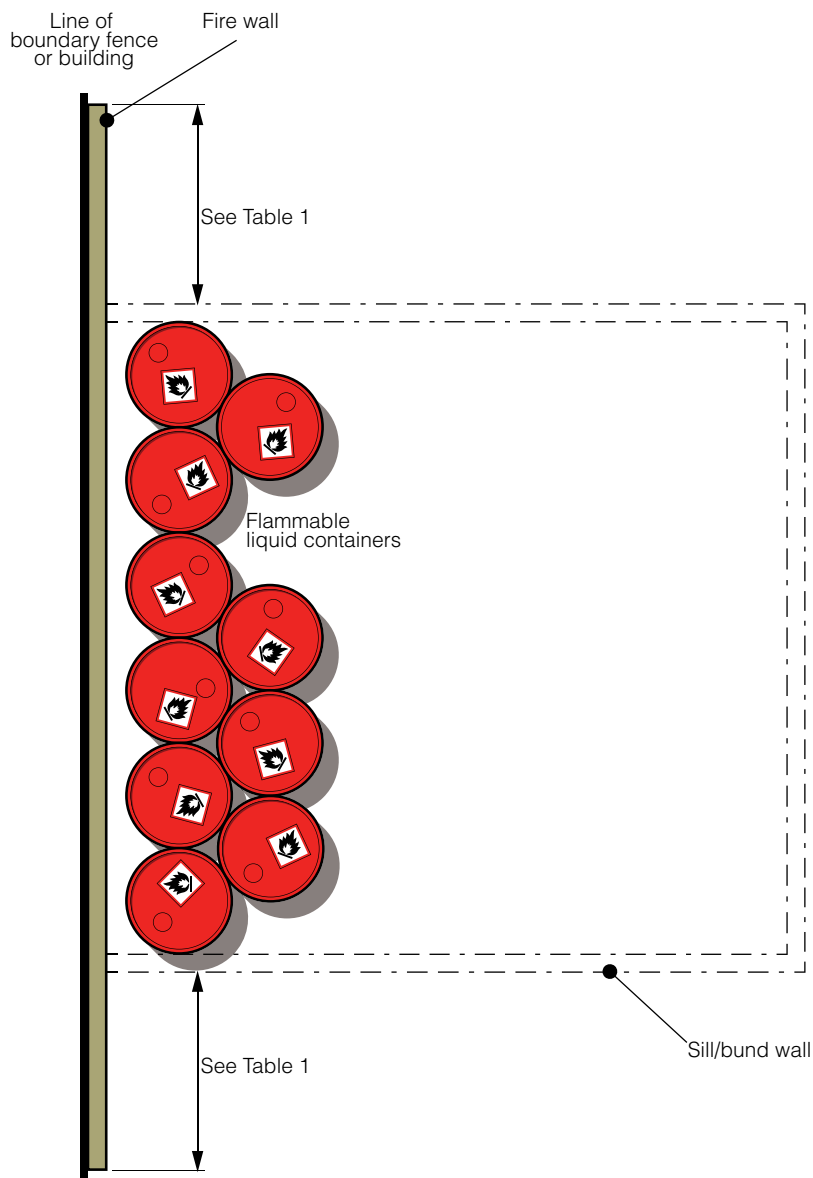

Figure 9 Separation distance with a fire wall – alternative arrangement (viewed from above)

Storage in dedicated (separate) buildings

Ventilation

169 Adequate ventilation is required in buildings used for storing flammable liquids to ensure the safe dispersal of flammable vapours that may arise from any small releases or leaks from the containers and prevent their accumulation. The ventilation arrangements need to take into account that flammable vapours are heavier than air, and ensure adequate air movement at high and low levels.

170 The simplest method of providing ventilation is through natural ventilation. This may be achieved by fixed, permanent openings (such as airbricks or louvres etc) at high and low levels in the external walls of the building to the outside air. Ideally, the openings should be located on at least two opposite walls to allow a cross-flow ventilation of the building to be induced by wind forces. Additionally location of the openings at high and low level will encourage air circulation by thermal currents (see Figure 10). Where this can be achieved, the openings should have a total free area

equivalent to at least 1% of the total area of the walls and roof of the store. Where openings cannot be provided to facilitate cross-flow ventilation, a larger free area of ventilation openings may be required to ensure the building is adequately ventilated.

171 The degree of natural ventilation will depend on a variety of environmental factors. Where the building is in an obstructed or sheltered location, a total free area of openings greater than 1% of the total area of the walls and roof may be required. BS 5925¹⁸ gives advice on ventilation design principles for buildings. In cases of doubt, measurements to determine the actual ventilation of the building can be undertaken. Where required, a competent ventilation engineer should be able to advise you.

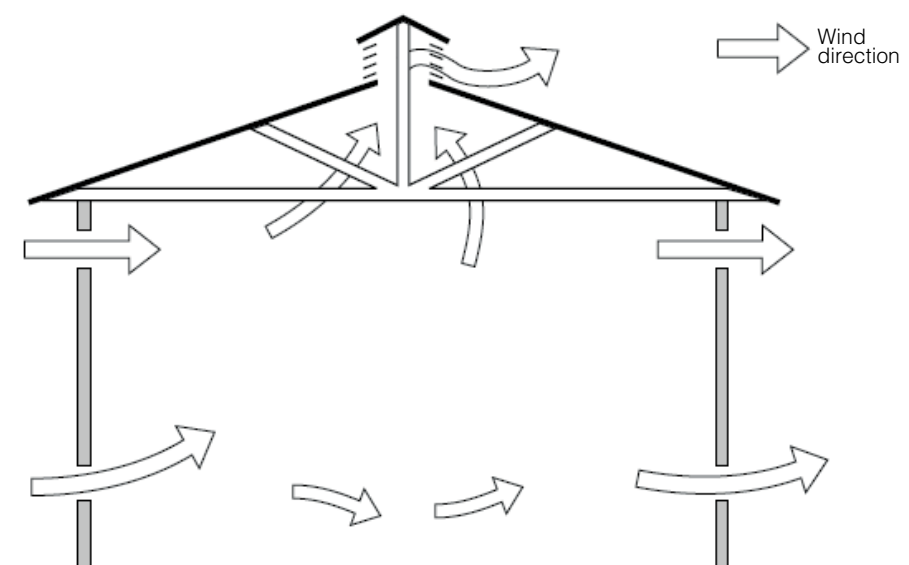

Figure 10 Roof and wall vents together give good natural ventilation

172 Ventilation openings should not be located in internal walls, or below the level of the containment sill/bund provided. Nor should ventilation openings be installed in any partitions that serve as physical barriers of fire-resisting construction (see Appendix 1). Where this is unavoidable, such openings should self-close and seal in a fire situation to maintain fire integrity and insulation requirements for the partition. You should seek the advice of a competent fire engineer if this option is considered.

173 You should ensure that the ventilation openings are not obstructed by, for example, storage or accumulation of materials against the outside wall, or how the flammable liquid containers are stored inside the building. The openings should be periodically inspected and maintained to ensure they remain free from blockages.

174 Alternative to natural ventilation, mechanical exhaust ventilation can be used. This may also be required if the provision of adequate natural ventilation is not possible, for example, where an insufficient area and/or distribution of ventilation openings can be provided. Further guidance on providing mechanical exhaust ventilation systems is given in Appendix 2.

Control of spillages

175 The building should have adequate means to prevent the uncontrolled spread of any spillages or leaks of flammable liquid out of the building (see paragraphs 55–56). Floors and walls to the height intended to serve as a sill should provide a

bunded area that is impervious and resistant to the flammable liquids stored (through use of appropriate construction materials and treatment). The sill should extend across the door openings, unless the required bund capacity can be achieved by other means, for example, by sloping the floor away from door(s). To avoid compromising natural ventilation, the sill height should typically not exceed 150 mm.

176 Where a sill is provided across the door opening and forklift trucks, pallet trucks etc access the storage area, ramps may be required to prevent damage to sill/bund wall and guard against dropping the flammable liquid containers.

Controlling potential ignition sources and hazardous area classification

177 Where flammable liquids are stored at temperatures at or above their flashpoint, or for which such excursion might be anticipated, you are required under DSEAR to determine the potential extent of the flammable atmosphere that could result from leaks and ensure all potential ignition sources are excluded from such areas (see paragraphs 61–62). The following guidance will help you carry out the HAC exercise for your workplace. It remains for you to determine that the conditions described are applicable and the type and extent of zones detailed appropriate.

178 Ventilation conditions will have a significant influence on the extent of the zones. For buildings reliant on natural ventilation, given the variation that may be expected, it is appropriate to consider all of the building to be zone 2. If the building contains drainage channels and/or sump, it should be treated as zone 1.

179 Where the building can be shown to be well and effectively ventilated, a reduction in the extent of the zone may be appropriate. For example, in well-ventilated buildings, zone 2 might be determined to extend a finite distance, such as 2 m, above the highest container, with the space above this deemed non-hazardous, ie not zoned in accordance with the HAC process. However, you should still have appropriate controls in place to exclude or prevent ignition sources that could compromise the safety of the storage facility, or ignite a large flammable liquid spillage into the bunded area should this occur as a result of container failure and/or accident.

180 Similarly, such controls should be applied within the recommended minimum separation distances given in Table 1 from those parts of the building that are not a physical barrier of fire-resisting construction (see below and Appendix 1).

Separation

181 The building (aside from doors and windows together with their associated frames) should be constructed from materials that are categorised as having a minimal or low reaction to fire (see Appendix 1). To guard against building collapse in the event of an explosion, construction of the roof of the building, wall or substantial section of this from lightweight materials is recommended to provide explosion relief. The minimal or low reaction to fire requirement is waived in respect of the explosion relief construction, though preference should be given to choosing materials that have the lowest reaction to fire category.

182 Ideally, the building should be located so that the distance between its outside wall and any other building, boundary etc is at least that detailed in Table 1 for the quantity of flammable liquid stored in the building. Where this is not achieved, the building wall, or that part within the separation distance, should be to the standard of a fire wall (see Appendix 1). In this circumstance, doors to the building are

permitted, but those within the separation distances detailed in Table 1 should provide a minimum of 30 minutes' fire resistance and be self-closing (see Appendix 1). Ideally, doors should not be located in a building fire wall that faces the boundary, and should be avoided if there are vulnerable populations on the other side of the boundary.

183 You should ensure that sufficient openings can be provided in the remaining walls or parts of the walls to provide adequate natural ventilation. Where this cannot be achieved, one of the following measures may alternatively be used:

- except for fire walls on the boundary, ventilation openings are permitted provided they automatically close in the event of fire (see paragraph 172);
- extend fire walls from the building to achieve the required separation distance;
- install mechanical exhaust ventilation (see Appendix 2).

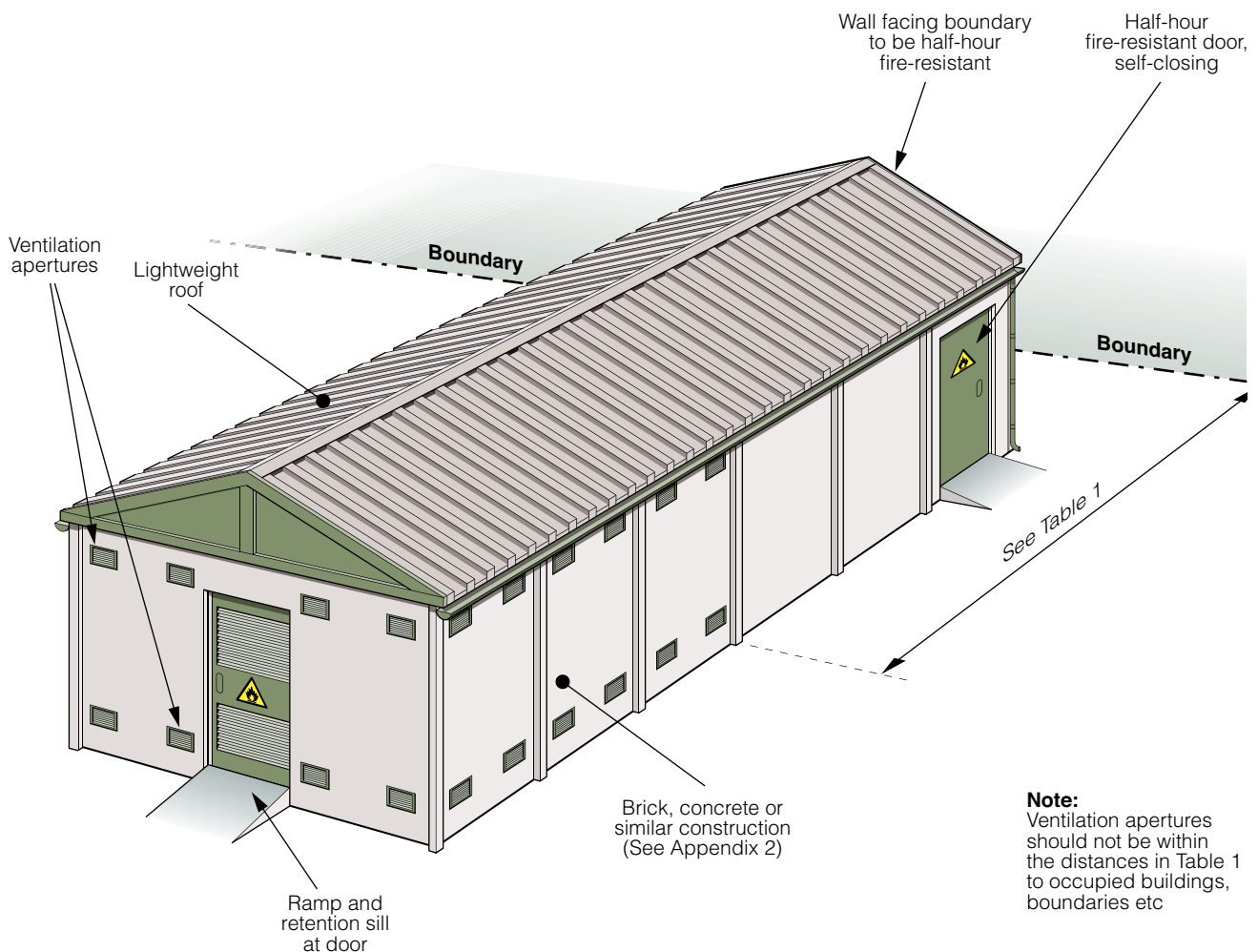

Figure 11 Example of a storage building (partially of fire-resisting construction) illustrating required features

Storage in storerooms (within other buildings)

184 The precautions for storing containers in storerooms that form part of a building used for other purposes are essentially a variation of the measures discussed previously in paragraphs 169–174.

185 Storerooms should not be sited below ground, where natural ventilation will be severely restricted. If a flammable liquid storeroom is to be located in a multi-storey building, you should ensure adequate general fire precautions (see paragraphs 121–125) are provided. In particular, the means of escape from any part of the building should not be jeopardised by a fire involving the flammable liquid containers in the storeroom, or (should a fire occur) during the movement of containers through the building, into and out of the storeroom.

Ventilation

186 Adequate ventilation is required for rooms used for storing lower flashpoint flammable liquids to ensure the safe dispersal of flammable vapours that may arise from any small releases or leaks from the flammable liquid containers and prevent their accumulation. The ventilation arrangements need to take into account that the flammable vapours are heavier than air, and ensure adequate air movement at high and low levels.

187 The simplest method of providing ventilation is through natural ventilation. This may be achieved by fixed, permanent openings (such as airbricks or louvres etc) at high and low levels in the external walls of the building to the outside air. The number of external walls available to install ventilation openings in may be limited. In such circumstances, an increase in the total free area of the ventilation openings in excess of the minimum of at least 1% of the total area of the walls (external and internal) and roof/ceiling of the store may be required.

188 Further guidance is available in BS 5925. In cases of doubt, measurements to determine the actual ventilation of the room can be undertaken. Where required, a competent ventilation engineer should be able to advise.

189 Ventilation openings should not be located in internal walls, or below the level of the containment sill/bund provided.

190 You should ensure that the ventilation openings are not obstructed by, for example, storage or accumulation of materials against the outside wall, or the manner the flammable liquid containers are stored inside the building. The openings should be periodically inspected and maintained to ensure they remain free from blockages.

191 Alternative to natural ventilation, mechanical exhaust ventilation can be used. This may also be required if the provision of adequate natural ventilation is not possible, for example, due to the aspect (length/width) ratio of the room and/or insufficient area available on an external wall to install adequate ventilation openings. Further guidance on providing mechanical exhaust ventilation systems is given in Appendix 2.

Control of spillages

192 The storeroom should have adequate means to prevent the uncontrolled spread of any spillages or leaks of flammable liquid out of the room (see paragraphs 55–56). Floors and walls to the height intended to serve as a sill should provide a banded area that is impervious and resistant to the flammable liquids stored (through use of appropriate construction materials and treatment). The sill should extend across the door openings, unless the required bund capacity can be achieved by other means, for example, by sloping the floor away from door(s). To avoid compromising the effectiveness of the natural ventilation, the sill height should typically not exceed 150 mm.

193 Where access is required for wheeled trolleys etc, ramps may be required over the sill to prevent damage to the sill/bund wall and guard against dropping the flammable liquid containers.

Controlling potential ignition sources and hazardous area classification

194 Where flammable liquids are stored at temperatures at or above their flashpoint, or for which such excursion might be anticipated, you are required under DSEAR to determine the potential extent of the flammable atmosphere that could result from leaks and ensure all potential ignition sources are excluded from such areas (see paragraphs 61–62). The following guidance will help you carry out the HAC exercise for your workplace. It remains for you to determine that the conditions described are applicable and the type and extent of zones detailed appropriate.

195 Ventilation conditions will have a significant influence on the extent of the zones. For storerooms reliant on natural ventilation, given the variation that may be expected, it is appropriate to consider the entire room to be zone 2. If the room contains drainage channels and/or sump, it should be treated as zone 1.

196 Where the room can be shown to be well and effectively ventilated, a reduction in the extent of the zone may be appropriate. However, you should still ensure that appropriate controls are in place to exclude or prevent ignition sources that could compromise the safety of the storage facility, or ignite a large flammable liquid spillage into the bunded area should this occur as a result of container failure and/or accident.

197 Similarly, such controls should be applied within the recommended minimum separation distances given in Table 1 from those partitions (including walls, ceiling and floor as relevant) of the storeroom that are not a physical barrier of fire-resisting construction (see below and Appendix 1).

Separation

198 All internal partitions of the storeroom – ie every wall (including any door), floor (other than a floor immediately above the ground), ceiling and its associated floor (other than the top or ceiling of a single storey building or of a top floor room) – should be a physical barrier of fire-resisting construction (see Appendix 1). They should provide a minimum of 30-minutes fire resistance in respect of integrity, insulation and, where applicable, load-bearing capacity.

199 The construction of the internal partitions should be sufficiently robust that their integrity/fire resistance is not compromised by foreseeable impacts, and that the partitions (including surface treatments) are suitably resilient to ensure where contact with the flammable liquid may occur, their effectiveness is not adversely affected.

200 You should ensure that the junction between each part of a fire-resisting physical barrier is sufficiently bonded or fire-stopped to ensure that fire resistance is not compromised. In particular, where there is a common ceiling/roof structure between the storeroom and the rest of the building, ensure that the compartmentation of the storeroom from the rest of the building is complete to prevent the fire spreading to other parts of the building through the roof space. This can be achieved by providing 30-minute fire-resisting partitions either horizontally between the ceiling of the store and the roof space, or in the case of single-storey buildings, vertically in the roof space between the store and the rest of the building.

201 Ideally such situations are to be avoided, but where the storeroom is within a building that also contains residential accommodation, the partition between the two should provide a minimum of 60-minutes fire resistance, with no connecting doors or direct access between the two premises. It is also recommended that automatic fire detection is installed in the flammable liquid store linked to audible alarms in the residential area.

External walls as physical barriers of fire-resisting construction

202 Given the limited number of external walls that a storeroom is likely to have, it is unlikely that a storeroom will be suitably safely located if it requires the external wall(s) to be physical barriers of fire-resisting construction. This is because of the requirement for adequate ventilation, and potential requirement for a wall to be constructed from lightweight materials to serve as explosion relief. You should ensure that adequate safety is provided if external walls are required as physical barriers of fire-resisting construction.

203 In such circumstances, as well as the likely reliance on mechanical exhaust ventilation to ventilate the storeroom (see Appendix 2), mechanical exhaust ventilation may also be required as an alternative to explosion relief. The mechanical exhaust ventilation should be designed to achieve rapid dilution of the flammable vapours to a safe level that may result from the maximum leak envisaged, for example the failure of the largest flammable liquid container handled. While the principles of Appendix 2 are still applicable, the detailed design of such ventilation systems is outside the scope of this guidance. It is recommended that the design, installation and commissioning is undertaken by a suitably qualified engineer after a sufficient technical evaluation and confirmation of the incident scenarios that the mechanical exhaust ventilation system is to be able to deal with.

Doors and glazing

204 No glazed area should be installed in any physical barrier of fire-resisting construction. However, in the case of a door, a glazed viewing panel may be installed provided it does not exceed an area of 20% of the door. Any glazing should still satisfy the integrity requirements. This can be achieved by using Georgian wired glass or a proprietary fire-resisting glazing panel.

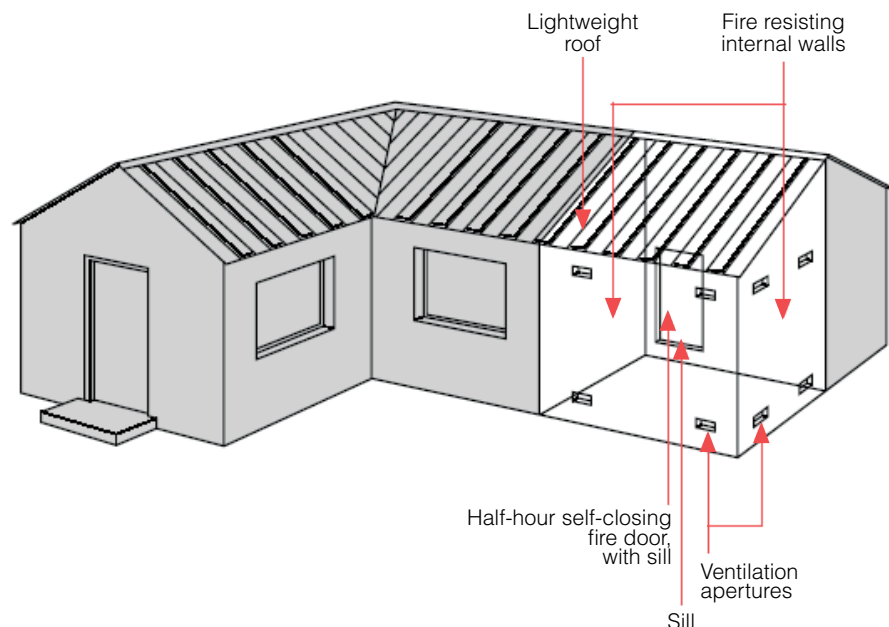

Figure 12 Example of a storeroom in a building illustrating required features

205 Any door in a physical barrier of fire resisting construction should be self-closing from any position.

Construction materials

206 The materials used in the construction of the storeroom (other than doors and windows together with their associated frames, and any provision made for explosion relief) should as a minimum, have a 'low risk' in respect of their reaction to fire (see Appendix 1). While the reaction to fire requirement is waived in respect of the explosion relief construction, preference should be given to choosing materials that have the lowest reaction to fire category.

Storage in process areas, workrooms, laboratories and similar working areas

207 Many work activities will require the convenient availability of flammable liquids and/or flammable liquid-based products. To facilitate this, a limited quantity in suitable closed vessels may be stored in suitable cabinets or bins of fire-resisting construction that are designed to retain spills (capacity should be 110% volume of the largest vessel normally stored in it).

208 Under DSEAR you must determine the potential extent of the flammable atmosphere that could result from leaks and ensure all potential ignition sources are excluded from such areas (see paragraphs 59–62). This requirement extends to cabinets, bins etc used to store lower flashpoint flammable liquids. For the storage of such flammable liquids, the whole of the inside of the cabinet, bin etc should normally be taken to be zone 2.

209 The cabinet, bin etc should be located in designated well-ventilated areas that are:

- away from the immediate processing area where possible; and
- do not jeopardise the means of escape from process and other areas.

210 The flammable liquids should be stored separately from other dangerous substances that may increase the risk of fire or compromise the integrity of the container or cabinet/bin, such as energetic substances, oxidizers and corrosive materials. Sometimes these other dangerous substances may be flammable liquids in their own right or held in a flammable liquid. However, it is still inappropriate to store these in the same cabinets or bins with other flammable liquids.

Storage quantities

211 The recommended maximum quantities that may be stored in cabinets and bins are:

- no more than 50 litres for extremely, highly flammable and those flammable liquids with a flashpoint below the maximum ambient temperature of the workroom/working area;
- no more than 250 litres for other flammable liquids with a higher flashpoint of up to 60 °C.

212 These quantities are intended to be viewed as recommended maxima representing industry safe practice, rather than absolute limits. There is some flexibility with these limits, where for example the design of modern day buildings and the pattern of work can make it difficult to work within these limits for example,

in large or open-plan workrooms/working areas. Where you propose to store quantities in excess of the recommended maxima, you should consider recording your justification in your risk assessment, which should take into account:

- the properties of the materials to be stored or handled in the process areas, workrooms, laboratories and similar working areas (for mixed storage the worst-case situation should be applied, ie all materials in the storage cupboard or bin should be considered as being the same material as the one that has the lowest flashpoint);
- the size of the process area etc and the number of people working in it;
- the amount of flammable liquids being handled in the process area etc and the quantities of liquid that may be accidentally released or spilled;
- ignition sources in the process area etc and potential fire spread in the event of an ignition:
- exhaust ventilation provision to the process area etc and/or the storage cupboard or bin;
- the fire-resisting performance of the storage cupboard or bin;
- the arrangements for closing the cupboard or bin doors/lid in the event of a fire;
- means of escape from the process area etc.

Fire-resisting cupboards and bins

213 The objective, in the event of an incident, is to ensure that people can safely escape from process and other areas. The purpose of storing dangerous substances in cupboards and bins of appropriate construction and design is to provide a physical barrier to defer their involvement in a fire. If the dangerous substances become involved, limiting the passage of fire and hot gas should allow sufficient time for safe evacuation and for the implementation of your immediate emergency procedures.

214 Appendix 1 details the performance requirements for fire-resisting cupboards and bins. These do not specify an absolute test or standard for the cupboard or bin itself, rather they relate to nominal construction principles. Namely that:

- the materials used to form the sides, top, bottom, door(s) and lid are capable of providing the required fire resistance (ie 30 minutes' integrity) and reaction to fire (ie minimal risk);
- the joints between the sides, top and bottom of cupboards and bins should be free from openings or gaps;
- the lid/doors should be close fitting against the frame of the bin/cupboard, such that there is a nominal overlap between the frame and lid/doors in their closed position;
- the supports and fastenings should be of a material with a melting point greater than 750 °C.

215 These criteria are the minimum performance requirements for compliance with current legislation. However, there are a number of more demanding standards and design specifications, which refer to the fire performance of the complete cabinet structure, including:

- BS EN 14470-1;¹⁹
- Factory Mutual, Underwriters Laboratories standards; and
- NFPA 30 *Flammable and combustible liquids code*.²⁰

216 Where standards go beyond the minimum requirements of UK health and safety legislation, it should be emphasised that their implementation in the UK is not

a legal requirement. However, for quantities in excess of the recommended maxima employers/dutyholders may find the use of cabinets with enhanced fire performance can help them demonstrate that the measures they are taking are sufficient to reduce the risks so far as is reasonably practicable.

217 It is your responsibility to ensure that cabinets to any particular standard or design specification meet the minimum legal requirements. Equally, the use of cabinets with enhanced fire performance should not be seen as a substitute for providing dedicated storerooms and outdoor storage areas for the safekeeping of containers which are nominally empty or are not needed for current work.

218 The construction of the cabinet, bin etc, should be sufficiently robust that its integrity/fire resistance is not compromised by foreseeable impacts; and that the materials it is constructed from, including surface treatments are suitably resilient to ensure where contact with the flammable liquid may occur, its effectiveness to provide safe storage of flammable liquids is not adversely affected.

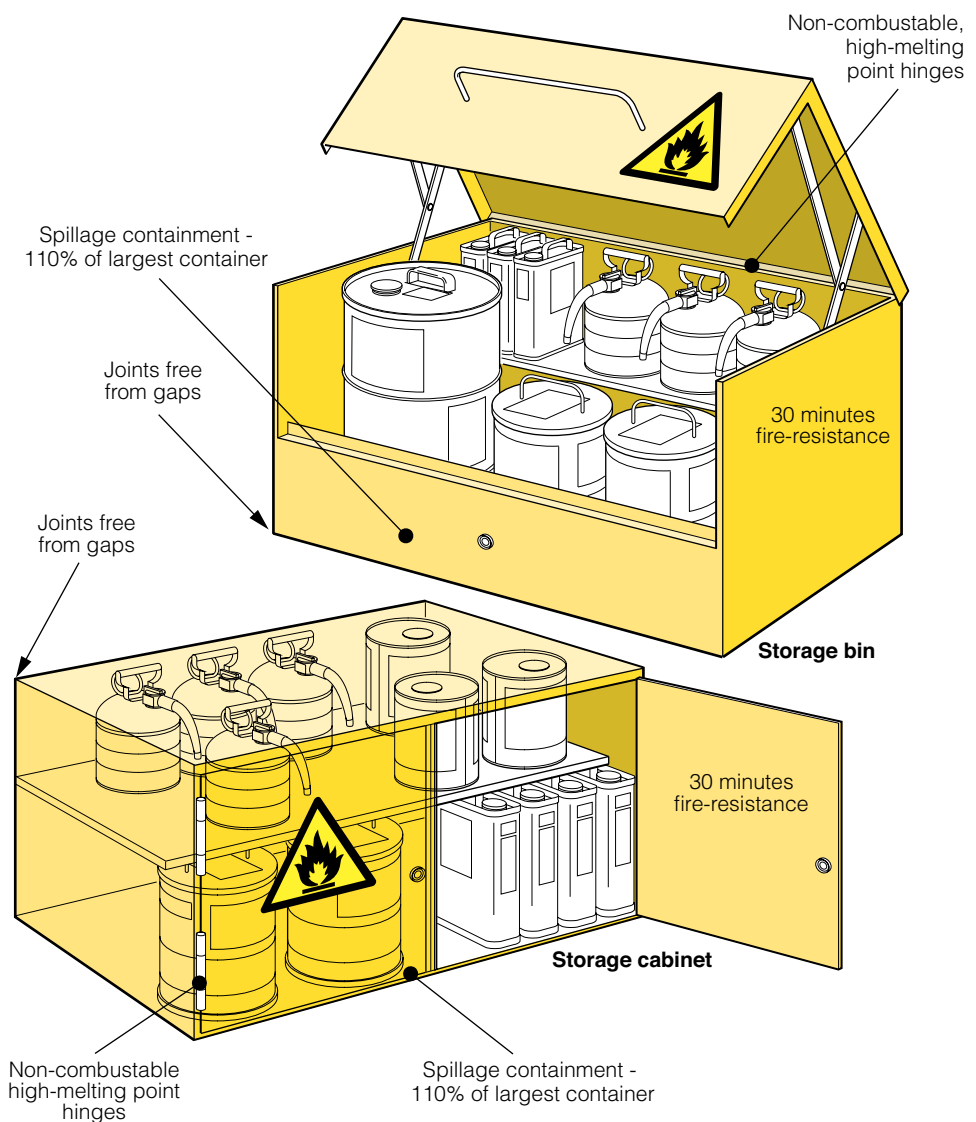

Figure 13 Example of storage cabinet and bin illustrating required features

Procedures and record keeping

219 To help minimise the risk from fire or explosion involving the flammable liquid containers in the process area etc, work procedures should be developed and followed to ensure the containers are promptly returned to the cabinet, bin etc when not required.

220 Keeping a record of the contents in each cabinet, bin etc will provide a ready means to check that the maximum storage quantities are not exceeded. It will also enable you to identify flammable liquids that are rarely used and can be removed to a dedicated flammable liquid store room/outdoor storage area, and those flammable liquids that are no longer used and can be safely disposed of.

Storage of finished products

221 Finished products which are lower flashpoint flammable liquids should be stored in a properly designed storage facility as previously described, ie 1 Outdoor storage, 2 Dedicated building, or 3 Storeroom. However, finished products may be stored temporarily in loading bays if they are awaiting imminent despatch, subject to the following conditions:

- the loading bay is not part of a workroom; and
- during the period the finished products are stored, work activities in the loading bay are carefully controlled to prevent incident.

222 Where flammable liquids are stored at temperatures at or above their flashpoint, or where such excursion might be anticipated, under DSEAR you must determine the potential extent of the flammable atmosphere that could result from leaks and ensure all potential ignition sources are excluded from such areas (paragraphs 59–62). This guidance will help you in this exercise. However, it remains for you to determine that the conditions are appropriate for the type and extent of zones detailed to be adopted.

223 Where the flammable liquid-based finished products are in containers of not more than 0.5 litre nominal capacity, the extent of accidental spillage from a single container would be expected to be relatively limited. It is therefore permissible for such containers to be kept in a general storage facility with other materials at the premises of the manufacturer, distributor or retailer. However, appropriate precautions should still be taken to reduce the risk of fire and explosion. These include:

- only sealed/unopened containers are stored;
- the store is separated from production areas by partitions of appropriate fire-resisting construction (see Appendix 1);
- incompatible materials, such as peroxides and other oxidising agents, are not kept in the store;
- combustible packaging materials, which are not in immediate use, are not kept in the store;
- adequate ventilation is provided, ideally to the standard recommended for storerooms (see paragraphs 186–191);
- sampling or dispensing into other containers is not carried out in the store;
- the containers are not sited above electrical fittings (including lighting) or heating appliances, and should be at least 0.5 m horizontally from and vertically below these unless they are ATEX certified, unless the HAC indicates otherwise (see paragraphs 57–66);
- there is strict control of the plant and equipment that can be taken into the store;
- smoking and smoking equipment is prohibited.

Temporary storage

224 Where it is necessary to keep containers temporarily outside of the designed storage area to aid production or processing scheduling (for example, where these may be required in or near process plant areas for use during that day or shift), appropriate precautions should be taken to ensure that the risks are properly controlled.

225 Careful attention should be given to ensuring:

- the containers are properly closed and labelled;
- the containers are not stored where they might obstruct or interfere with the means of escape from fire (see paragraphs 121–126). Ensure they are kept away from fire exits and external stairways that are fire escapes;
- appropriate precautions are provided to contain leaks or direct these to a safe place;
- appropriate controls are in place to exclude or prevent ignition sources should spillage of flammable liquid occur;
- the temporary storage is time limited, typically no longer than a shift or working day, at the end of which unused containers and those part-used and nominally empty are returned to the permanent storage facility.

Storage and display at retail premises

226 In a factory or other workplace the people present will be aware of the hazards that the flammable liquids pose and will be trained in the emergency procedures to take in the event of incident. However, at retail premises, members of the public, including children, will generally have unrestricted access to significant parts of the premises.

227 The risks of fire and explosion associated with the storage of flammable liquids can be reduced if the amount on display in areas to which the public have access is kept to a minimum, consistent with the needs of the business. For example, dummy or empty containers might be used for display in substitution for full containers.

228 Keeping additional stocks away from the sales area to which the public have access will reduce the risk of an incident and its size. The additional stock could be kept in a storage area, building, room or cabinet that is designed to the standards in this book or equivalent. Access to the storage area should be limited to authorised personnel.

229 Where flammable liquid-based products are necessarily displayed in those parts of the premises to which the public have access, appropriate measures to control the risk should be taken. The following sections for large retail outlet and small retail outlet/shop provide guidance on these.

230 Some flammable liquids, particularly for paint mixing etc, are stored within special units which include facilities for weighing, dispensing and mixing. These units should be sited in a well-ventilated room or area which is preferably used only for the purpose of paint mixing.

231 Where flammable liquids are stored at temperatures at or above their flashpoint, or for which such excursion might be anticipated, the requirement remains under DSEAR for you to determine the potential extent of the flammable atmosphere that could result from leaks and ensure all potential ignition sources are excluded from such areas (see previous discussion of HAC in paragraphs 59–62).

The guidance provided is to assist you in this exercise. However, it remains for you to determine that the conditions are appropriate for the type and extent of zones detailed to be adopted.

Storage in a large retail outlet

232 Large retail outlets catering for both the trade and the public are common. Such premises are typically large, single-storey, open-plan warehouse buildings with high roofs. The goods are generally stacked on pallets on open racking, with the majority of the stock held in parts of the building to which customers have access.

233 Flammable liquid-based products should preferably be stored separately, as discussed above for the 'Storage at retail premises'. However, where this cannot be realised, the following precautions (detailed in paragraphs 234–238) are relevant for those flammable liquid-based products necessarily stored in the parts of the building to which the public have access.

234 Careful consideration should be given to where the products are sited. The location should not restrict the width of aisles or impede any means of escape in the event of incident, and should be in a position that can be easily monitored. For example, can the flammable liquid-based products be stored:

- in an outdoor retail area, such as the gardening department (with weather protection as required); or
- adjacent to non-combustible stock, such as building materials?

235 The flammable liquid-based products should not be sited above electrical fittings (including lighting) or heating appliances, and should be at least 0.5 m horizontally from and vertically below these unless they are ATEX certified, unless the HAC indicates otherwise (see paragraphs 57–66).

236 Many spillages occur when containers are knocked or dropped while being moved on or off the racking, or hit by other materials while these are being moved. The risks from the movement of stock should be assessed and appropriate measures implemented to reduce the risk of incident and of harm to individuals in the event of such occurrence. Measures include:

- excluding members of the public from the aisles and area while the containers are being moved – ideally only moving stock when the store is closed;
- appropriate controls to exclude or prevent ignition sources, should spillage of flammable liquid occur. For example, where possible a manually operated pallet truck should be used to move containers, or if a forklift truck has to be used, preference should be given to one that has 'added safety/increased protection' and is equipped with flammable gas detectors to cause it to switch off in the event of flammable liquid spillage.

237 If a designated smoking area for employees, visitors and customers is provided, this should not be sited near the area where the flammable liquid-based products are stored (see Table 1).

238 Staff should be provided with appropriate information and training (see paragraphs 134–138) about the hazards that the flammable liquid-based products pose and how they should be handled and stored correctly. This should include procedures:

- for the regular inspection of the stock, especially that on display, to check for leaking containers etc so that this can be dealt with promptly;

- to ensure that packaging and rubbish is not allowed to accrue where it might pose a fire risk;
- to ensure aisles and fire exits are not restricted, eg by temporary displays or during restocking;
- to ensure the general public are prevented from causing ignition either through ignorance or intent.

239 You should have emergency procedures appropriate to your workplace (see paragraphs 102–120) and ensure your employees are adequately trained in these. These procedures should include cleaning up leaks and spillages, and what to do in case of fire.

Storage in a small retail outlet or shop

240 Where a limited stock of flammable liquid-based products is held on display, provided the capacity of individual containers is typically no more than 10 litres, the following precautions are relevant:

- The stock should be located so as not to restrict the width of gangways or impede any means of escape in the event of incident, and be in a position that can be easily monitored.
- The stock should not be sited above electrical fittings (including lighting) or heating appliances, and should be at least 0.5 m horizontally from and vertically below these unless they are ATEX certified, unless the HAC indicates otherwise (see paragraphs 57–66).
- It is recommended that stock is displayed on lipped shelving or trays so that any leaked liquid can be contained.
- Ensure that staff are aware of the presence of the flammable liquids and have received appropriate information and training (see paragraphs 134–138) as to the precautions necessary to avoid danger and the procedures to be followed to deal with an incident; for example, for cleaning up leaks and spillages, and what to do in case of fire.
- Procedures should be in place to inspect display stock regularly so that any leaking containers etc can be dealt with promptly.

Storage in a small engineering factory or motor vehicle repair shop

241 The flammable liquids should ordinarily be stored in a suitable storage area, building, room or cabinet that is designed to the standards in this book or equivalent. For smaller premises, the use of a suitably designed cabinet (see paragraphs 207–219) should be possible. However, for larger containers, eg metal drums of nominal size 200 litres, this is likely to be inappropriate unless cabinets with enhanced fire performance are used.

242 Where flammable liquids are stored at temperatures at or above their flashpoint, or where such excursion might be anticipated, under DSEAR you must determine the potential extent of the flammable atmosphere that could result from leaks and ensure all potential ignition sources are excluded from such areas (see paragraphs 59–62). This guidance will help you in this exercise. However, it remains for you to determine that the conditions are appropriate for the type and extent of zones detailed to be adopted.

243 On the basis that no more than a few large containers are required to be stored, this can be outdoors subject to the following conditions:

- The storage should be in an enclosed and uncongested location, kept free of combustible materials and away from sources of ignition etc, as detailed in Table 1. Where space is limited, storing the drums against a building wall that is, or can be upgraded to serve as, a fire wall (see paragraphs 161–168) may be possible.
- The drums should stand on level impervious ground away from any drains etc and be provided with appropriate means to contain or limit the spread of spillages. Storing the drums on a pallet may be convenient for easier handling by pallet truck or forklift truck, and also reduces the likelihood of the base of the drum becoming corroded, potentially leading to leaks of flammable liquid.
- Appropriate security should be provided (eg storage in a robust metal lockable cage) and additional protection provided as required to guard against vehicle impact (eg by bollards, or other robust barrier).

244 Alternatively, you may consider using a freight container to provide suitable secure outdoor storage. Where this option is adopted, the freight container will require a number of rudimentary modifications to ensure the safety measures previously discussed for a dedicated storage building are provided (see paragraphs 169–183).

245 If a designated smoking area for employees is provided, this should not be sited near the area where the flammable liquid-based products are stored (see Table 1).

246 Employees should be given appropriate information and training (see paragraphs 134–138) regarding the hazards of the flammable liquids, how they should be handled and stored correctly, and the emergency procedures (see paragraphs 102–120) to be followed in the event of incident.

Storage of higher flashpoint flammable liquids

247 For Category 3 flammable liquids that under normal environmental or workplace operational conditions will always be stored at temperatures below their flashpoint and as a result will not produce a flammable atmosphere, you may not need all the practical measures described in this guidance.

248 While these flammable liquids will not normally produce a flammable atmosphere at the ambient temperatures likely to be encountered during storage, they will readily burn if exposed to fire (and though only pertinent to process activities rather than storage in individual containers, the liquid can be ignited if released as a mist or spray).

249 The following guidance discusses those relaxations appropriate for these higher flashpoint flammable liquids. However, it remains your responsibility by adopting a proportionate approach to the fire and explosion hazards these higher flashpoint flammable liquids pose, to determine through your risk assessment the safety measures that should be implemented (see paragraphs 42–46).

250 Employees should be given appropriate information and training (see paragraphs 134–138) regarding the hazards of the flammable liquids, how they should be handled and stored correctly, and the emergency procedures (see paragraphs 102–120) to be followed in the event of incident.

Storage locations

251 The flammable liquids should be stored in locations where they would not be likely to be rapidly involved in any fire in the vicinity and ideally stored separately from other substances and materials.

252 Where these standards cannot be followed, the higher flashpoint flammable liquids may be held in general storage with other materials, provided these are not incompatible substances (see paragraph 74).

253 In process areas, workrooms, laboratories and similar working areas, higher flashpoint flammable liquids should be stored in a suitably designed cabinet as previously described (see paragraphs 207–220).

254 Where it is necessary to store larger quantities in a workroom, for example in drums, only the minimum quantity consistent with the needs of the operation should be kept there. They should be stored at least 3 m and preferably 5 m from process activities. It is particularly important to keep sources of heat away from the area in which the drums are stored.

Design of stores

255 Provision of a means of containing spillages and/or limiting the extent they can spread is recommended. Additionally there may be separate requirement for this to prevent harm to the environment (see paragraph 14).

256 For storage rooms or buildings used to store only higher flashpoint flammable liquids, a lower standard of ventilation is sufficient. This may, for example, be provided by a limited number of air bricks in one or more of the external walls. Explosion relief is not considered necessary.

257 Although fire-resistance performance standards for the store are not mandatory, they may be appropriate to reduce the risk of a fire spreading.

Operations

258 Dispensing, mixing and similar operations should normally be done away from the storage area.

259 However, where the hazards associated with moving the containers appear to outweigh the fire hazard, such operations can be carried out in the storage area, providing that precautions are taken against spillage and adequate ventilation is provided.

Retail premises

260 Full containers may be kept on display if the number is kept to a reasonable level. They should be stacked in a safe manner, away from heating appliances, any large sources of ignition and readily combustible materials (such as paper and cardboard); and in a manner which does not restrict the means of escape in case of fire for staff or customers.

261 Paint tinting systems may be used in the sales area providing it is kept clean and well ventilated. The tinting equipment itself is normally non-combustible.

262 If the liquid is not heated above its flashpoint or released from the container in the form of a mist or spray, then it will not generate a hazardous area. Therefore HAC (see paragraphs 59–62) and the use of ATEX-certified plant and equipment is not required.

263 Special precautions are not required for vehicles, but normal traffic management and control procedures should be implemented to prevent customers' vehicles causing damage to the containers where they are stored.

Appendix 1 Physical barriers of fire-resisting construction

See the following sections from *Dangerous Substances and Explosive Atmospheres. Dangerous Substances and Explosive Atmospheres Regulations 2002. Approved Code of Practice and guidance L138* (Second edition, 2013) for information on design and performance requirements of physical barriers of fire-resisting construction:

- paragraphs 266–279;
- Appendix 3 Fire resistance;
- Appendix 5 Fire reaction.

Appendix 2 Mechanical exhaust ventilation (MEV)

- 1 The following requirements apply where mechanical exhaust ventilation (MEV) systems are to be installed in rooms or buildings used for storing flammable liquids in containers where natural ventilation cannot be provided.
- 2 Where MEV is provided it needs to operate continuously. Failure or critical diminution of the exhaust air flow should be detected by an airflow monitoring device installed in the ductwork (such as a flow switch or differential pressure switch) and linked to an alarm.
- 3 The exhausted air should discharge to a safe place in the open air. Where ductwork is required to achieve this, it should be fire-resisting (see Appendix 1) and arranged so that vapours cannot condense and collect at low points within it. In most cases it will be adequate if the MEV exhausts:
 - at least 3 m above ground level;
 - at least 3 m from building openings, boundaries, sources of ignition; and
 - away from building eaves and other obstructions.
- 4 Requirements for positioning exhausts from ventilation systems may be found in Process Guidance Notes issued by Defra.²¹
- 5 MEV should be included in the hazardous area classification assessment for the premises (see L138, regulation 7 and Schedules 2–4). It is normally appropriate to consider the internal volumes of the MEV system, including ductwork, to be zone 2.
- 6 Where the MEV is provided by a fan assembly in an external wall leading directly to outside, it should be ATEX-certified for use in the zone determined. This includes the fan impellers, casing and couplings. A relevant design standard for fans on MEV systems in relation to hazardous explosive atmospheres is BS EN 14986.²²
- 7 Where the MEV incorporates ductwork, the fan electric motor should not be installed within the ductwork. Instead, a centrifugal or bifurcated fan should be used. As the fan impeller necessarily has to be in the path of the flammable liquid vapours being extracted, it does present a potential ignition source from static discharge, frictional sparking or rubbing. To prevent this, the fan impeller, its casing and couplings should be ATEX-certified as suitable for use in the zone determined for the ductwork.
- 8 Further guidance on MEV is given in L138 and in the following HSE guidance:
 - *Clearing the air. A simple guide to buying and using local exhaust ventilation (LEV)* INDG408;²³
 - *Time to clear the air! A workers' pocket guide to local exhaust ventilation (LEV)* INDG409;²⁴
 - *Controlling airborne contaminants at work: A guide to local exhaust ventilation (LEV)* HSG258;²⁵
 - local exhaust ventilation (LEV) workplace dust and fume extraction HSE webpages at www.hse.gov.uk/lev.

Appendix 3 Other relevant health and safety legislation

Management of Health and Safety at Work Regulations 1999 (the Management Regulations)

- 1 The Management Regulations require employers and the self-employed to assess the general risks to health and safety arising from their work activity and identify the preventive and protective measures that need to be taken to control the identified risks.
- 2 The more specific provisions of DSEAR (see paragraph 17) will only apply where dangerous substances are present or used. For example, an assessment of the risks from dangerous substances and arrangements for emergencies carried out under DSEAR will not need to be repeated under the Management Regulations, and may be incorporated into the more general 'management' assessment as a subset.
- 3 There are legal requirements, in other regulations, to consult employees. It can be helpful to involve employees or their representatives when carrying out risk assessments.

Control of Substances Hazardous to Health Regulations 2002 (COSHH)

- 4 Flammable liquids are dangerous (to safety) in terms of DSEAR, but they are also likely to present a health risk for which COSHH will apply. The supplier's SDS should provide information on this, where the employer will have duties to control the health and safety risks under both COSHH and DSEAR. By considering the requirements together, development and implementation of a single set of safety measures to satisfy the requirements of both sets of regulations should be possible.

CLP and CHIP

- 5 From 1 June 2015, chemical suppliers must comply only with the CLP Regulation.
- 6 European Regulation (EC) No 1272/2008 on Classification, Labelling and Packaging of Substances and Mixtures (known as the CLP Regulation or CLP) has repealed both the Dangerous Substances Directive (67/548/EEC) and the Dangerous Preparations Directive (99/45/EC) and became the primary legislation in this area.
- 7 The CLP Regulation adopts across the European Union the United Nations' Globally Harmonised System on chemical classification and labelling (GHS). The CLP Regulation is directly acting on all European Union member states. This means that, unlike with directives, no national transposition is necessary and the need for the Chemicals (Hazard Information and Packaging for Supply) Regulations 2009 (CHIP Regulations) falls away. However, regulation 12 of CHIP requires that the person who is responsible for first supplying a dangerous preparation has to keep a record of the information for at least three years after it is last supplied; this provision of CHIP will remain until June 2018, after which CHIP is fully revoked.

8 Preparations classified, labelled and packaged in accordance with CHIP and placed on the market before 1 June 2015, do not need to be relabelled and repackaged in accordance with the CLP Regulation until 1 June 2017. Product hazard labels must only show the details of one regime – ‘mixed’ labels are not permitted.

Provision and Use of Work Equipment Regulations 1998 (PUWER)

9 These Regulations ensure that safe work equipment is provided, maintained in good working order and is safely used. Regulation 12 of PUWER is particularly relevant to equipment associated with flammable liquids, as it requires employers to ensure that people using work equipment are not exposed to hazards arising from:

- equipment catching fire or overheating;
- the unintended or premature discharge of any liquid or vapour;
- the unintended or premature explosion of the work equipment or any substance used or stored in it.

Equipment and Protective Systems Intended for Use in Potentially Explosive Atmospheres Regulations 1996 (EPS)

10 EPS applies to the supply of both electrical and mechanical equipment and protective systems intended for use in potentially explosive atmospheres. New equipment etc supplied for use in places where an explosive atmosphere may occur must meet the requirements of EPS whatever its source.

Planning (Hazardous Substance) Regulations 1992

11 Sites, manufacturing or processing flammable liquids may be required to apply for permission under the Planning (Hazardous Substance) Regulations 1992 in England and Wales or the Town and Country Planning (Hazardous Substances) (Scotland) Regulations 1993. Application is usually to the local planning authority with HSE being a statutory consultee in the application process.

Dangerous Substances (Notification and Marking of Sites) Regulations 1990 (NAMOS)

12 NAMOS aims to ensure that firefighters arriving at an incident are warned of the presence of dangerous substances. Advice on NAMOS is available in *Notification and marking of sites* HSR29.²⁶

Control of Major Accident Hazards Regulations 1999 (COMAH)

13 COMAH aims to prevent and mitigate the effects of those major accidents involving dangerous substances which can cause serious damage/harm to people and/or the environment. The COMAH Regulations treat risks to the environment as seriously as those to people. For further guidance on COMAH see the HSE website www.hse.gov.uk/comah/guidance.htm.

Consulting employees and safety representatives

14 Employers must consult safety representatives appointed by recognised trades unions under the Safety Representatives and Safety Committees Regulations 1977. Employees who are not covered by such representatives must be consulted either directly or indirectly, through elected representatives of employee safety under the Health and Safety (Consultation with Employees) Regulations 1996.

15 Proper consultation with those who know precisely how the work is done, including short cuts, is crucial and helps to build a culture of awareness of health and safety. It can benefit the business by making it more efficient and reducing losses and damage.

Electricity at Work Regulations 1989

16 These Regulations impose health and safety duties for the safe use of electricity at work. They require electrical installations and equipment to be properly constructed, maintained and fit for the purpose and environment in which they are to be used. In particular, they require electrical equipment which is exposed (or reasonably expected to be exposed) to a flammable or explosive substances, including flammable vapours or gases, to be constructed or protected so as to prevent danger. Advice is available in *The Electricity at Work Regulations 1989. Guidance on Regulations* HSR25.²⁷

Carriage of Dangerous Goods and Use of Transportable Pressure Equipment Regulations 2009 (CDG)

17 Carrying goods by road or rail involves the risk of traffic accidents. If the goods are dangerous, there is also the risk of incidents, such as spillage, leading to hazards such as fire, explosion, chemical burn or environmental damage. The CDG Regulations implement ADR with a number of exceptions which can be found in the *Carriage of dangerous goods: Approved derogations and transitional provisions* document at <https://www.gov.uk/government/publications/the-carriage-of-dangerous-goods-approved-derogations-and-transitional-provisions>.

Health and Safety (Safety Signs and Signals) Regulations 1996

18 These Regulations implement a European Council Directive on minimum requirements for provision of workplace safety signs. The Directive standardises use throughout EU member states to ensure particular signs provide the same message wherever witnessed.

Health and Safety Enforcing Authority Regulations 1998

19 These Regulations allocate to local authorities the responsibility for enforcing the HSW Act and its relevant statutory provisions, subject to specific exceptions, in all premises where the main activity is listed in Schedule 1 to the Regulations.

Food and Environment Protection Act 1985 (FEPA)

20 All pesticides are subject to FEPA, this guidance covers safety aspects of the flammability hazards of those pesticides which are also flammable liquids.

21 Further guidance on the safe storage of pesticides may be found in *Guidance on storing pesticides for farmers and other professional users* AIS16.²⁸

Petroleum (Consolidation) Regulations 2014

22 These regulations apply to workplaces that store petrol and dispense it through manual or electrical pumping from a storage tank directly into the tank of a vehicle with an internal combustion engine. These Regulations also apply to storage of petrol at non-workplace premises, eg private homes, clubs, associations etc.

References

- 1 *The safe use and handling of flammable liquids* HSG140 (Second edition) HSE Books 2014 ISBN 978 0 7176 6609 6 www.hse.gov.uk/pubns/books/hsg140.htm
- 2 *The storage of flammable liquids in tanks* HSG176 (Second edition) HSE Books 2014 ISBN 978 0 7176 6607 2 www.hse.gov.uk/pubns/books/hsg176.htm
- 3 *Dangerous substances and explosive atmospheres. Dangerous Substances and Explosive Atmospheres Regulations 2002. Approved Code of Practice and guidance* L138 (Second edition) HSE Books 2013 ISBN 978 0 7176 6616 4 www.hse.gov.uk/pubns/books/l138.htm
- 4 *Guidance for the storage of liquids in intermediate bulk containers* Chemical Business Association and Solvents Industry Association www.chemical.org.uk/regulatoryissues/healthandsafety/jointcbasiastorageguidance.aspx
- 5 BS EN 60079-10-1:2009 *Explosive atmospheres. Classification of areas. Explosive gas atmospheres* British Standards Institution
- 6 *Model Code of Safe Practice Part 15: Area Classification Code for Installations Handling Flammable Fluids* (Third edition) Energy Institute 2005 www.energypublishing.org
- 7 *Chemical warehousing: The storage of packaged dangerous substances* HSG71 (Fourth edition) HSE Books 2009 ISBN 978 0 7176 6237 1 www.hse.gov.uk/pubns/books/hsg71.htm
- 8 *Managing contractors: A guide for employers* HSG159 (Second edition) HSE Books 2011 ISBN 978 0 7176 6436 8 www.hse.gov.uk/pubns/books/hsg159.htm
- 9 *Guidance on permit-to-work systems: A guide for the petroleum, chemical and allied industries* HSG250 HSE Books 2005 ISBN 978 0 7176 2943 5 www.hse.gov.uk/pubns/books/hsg250.htm
- 10 *Emergency planning for major accidents: Control of Major Accident Hazards Regulations 1999* HSG191 HSE Books 1999 ISBN 978 0 7176 1695 4 www.hse.gov.uk/pubns/books/hsg191.htm
- 11 *The control of fire-water run-off from CIMAH sites to prevent environmental damage* Environmental Hygiene Guidance Note EH70 HSE Books 1995 www.hse.gov.uk/pubns/books/eh70.htm
- 12 *Containment systems for the prevention of pollution: Secondary, tertiary and other measures for industrial and commercial premises* C736 CIRIA www.ciria.org
- 13 *Fire safety in construction: Guidance for clients, designers and those managing and carrying out construction work involving significant fire risks* HSG168 (Second edition) HSE Books 2010 ISBN 978 0 7176 6345 3 www.hse.gov.uk/pubns/books/hsg168.htm
- 14 BS 9999:2008 *Code of practice for fire safety in the design, management and use of buildings* British Standards Institution

- 15 BS EN 3-7:2004+A1:2007 *Portable fire extinguishers. Characteristics, performance requirements and test methods* British Standards Institution
- 16 *Safety signs and signals. The Health and Safety (Safety Signs and Signals) Regulations 1996. Guidance on Regulations L64* (Third edition) HSE Books 2015 ISBN 978 0 7176 6598 3 www.hse.gov.uk/pubns/books/l64.htm
- 17 BS EN ISO 7010:2012 *Graphical symbols. Safety colours and safety signs. Registered safety signs*. British Standards Institute
- 18 BS 5925:1991 *Code of practice for ventilation principles and designing for natural ventilation* British Standards Institution
- 19 BS EN 14470-1:2004 *Fire safety storage cabinets. Safety storage cabinets for flammable liquids* British Standards Institution
- 20 NFPA 30 *Flammable and combustible liquids code*
www.nfpa.org/catalog/product.asp?pid=NFPA30ARCHIV&cookie%5Ftest=1
- 21 Environmental Protection Act 1990. Part 1 Integrated pollution control and air pollution control by local authorities. Defra Solvent sector Process Guidance Notes and Petroleum and Powder Coatings Sector Process Guidance Notes
www.defra.gov.uk/industrial-emissions/las-regulations/guidance/
- 22 BS EN 14986:2007 *Design of fans working in potentially explosive atmospheres* British Standards Institution
- 23 *Clearing the air: A simple guide to buying and using local exhaust ventilation (LEV)* Leaflet INDG408 HSE Books 2008 www.hse.gov.uk/pubns/indg408.htm
- 24 *Time to clear the air! A workers' pocket guide to local exhaust ventilation (LEV)* INDG409 HSE Books 2008 www.hse.gov.uk/pubns/indg409.htm
- 25 *Controlling airborne contaminants at work: A guide to local exhaust ventilation (LEV)* HSG258 (Second edition) HSE Books 2011 ISBN 978 0 7176 6415 3 www.hse.gov.uk/pubns/books/hsg258.htm
- 26 *Notification and marking of sites. The Dangerous Substances (Notification and Marking of Sites) Regulations 1990. Guidance on Regulations* HSR29 HSE Books 1990 ISBN 978 0 1188 5435 1 www.hse.gov.uk/pubns/hsr29.htm
- 27 *The Electricity at Work Regulations 1989. Guidance on Regulations* HSR25 (Third edition) HSE Books 2015 ISBN 978 0 7176 6636 2 www.hse.gov.uk/pubns/hsr25.htm
- 28 *Guidance on storing pesticides for farmers and other professional users* AIS16(rev1) HSE 2012 www.hse.gov.uk/pubns/ais16.htm

Glossary

ADR European Agreement concerning the International Carriage of Dangerous Goods by Road.

ALARP as low as reasonably practicable.

ambient the temperature of an immediate locality.

ATEX the collective name for the Explosive Atmospheres Directives 99/92/EC and 94/9/EC of the European Parliament. Both deal with precautions for explosive atmospheres. The first (also known as ATEX 137) focuses on worker safety and the second ('ATEX 95' or 'the ATEX Equipment Directive') focuses on the correct standard of equipment to avoid ignition. Also see EPS.

auto-ignition temperature (AIT) the minimum temperature at which a material will ignite spontaneously under specified test conditions. Also referred to as the minimum ignition temperature.

bund an area surrounded by a bund wall or sill, in which liquid spillage is contained. Also the raised perimeter of an area used to contain and prevent the spreading of liquids.

CDG Carriage of Dangerous Goods and Use of Transportable Pressure Equipment Regulations 2009.

CHIP Chemicals (Hazard Information and Packaging for Supply) Regulations 2009.

CLP European Classification, Labelling and Packaging of Substances and Mixtures Regulation 2008.

COMAH Control of Major Accident Hazards Regulations 1999.

combustible capable of burning in air when ignited.

DSEAR the Dangerous Substances and Explosive Atmospheres Regulations 2002.

element of construction any wall, floor, ceiling, roof, door or window (including the frame) etc which forms part of a building, room or other enclosure.

enforcing authority the authority with responsibility for enforcing the HSW Act and other relevant statutory provisions.

EPS Equipment and Protective Systems for use in Potentially Explosive Atmospheres Regulations 1996 implementing Directive 94/9/EC of the European Parliament.

explosive atmosphere an ignitable mixture of flammable vapour with the air, which has the potential to catch fire or explode if ignited.

fire-resisting construction a physical barrier, such as a wall, ceiling or partition that a particular period of fire resistance. See Appendix 2.

fire resistance the measure of the ability of a physical barrier to withstand the effects of fire to prevent one or more of the following: the passage of flame and hot

gases; the transfer of excessive heat; and maintain the load-bearing capacity of the physical barrier. See Appendix 2.

fire wall an imperforate wall, screen or partition capable of affording at least 30 minutes fire resistance. See Appendix 2.

flammable capable of burning with a flame.

flammable liquid for the purpose of this book, flammable liquid means a liquid with a flashpoint of 60 °C or below and stored at a near atmospheric pressure.

flashpoint the minimum temperature at which a liquid, under specific test conditions, gives off sufficient flammable vapour to ignite momentarily on the application of an ignition source.

hazard something that could cause harm to people.

hazardous area an area where flammable or explosive gas, or vapour–air mixtures (often referred to as explosive gas–air mixtures) are, or may be expected to be, present in quantities which require special precautions to be taken against the risk of ignition. See Appendix 1.

higher flashpoint flammable liquid flammable liquids with a flashpoint up to 60 °C that under normal environmental or workplace operational conditions will always be stored at temperatures below their flashpoint.

hot work this includes welding or the use of any equipment likely to cause flame, sparks or heat.

incendive having sufficient energy to ignite a flammable mixture.

interceptor (also known as ‘separator’) a device installed in a surface water drainage system to separate out any immiscible solvents and thus prevent them from reaching public drains, sewers or watercourses.

lower explosion limit (LEL) the minimum concentration of vapour in air below which propagation of a flame will not occur in the presence of an ignition source. Also referred to as the lower flammable limit or lower explosive limit.

lower flashpoint flammable liquid those flammable liquids categorised as extremely and highly flammable liquids under CLP or CHIP, and other flammable (and combustible) liquids that may be stored at temperatures above their flashpoint.

non-combustible material a material that fulfils the criteria for non-combustibility given in BS 476 Part 4, Part 11 or equivalent European Harmonised Standard. See Appendix 1.

permit-to-work (PTW) a document issued by an authorised person to permit work to be carried out safely in a defined area under specified conditions.

reasonably practicable this means balancing the level of risk against the measures needed to control the real risk in terms of money, time or trouble. However, you do not need to take action if it would be grossly disproportionate to the level of risk.

risk the chance – however large or small – that a hazard could cause harm.

sill the raised perimeter of an area used to contain and prevent the spreading of liquids.

ullage space the free space between the fluid level and the top of its container, to allow for expansion.

upper explosion limit (UEL) the maximum concentration of vapour in air above which the propagation of a flame through the mixture will not occur. Also referred to as the upper flammable limit or the upper explosive limit.

vapour the gaseous phase released by evaporation from a material that is a liquid at normal temperatures and pressure.

viscosity the degree to which a fluid tends to resist relative motion within itself. Examples of viscous fluids are treacle and heavy fuel oils.

vulnerable population persons who may require additional help in moving to a place of safety in the event of an incident; for example those in schools, hospitals, old people's homes and other residential accommodation.

zone the classified part of a hazardous area, representing the probability of a flammable vapour (or gas) and air mixture being present. These are defined in Schedule 2 to regulation 7(1) of DSEAR.³

Further information

For information about health and safety, or to report inconsistencies or inaccuracies in this guidance, visit www.hse.gov.uk/. You can view HSE guidance online and order priced publications from the website. HSE priced publications are also available from bookshops.

British Standards can be obtained in PDF or hard copy formats from BSI: <http://shop.bsigroup.com> or by contacting BSI Customer Services for hard copies only Tel: 0845 086 9001 email: cservices@bsigroup.com.

The Stationery Office publications are available from The Stationery Office, PO Box 29, Norwich NR3 1GN Tel: 0870 600 5522 Fax: 0870 600 5533 email: customer.services@tso.co.uk Website: www.tsoshop.co.uk. (They are also available from bookshops.) Statutory Instruments can be viewed free of charge at www.legislation.gov.uk where you can also search for changes to legislation.

This guidance is issued by the Health and Safety Executive. Following the guidance is not compulsory, unless specifically stated, and you are free to take other action. But if you do follow the guidance you will normally be doing enough to comply with the law. Health and safety inspectors seek to secure compliance with the law and may refer to this guidance.

This guidance is available online at: www.hse.gov.uk/pubns/books/hsg51.htm

© *Crown copyright* If you wish to reuse this information visit www.hse.gov.uk/copyright for details. First published 09/15