



THORNE &
DERRICK
INTERNATIONAL

Thorne & Derrick
+44 (0) 191 490 1547
www.heatingandprocess.com



AYLESBURY

K VALVE

INSTALLATION GUIDE

FOR VALVE SIZES (DN):

2'' (50) HF

2½'' (65) SF

3'' (80) RB

IMPORTANT

PLEASE KEEP FOR FUTURE REFERENCE.

PLEASE READ THESE INSTRUCTIONS
CAREFULLY AND REFER TO ANY DIAGRAMS
BEFORE INSTALLATION.

These instructions contain important information which will help you install your **KERAFLO** delayed action float valve correctly and ensure safe use and maintenance.

For further assistance please ring our
Customer Helpline: **0118 921 9920**

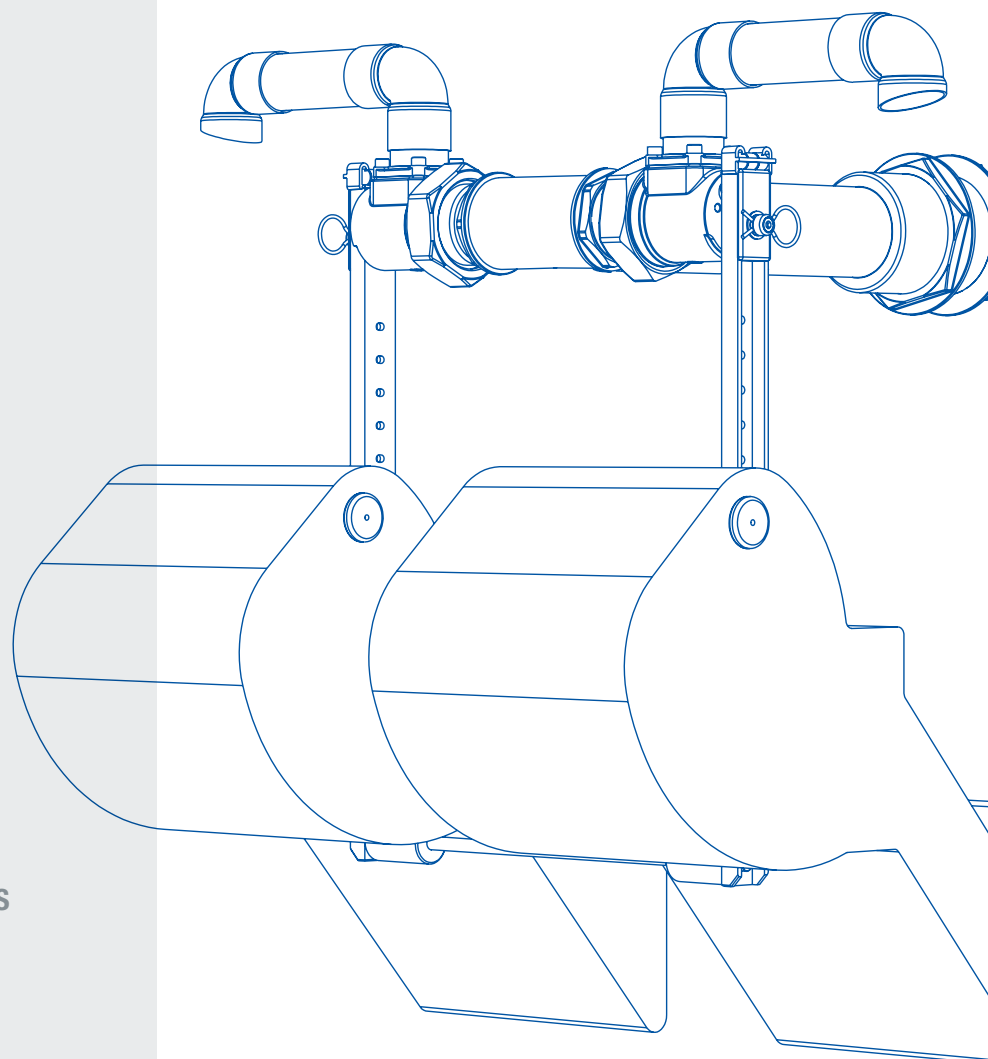

THORNE &
DERRICK
INTERNATIONAL

Thorne & Derrick
+44 (0) 191 490 1547
www.heatingandprocess.com

KERAFLO AYLESBURY VALVES ARE UNLIKE ANY OTHER FLOAT OPERATED VALVE, BALLCOCK OR FLOAT VALVE.

KERAFLO Aylesbury delayed action float valves contain a pair of maintenance free ceramic discs.

There are rare occasions when it may be necessary to partially disassemble the valve, for example, to clear a blockage or to replace some parts.

If the problem you are experiencing cannot be solved by using a spares kit, you may need to replace the entire valve. Contact **KERAFLO** or your supplier for details.

IMPORTANT

PLEASE READ THESE INSTRUCTIONS CAREFULLY AND REFER TO ANY DIAGRAMS BEFORE INSTALLATION.

INSTALLATION OF VALVES SHOULD BE IN ACCORDANCE WITH THE WATER SUPPLY (WATER FITTINGS) REGULATIONS 2010 AND BS 8558:2011.

TANKS AND PIPES SHOULD BE DISINFECTED USING THE PROCEDURES IN BS EN 806-4:2010 SECTION 6: COMMISSIONING.

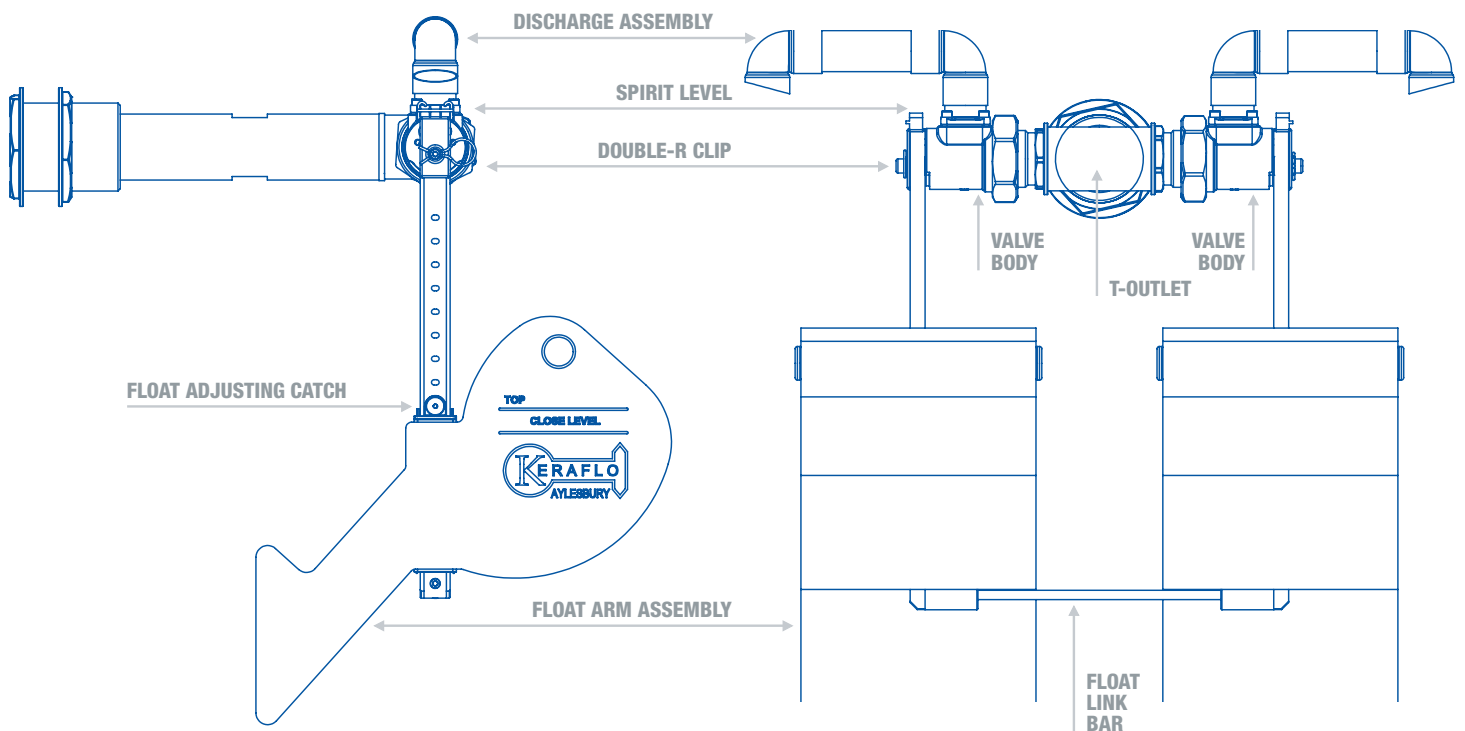

5 YEAR
EXTENDED

Once the valve has been installed and tested, complete and apply the tank label to the tank and send a photograph of the label in place to warranties@keraflo.co.uk in order to receive a full five years' extended warranty for the valve. See warranty



**THORNE &
DERRICK
INTERNATIONAL**

Thorne & Derrick
+44 (0) 191 490 1547
www.heatingandprocess.com

PRE-INSTALLATION CHECKS

RAISED VALVE CHAMBERS:

Do not use a K Type valve with a raised valve chamber.
Use a KAX or KB Type valve for these tanks.

OPERATING SPACE:

Check for sufficient clearance. The working dimensions are shown on the attached drawings on page 7 & 8.

OVERFLOW/WARNING PIPES:

Check the position of the overflow and warning pipe, where fitted (see drawing on page 7).

TURBULENT WATER:

Exceptionally turbulent waters, such as in cooling towers, should be avoided directly beneath the float. Calming measures such as baffle plates, still ponds etc. should be used in these installations.

FLANGED TANKS:

The design of the valves, allows sufficient clearance between the float and most internal tank flanges and ribs (see drawings on pages 7 & 8). The valve backnuts may be adjusted to enable fitting to tanks with large flanges; provided a minimum of 20mm exists between the float and tank wall throughout the arc of the float.

ROUND TANKS:

Minimum tank diameters required.

VALVE	2"HF	2½"SF	3"RB
MIN TANK DIAMETER (M)	0.6M	0.6M	0.6M

NOTE: TO ENSURE SUFFICIENT OPERATING CLEARANCE IT MAY BE NECESSARY TO EXTEND THE PIPEWORK TO POSITION THE VALVE ASSEMBLY IN THE CENTRE OF THE TANK CHAMBER.

SLOPING TANK WALL:

The wall to which the Aylesbury K Valve is to be attached must be vertical. If the wall around the fixing hole is sloped, tapered washers must be used. These should be available from the tank supplier.

PIPEWORK SUPPORT:

KERAFLO Aylesbury valves create virtually no tank wall stress. It is therefore not necessary to provide additional support to the pipework as long as the Code of Practice for the Support of Pipework in general is met.

ISOLATING VALVE:

An isolating valve must be fitted as near as is reasonably practicable to the **KERAFLO** valve.



**THORNE &
DERRICK
INTERNATIONAL**

Thorne & Derrick
+44 (0) 191 490 1547
www.heatingandprocess.com

INSTALLATION INSTRUCTIONS

The valve is supplied with the float arm and discharge assemblies detached. To avoid damage it is recommended, where possible, to fit both of these assemblies **AFTER** installing the valve in the tank.

- 1 Before fitting the valve, flush the supply pipes to clear all debris.
- 2 Remove and retain the double-R clips from both valve bodies.
- 3 Remove and discard the red protective cap from the tail.
- 4 Remove and retain one inlet backnut from the T-outlet.
- 5 Insert the valve tail through the hole in the tank wall observing the side of the T-outlet marked "TOP".
- 6 Replace the backnut with the flanged side against the tank wall.
- 7 Level the two valves on the T-outlet by placing a spirit level across the T-outlet, parallel to the tank wall on which it is mounted and twisting the whole assembly to bring the assembly level.
- 8 Tighten the backnut sufficiently to hold the assembly in position but note that it may be necessary to move the assembly later after the float clearances have been measured.
- 9 Fit the float arm assemblies, fixing them in place with the parts retained at step 2

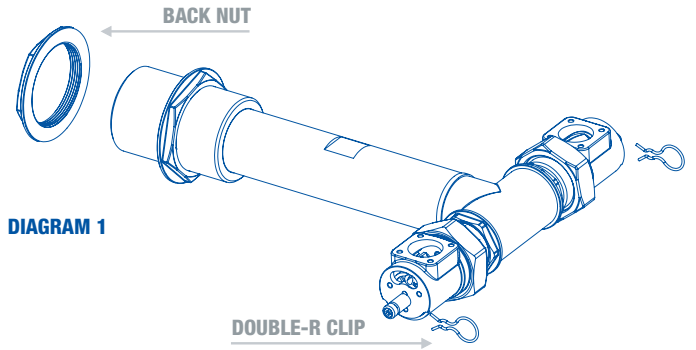

DIAGRAM 1

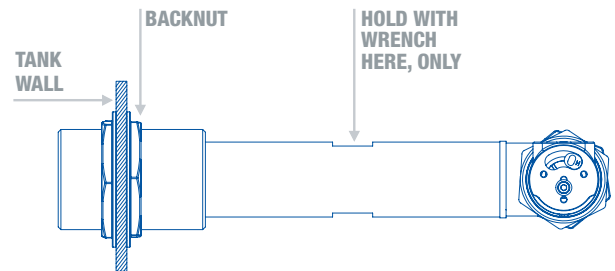

DIAGRAM 2

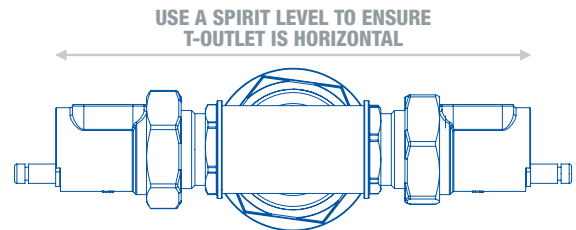
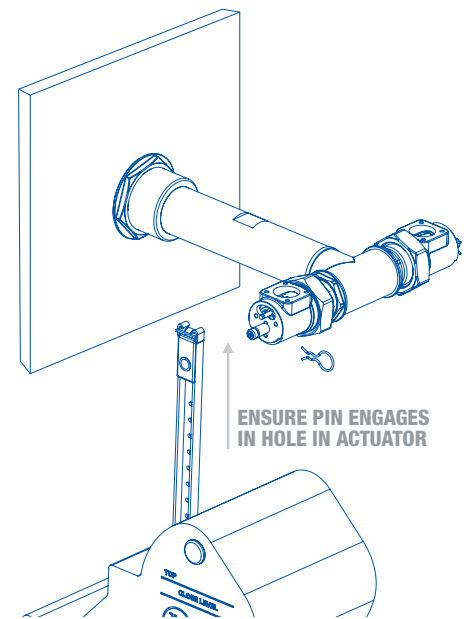

DIAGRAM 3



THORNE & DERRICK INTERNATIONAL

Thorne & Derrick
 +44 (0) 191 490 1547
 www.heatingandprocess.com

- 10 The float arms should hang vertically with the built-in spirit level bubbles exactly between the black lines as shown in diagram 4.
- ENSURE THAT THE FLOAT ARM OPERATING PINS ENGAGE IN THE HOLES IN THE ACTUATOR WHEELS AND THAT THE FLOAT MARKED WITH A RED DOT IS FITTED TO THE VALVE WHICH IS ALSO MARKED WITH A RED DOT.**
- 11 If the valves are not level, each individual valve can be rotated at its screwed connection into the T-outlet. This joint is sealed by an “o”-ring so can be moved without fear of a leak.
- 12 Loosen the locknuts on the valve body and rotate each valve individually as necessary so that the float arms are **ABSOLUTELY VERTICAL**.
- 13 Align each valve, tighten the locknut and re-check the alignment. **EACH BUBBLE MUST BE PRECISELY BETWEEN THE BLACK LINES.**
- 14 Check that the clearance between the tank wall and the floats is at least 25mm, when the float arms are vertical. If it is less than this move the assembly further into the tank by adjusting the valve backnuts and repeating steps 6 to 8.
- 15 When the clearance and the levels are correctly set, fully tighten the backnuts holding the assembly to the tank wall.
- 16 Using the 4mm Allen key supplied, remove the two M5x12 screws from the ends of the float link bar.
- 17 Place the bar between the lowest holes of

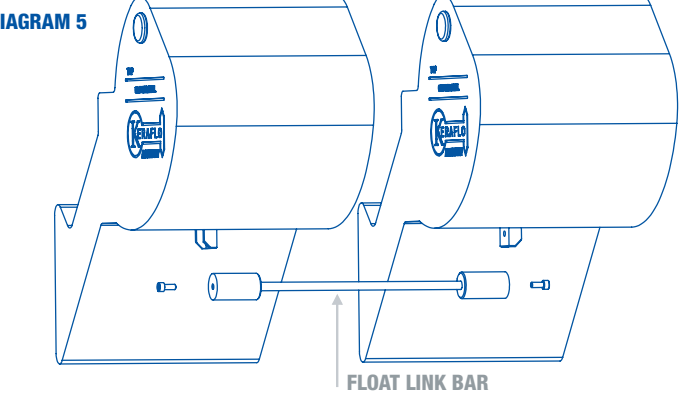
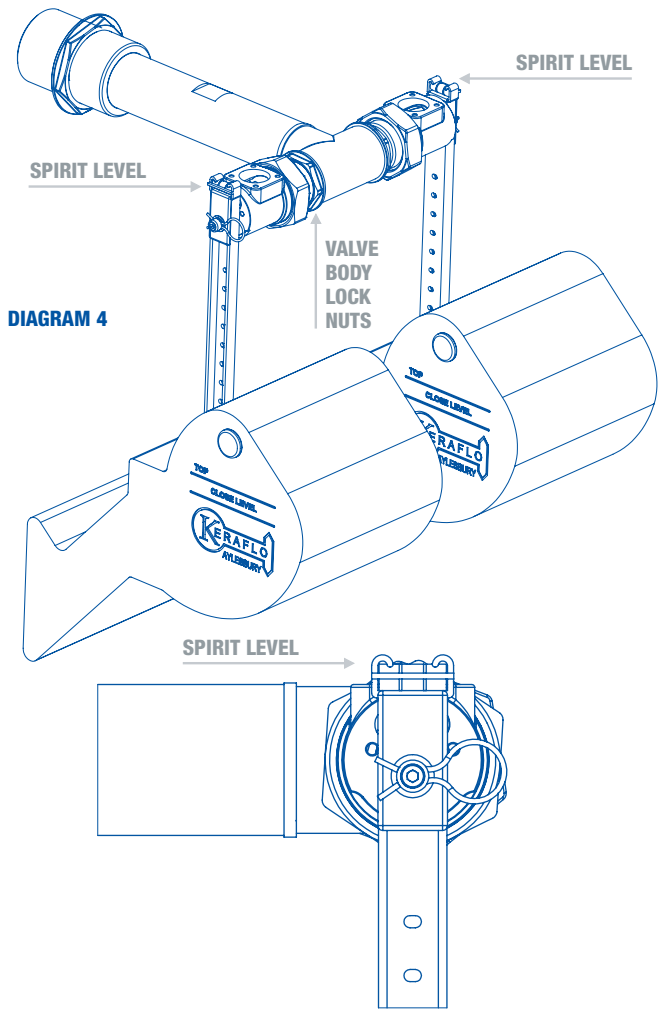

WARNING!
THE BUILT-IN SPIRIT LEVEL MUST BE USED TO ALIGN THIS VALVE. FAILURE TO FOLLOW THE PROCEDURE LISTED BELOW WILL PREVENT THE VALVE OPERATING CORRECTLY.
INSTALLATION OF VALVES SHOULD BE IN ACCORDANCE WITH THE WATER SUPPLY (WATER FITTINGS) REGULATIONS 2010 AND BS 8558:2011.



Thorne & Derrick
 +44 (0) 191 490 1547
 www.heatingandprocess.com

- 18 Tighten using the Allen key, ensuring that the Float Arms remain parallel.
- 19 Connect the supply pipe after an isolating valve and hand tighten the connection backnut. To prevent the valve turning when tightening the pipe fitting, use either a wrench or a spanner on the valve tail where indicated in Diagram 2. **DO NOT USE A WRENCH ON ANY OTHER PART OF THE VALVE.**
- 20 Remove and discard the protective caps from the discharge assemblies before adjusting the closing level and commissioning the valve.
- 21 Using the 4mm Allen key supplied, fit the discharge assemblies referring to Diagram 6 for the direction.

ADJUSTING CLOSING WATER LEVEL (TWL)

- 1 Pull out the float adjusting catches.
- 2 Move the floats to the desired position.
- 3 Release catches and ensure the pins locate in desired hole.
- 4 **ENSURE THAT BOTH FLOATS ARE SET TO THE SAME LEVEL.**
- 5 The delayed action (level differential) is the difference between the Opening and the Closing Levels. This will be between 50 and 100mm depending on the float position and is not adjustable.

DIAGRAM 6

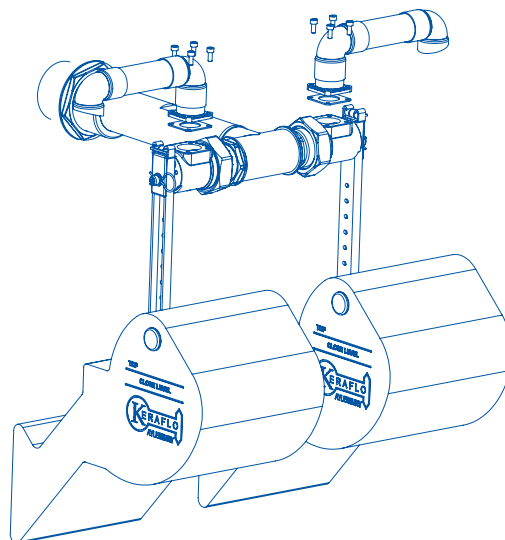

ALIGNMENT WARNING!

THE FLOAT ARMS MUST BE FITTED IN THE VERTICAL POSITION WHEN THE VALVES ARE FULLY OPEN. THIS IS CRITICAL TO THE OPERATION OF THE VALVES.

DIAGRAM 7

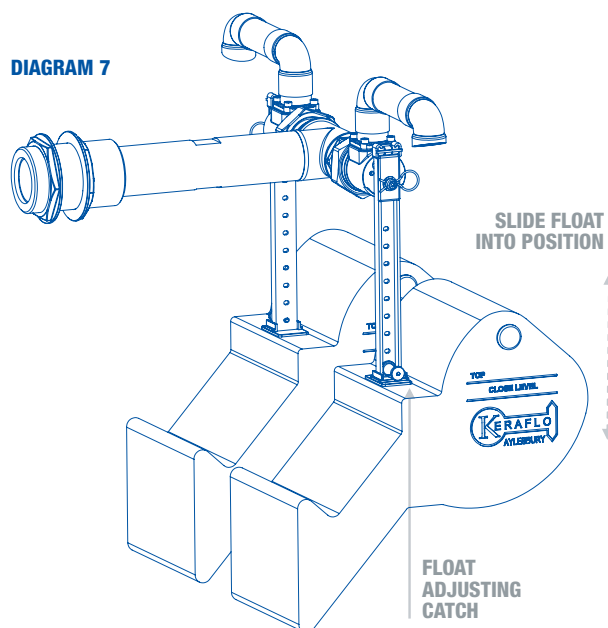

TESTING

Before leaving the installation, manually move the valves to test their operation a number of times, ensuring that they move freely from the open to the closed position and from the closed to the open position.

Where a valve has not been in operation for

Thorne & Derrick
+44 (0) 191 490 1547
www.heatingandprocess.com



SIZES (DN):

2”(50)HF

2½”(65)SF

3”(80)RB

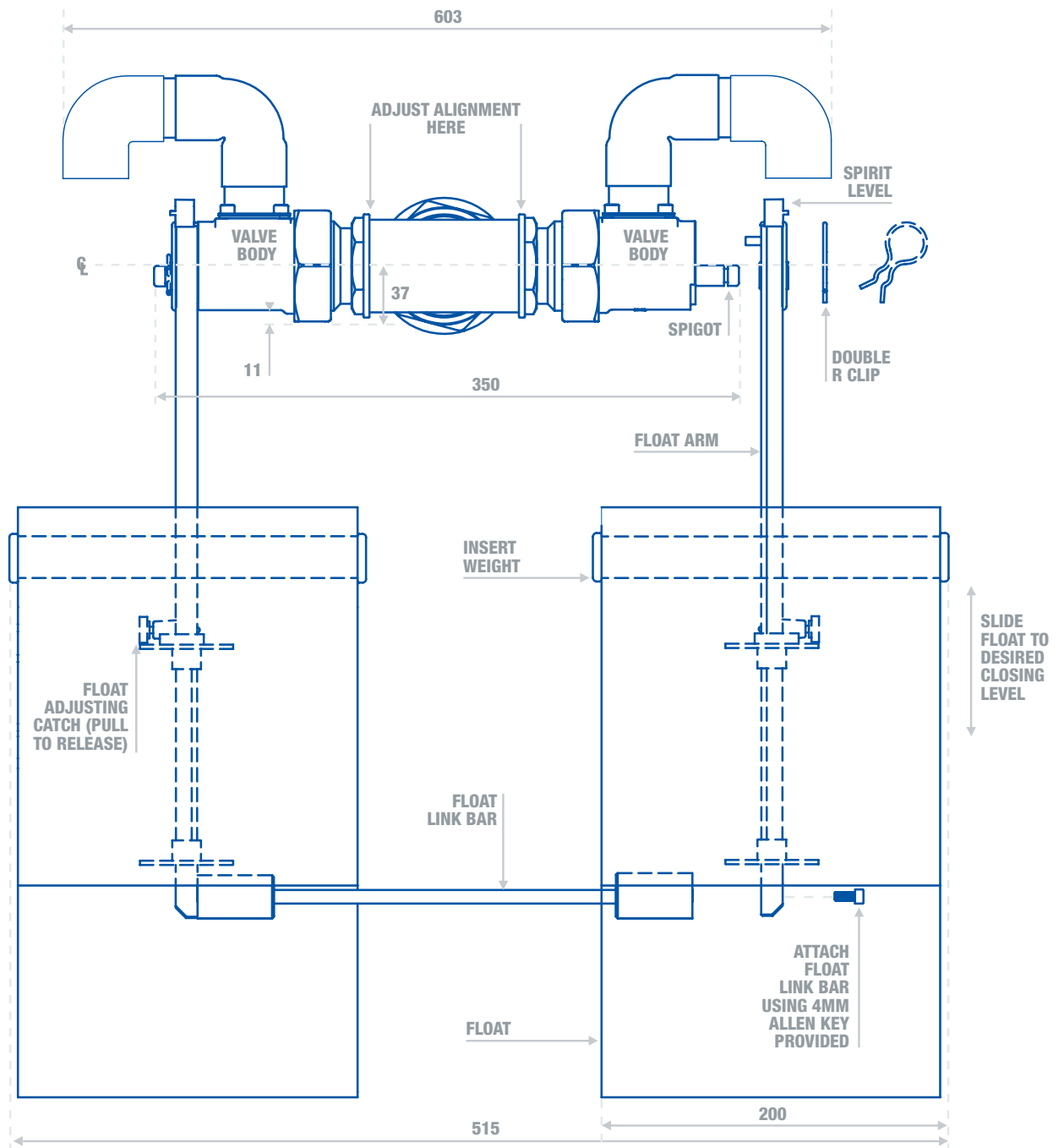

BASIC SPECIFICATION:

Maximum static pressure: 10bar

Maximum flow rate: 3m/s nominal pipe velocity (Flow Rate and Pipe Velocity chart is available at www.keraflo.co.uk)

Temperature range: 1° – 60°C

Level differential: 50 - 100mm non-adjustable delayed action

S





SIZES (DN):

2”(50)HF 2½”(65)SF 3”(80)RB

WARNING
 THE FLOAT ARM MUST BE FITTED ABSOLUTELY VERTICALLY (IN THE OPEN POSITION) AS INDICATED BY THE SPIRIT LEVEL (SEE BELOW). MISALIGNMENT WILL PREVENT THE VALVE FROM CLOSING.
 ENSURE OVERFLOW LEVEL IS NOT LOWER THAN 225MM FROM THE CENTRE LINE OF THE VALVE.
 THE WARNING PIPE AND OVERFLOW OUTLET SHOULD ALWAYS BE ABOVE THE HIGHEST WATER LEVEL ACHIEVED BEFORE THE VALVE CLOSURES.

HIGHEST WATER LEVEL SETTING

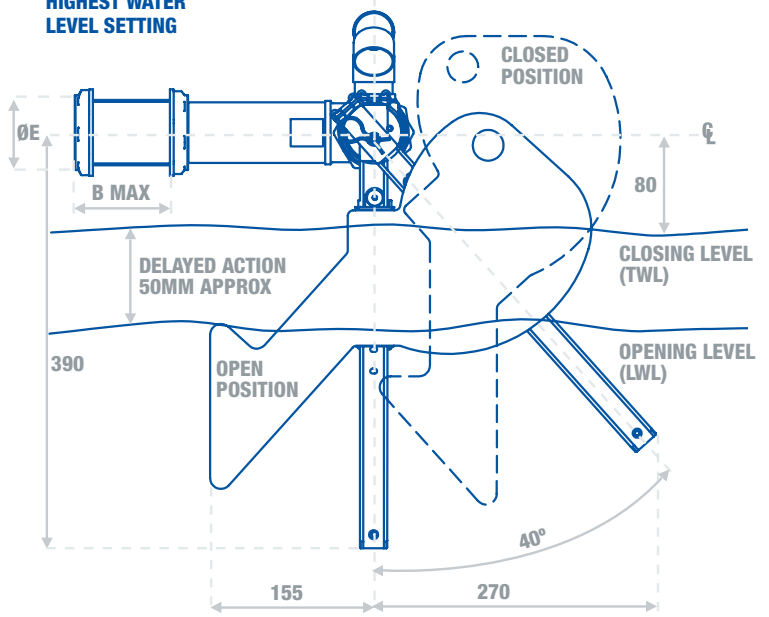

LOWEST WATER LEVEL SETTING

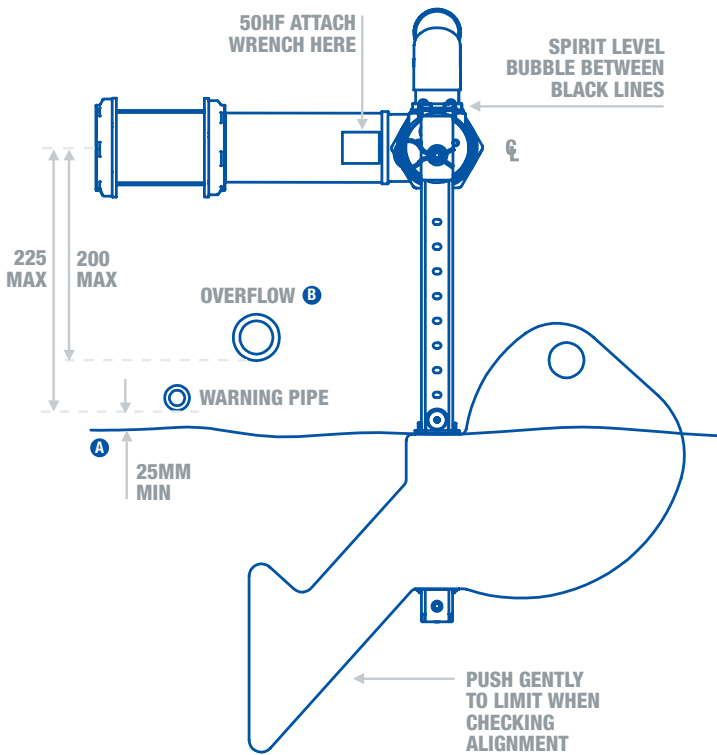
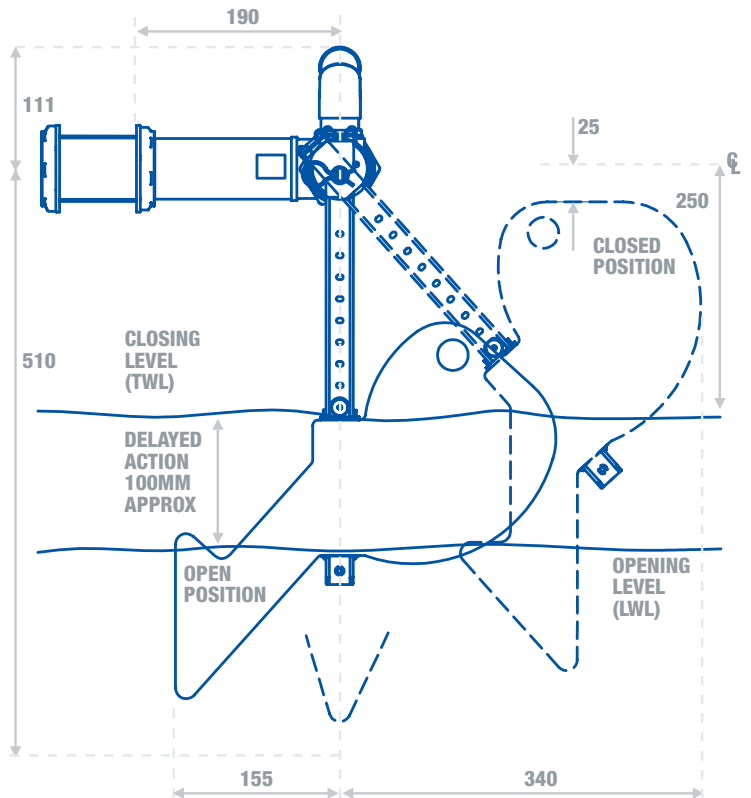

NOTES:

A SCHD2, SECT 7, G16.5 Water Regs. Gaps should be more if water is turbulent – especially if near valve discharge.

B sh
 Se

DN	50HF	65SF	80RB
SIZE	2”	2½”	3”



THORNE & DERRICK INTERNATIONAL

Thorne & Derrick
 +44 (0) 191 490 1547
 www.heatingandprocess.com