

Level detection in liquids

Capacitive

VEGACAP 62
VEGACAP 63
VEGACAP 64
VEGACAP 66
VEGACAP 69

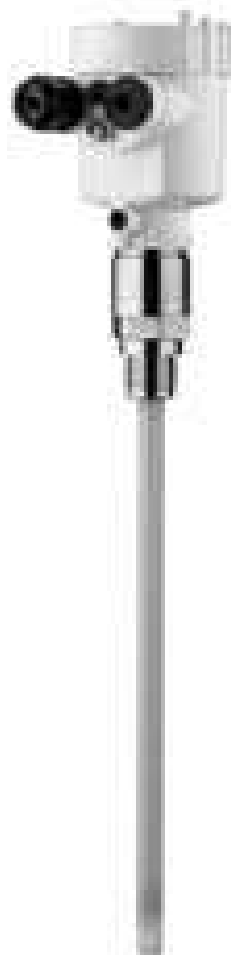

Product Information



Thorne & Derrick
+44 (0) 191 490 1547
www.heatingandprocess.com

VEGA

Content

1 Description of the measuring principle	3
2 Type overview	5
3 Mounting instructions.	7
4 Electrical connection	
4.1 Preparing the connection	9
4.2 Wiring plan	9
5 Operation	
5.1 Adjustment, general	11
6 Technical data	12
7 Dimensions.	17
8 Product code	19

Take note of safety instructions for Ex applications



Please note the Ex specific safety information which you can find on our homepage www.vega.com/services/downloads and which comes with every instrument. In hazardous areas you should take note of the appropriate regulations, conformity and type approval certificates of the sensors and power supply units. The sensors must only be operated on intrinsically safe circuits. The permissible electrical values are stated in the certificate.

1 Description of the measuring principle

Measuring principle

The VEGACAP series consists of capacitive sensors for level detection.

The instruments are designed for industrial use in all areas of process technology and are universally applicable.

Probe, measured product and vessel wall form an electrical capacitor. The capacitance is influenced by three main factors.

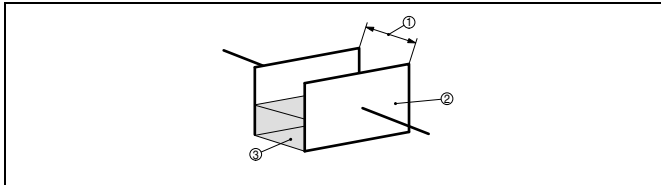

Fig. 1: Functional principle - Plate capacitor

- 1 Distance between the electrode surfaces
- 2 Size of the electrode surfaces
- 3 Type of dielectric between the electrodes

The probe and the vessel wall are the capacitor plates. The measured product is the dielectric. Due to the higher dielectric constant (DK value) of the product compared to air, the capacitance increases as the probe is gradually covered.

A level change causes a change in capacitance which is processed by the electronics and converted into an appropriate switching command.

The more constant the conductivity, concentration and temperature of a product, the better the conditions for capacitive measurement. Changes in the measuring conditions are generally less critical when detecting materials with high DK values.

The sensors are maintenance free and rugged and can be implemented in all areas of industrial measurement engineering.

Whereas partly insulated versions are predominantly used for solids, fully insulated versions are preferred for liquids.

Implementation in very adhesive or corrosive products is also no problem. Since the capacitive measuring principle places no special requirements on mounting, a host of different applications can be equipped with VEGACAP series 60 level switches.

1.1 Application examples

Non-conductive liquids

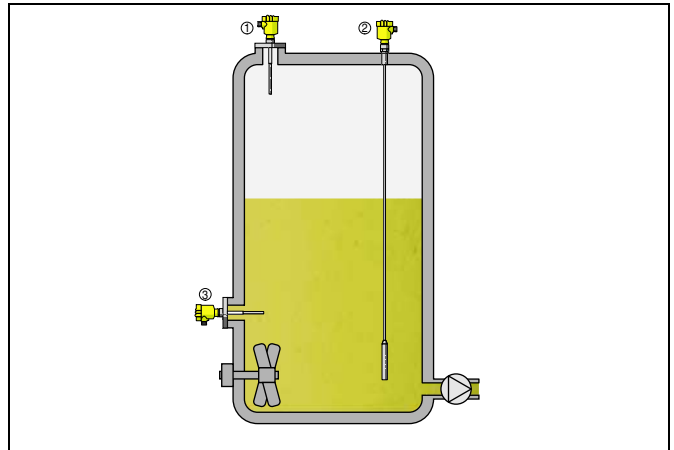

Fig. 2: Level detection in non-conductive liquids

- 1 VEGACAP 62 level switch for full signalling/overflow protection
- 2 VEGACAP 66 level switch for empty signalling/dry run protection
- 3 VEGACAP 62 level switch for level detection - laterally mounted

Capacitive level switches have proven themselves for application in non-conductive liquids (dielectric value < 5). They are used as overflow protection systems (WHG) as well as dry run protection systems. The mounting position is arbitrary (from above, laterally or from below). Typical products are hydrocarbons or solvents.

Laterally mounted or applied with an angled probe from above, the instrument switches reliably and very precisely, even in changing products. When mounted from above, the switching point can be changed afterwards and adapted to the application. By compensating its own inherent capacitance, the instrument is able to detect products with dielectric values > 1.5 reliably.

Advantages:

- Insensitive to buildup
- Overflow protection/Dry run protection
- Maintenance-free
- Very precise when mounted laterally or used with angled probe

Conductive liquids

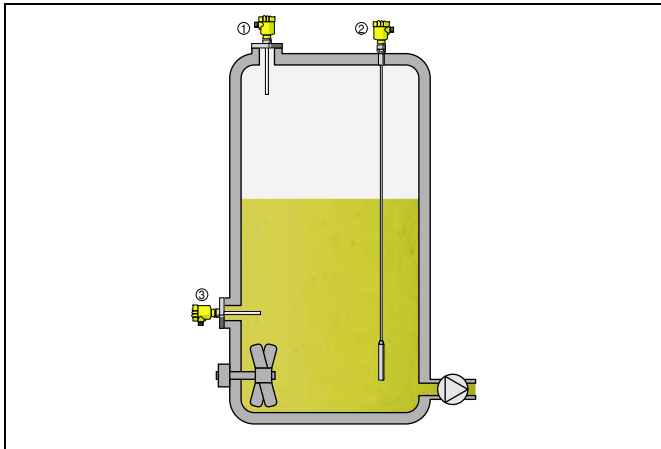

Fig. 3: Level detection in conductive liquids

- 1 VEGACAP 63 level switch for full signalling/overflow protection
- 2 VEGACAP 66 level switch for empty signalling/dry run protection
- 3 VEGACAP 63 level switch for level detection - laterally mounted

As a rule, fully insulated probes are used in conductive liquids and products with a dielectric value > approx. 5.

If the switching point must be very precise, we recommend lateral mounting - a horizontally mounted rod gets covered quickly over its entire length and has a much more reliable switching function.

To achieve an extremely accurate switching point, a partly insulated probe can be implemented. When the level reaches the set limit, the sensor generates a short circuit and thus provides a reliable, reproducible signal.

Advantages:

- Chemically highly resistant materials
- Maintenance-free
- Plated flanges
- Easy setup

Conductive, adhesive liquids

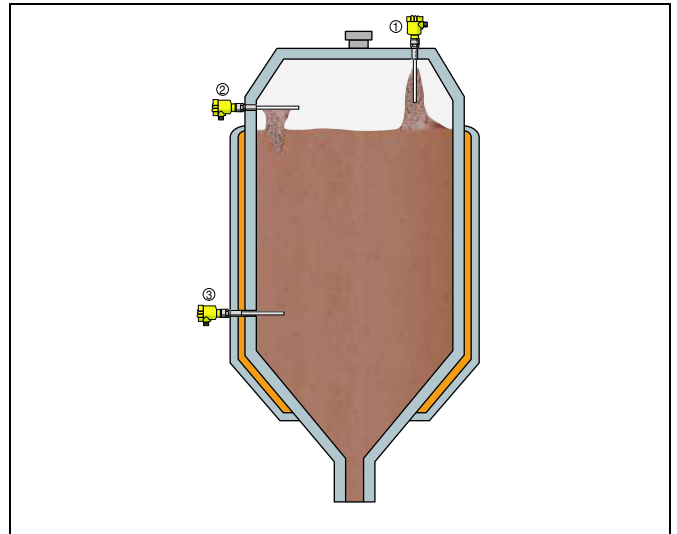

Fig. 4: Level detection in non-conductive, adhesive liquids

- 1 VEGACAP 63 level switch for full signalling/overflow protection
- 2 VEGACAP 64 level switch for full signalling/overflow protection - laterally mounted
- 3 VEGACAP 64 level switch for empty signalling/dry run protection - laterally mounted

The capacitive level switch VEGACAP 64 is particularly suitable for lateral installation as overflow and dry run protection in adhesive, conductive products. Due to the mechanical construction with active screening segment and active measuring tip, buildup several centimeters thick does not influence the measuring result. Pinpoint switching accuracy is always ensured.

If bridging on the process fittings can be precluded through vertical installation, the configuration with active screen segment is not necessary. For vertical installation in such adhesive products, a fully insulated VEGACAL 63 rod probe is sufficient as overflow protection.

Advantages:

- Insensitive to buildup
- Easy setup
- Maintenance-free
- Rugged construction
- Chemically highly resistant materials

2 Type overview

VEGACAP 62



Preferred application:	Liquids Non-conductive
Version:	Rod - partly insulated
Insulation:	PTFE
Length:	0.2 ... 6 m (0.656 ... 19.69 ft)
Process fitting:	Thread from G $\frac{3}{4}$ A, flanges
Process temperature:	-50 ... +200 °C (-58 ... +392 °F)
Process pressure:	-1 ... 64 bar/-100 ... 6400 kPa (-14.5 ... 928 psi)

VEGACAP 63



Preferred application:	Liquids Conductive
Version:	Rod - fully insulated
Insulation:	PTFE
Length:	0.2 ... 6 m (0.656 ... 19.69 ft)
Process fitting:	Thread from G $\frac{3}{4}$ A, flanges
Process temperature:	-50 ... +200 °C (-58 ... +392 °F)
Process pressure:	-1 ... 64 bar/-100 ... 6400 kPa (-14.5 ... 928 psi)

VEGACAP 64



Preferred application:	Liquids Conductive
Version:	Rod - fully insulated
Insulation:	PTFE
Length:	0.2 ... 4 m (0.656 ... 13.12 ft)
Process fitting:	Thread from G $\frac{3}{4}$ A, flanges
Process temperature:	-50 ... +200 °C (-58 ... +392 °F)
Process pressure:	-1 ... 64 bar/-100 ... 6400 kPa (-14.5 ... 928 psi)

VEGACAP 66



Preferred application:	Solids, liquids
Version:	Cable - insulated
Insulation:	PTFE
Length:	0.4 ... 32 m (1.312 ... 104.99 ft)
Process fitting:	Thread from G $\frac{3}{4}$ A, flanges
Process temperature:	-50 ... +200 °C (-58 ... +392 °F)
Process pressure:	-1 ... 64 bar/-100 ... 6400 kPa (-14.5 ... 928 psi)

VEGACAP 69



Preferred application:	Liquids
Version:	Double rod - fully insulated
Insulation:	FEP
Length:	0.2 ... 4 m (0.656 ... 13.12 ft)
Process fitting:	Flange (PP or PTFE)
Process temperature:	-40 ... +100 °C (-40 ... +212 °F)
Process pressure:	-1 ... 2 bar/-100 ... 200 kPa (-14.5 ... 29 psi)

Housing



Plastic



Stainless steel



Aluminium

Electronics



Relay output



Transistor output



Contactless electronic switch



Two-wire output

Sensors



Probe

Approvals



Gas-explosion protection



Dust-explosion protection

3 Mounting instructions

Switching point

VEGACAP can be mounted in any position.

In case of horizontal installation, the instrument must be mounted in such a way that the probe is at the height of the requested switching point.

In case of vertical installation, the instrument must be mounted so that the probe is immersed approx. 50 ... 100 mm in the product when the desired switching point is reached.

Socket

In adhesive products, the probe should protrude into the vessel (horizontal mounting), to avoid buildup. In such cases, avoid sockets for flanges and threaded fittings.

Measuring range

Please note that with fully insulated cable probes, measurement in the area of the gravity weight is not possible (L - length of the gravity weight).

With fully insulated rod probes, measurement is not possible within the 20 mm of the probe tip (L - 20 mm).

If necessary, use a correspondingly longer meas. probe.

Filling opening

Install the meas. probe in such a way that the probe does not protrude directly into the filling stream. Should such an installation location be necessary, mount a suitable baffle above or in front of the probe.

Agitators

Due to agitators, equipment vibration or similar, the probe can be subjected to strong lateral forces. For this reason, do not use an overly long probe with VEGACAP, but check if you can mount a VEGACAP level switch on the side of the vessel in horizontal position.

Excessive system vibration or shocks, e.g. caused by agitators or turbulence in the vessel (e.g. from fluidisation) can cause the probe of VEGACAP to vibrate in resonance. This can lead to increased material stress. Should a longer rod probe be necessary, you can provide a suitable support or guy directly above the end of the probe to stabilise it.

Bare probes must have an insulated support, fully insulated ones can have a bare metallic support.

Inflowing medium

If VEGACAP is mounted into the filling stream, this can cause unwanted false measurements. Therefore mount VEGACAP at a position in the vessel where no disturbances, e.g. from filling openings, agitators, etc., can occur.

This applies particularly to instrument versions with a longer probe.

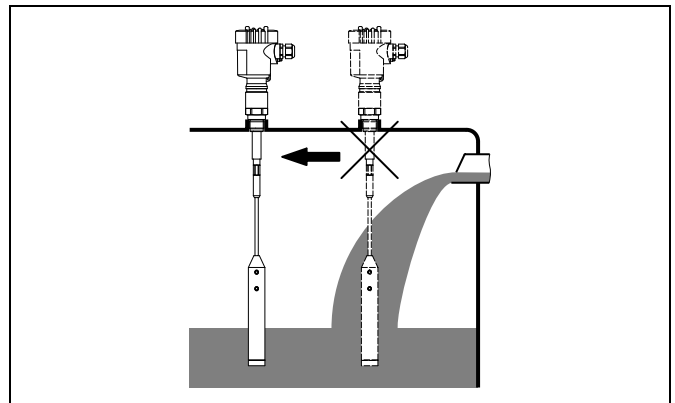

Fig. 5: Inflowing medium

Pressure/Vacuum

The process fitting must be sealed if there is gauge or low pressure in the vessel. Check if the seal material is resistant against the measured product and the process temperature.

Insulating measures in metal vessels such as e.g. covering the thread with teflon tape can interrupt the necessary electrical connection to the vessel. Ground the probe on the vessel.

Length of the level detection probe

Keep in mind when ordering the instrument that when the switching point is reached the probe must be sufficiently immersed according to the desired filling level, and that the depth of immersion depends on the electrical properties (DK value) of the medium. An electrode for level detection in oil ($\epsilon_r \sim 2$) requires a considerably deeper immersion than one used in water ($\epsilon_r \sim 81$).

As a rule:

- non-conductive products > 50 mm
- conductive products > 30 mm

Lateral load

Make sure that the probe is not subjected to strong lateral forces. Mount the probe at a position in the vessel where no interfering influence, e.g. from agitators, filling opening etc. can occur. This applies particularly to very long rod and cable probes.

Product movement

Mount the probe in such a way that the probe cannot touch the vessel wall and that the screening tube cannot be bent or broken.

Metal vessel

Make sure that the mechanical connection of the probe to the vessel is electrically conductive to ensure sufficient grounding.

Use conductive seals such as e.g. copper, lead etc.

Insulating measures such as e.g. covering the thread with teflon tape can interrupt the necessary electrical connection. If this is necessary, use the ground terminal on the housing to connect the instrument with the vessel.

Non-conductive vessels

In non-conductive vessels, e.g. plastic tanks, the second pole of the capacitor must be provided separately. Use a double rod electrode.

When using a standard probe, this can be e.g. the metal supporting structure of the vessel.

It might be necessary to attach a suitable grounding surface. Attach a very wide grounding surface outside on the vessel wall, e.g. wire braiding laminated into the vessel wall or a metal foil glued to the outside of the vessel.

Connect the grounding surface to the ground terminal on the housing.

Rod probes

Install rod probes in such a way that the probe projects freely into the vessel. When the instrument is mounted in a tube or socket, buildup can form which impairs the measurement. This applies mainly to adhesive products.

Influencing factors

In practice, the dielectric value is subject to certain fluctuations. The following factors can influence of the capacitive measuring principle:

- Concentration (mixing ratio of the product - provided it is not conductive)
- Temperature
- Conductivity (below 50 $\mu\text{S}/\text{cm}$)

The more constant the above mentioned factors, the better the conditions for capacitive measurement. Changes in the conditions are generally not critical in products with high dielectric values.

If a very precise switching point is required, or if the the product changes or has a low low dielectric value, we recommend lateral mounting - a horizontally mounted rod gets covered quickly over its entire length and has a much more reliable switching function.

You can either mount a standard measuring probe laterally or use an angled measuring probe.

Operating temperatures

If the housing is subject to high ambient temperatures, you have to either use a temperature adapter or disconnect the electronics from the probe and install it in a separate housing at a cooler place.

Make sure that the probe is not covered by an existing vessel insulation.

The temperature ranges of the probes are listed in chapter "*Technical data*".

Dielectric figure (DK value)

In products with low dielectric value and slight level changes you should try to increase the capacitance change. If the dielectric value is less than 1.5, special measures are necessary to ensure that the level is detected reliably. E.g. additional surfaces can be attached or a screening tube used with high sockets, etc.

For applications with high sockets and products with low dielectric value you can compensate the strong influence of the metal socket with a concentric tube.

Electrically conductive products react like products with very high dielectric value.

A detailed list with dielectric values is available on our homepage under "*Services - Downloads- Lists of measured products*".

Corrosive, abrasive products

Various isolating materials are available for very corrosive or abrasive products. If metal is not chemically resistant to the medium, use a plated flange.

4 Electrical connection

4.1 Preparing the connection

Note safety instructions

Always keep in mind the following safety instructions:

- Connect only in the complete absence of line voltage

Take note of safety instructions for Ex applications



In hazardous areas you should take note of the appropriate regulations, conformity and type approval certificates of the sensors and power supply units.

Select power supply

Connect the power supply according to the following diagrams. Oscillators with relay output and contactless electronic switch are designed in protection class 1. To maintain this protection class, it is absolutely necessary that the ground conductor be connected to the internal ground terminal. Take note of the general installation regulations. As a rule, connect VEGACAP to vessel ground (PA), or in case of plastic vessels, to the next ground potential. On the side of the housing there is a ground terminal between the cable entries. This connection serves to drain off electrostatic charges. In Ex applications, the installation regulations for hazardous areas must be given priority.

The data for voltage supply are specified in chapter "Technical data".

Selecting connection cable

VEGACAP is connected with standard cable with round cross section. An outer cable diameter of 5 ... 9 mm (0.2 ... 0.35 in) ensures the seal effect of the cable gland.

If cable with a different diameter or wire cross section is used, exchange the seal or use an appropriate cable connection.



In hazardous areas, only use approved cable connections for VEGACAP.

Select connection cable for Ex applications



Take note of the corresponding installation regulations for Ex applications.

4.2 Wiring plan

Relay output

We recommend connecting VEGACAP in such a way that the switching circuit is open when there is a level signal, line break or failure (safe condition).

The relays are always shown in non-operative condition.

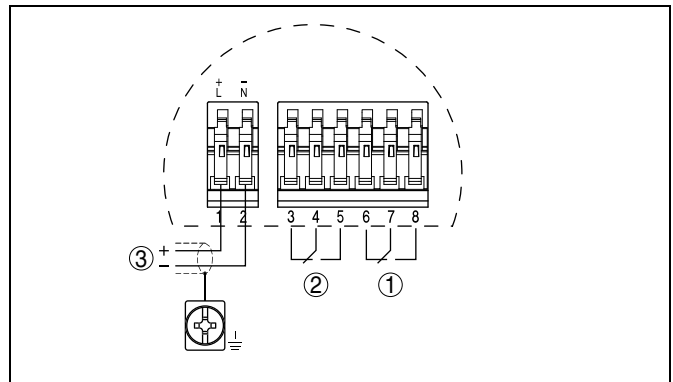

Fig. 6: Wiring plan, single chamber housing

- 1 Relay output
- 2 Relay output
- 3 Voltage supply

Transistor output

We recommend connecting VEGACAP in such a way that the switching circuit is open when there is a level signal, line break or failure (safe condition).

The instrument is used to control relays, contactors, magnet valves, warning lights, horns as well as PLC inputs.

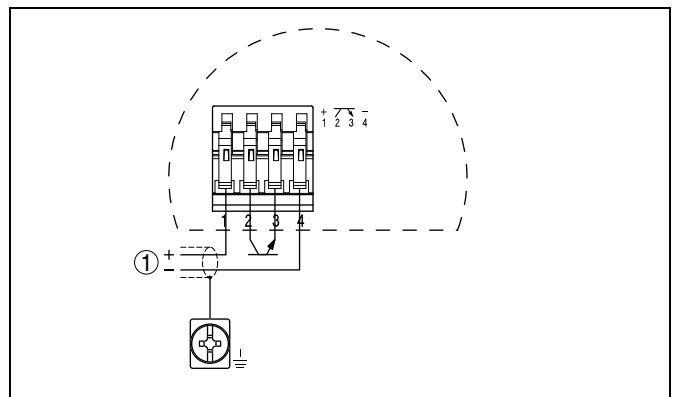

Fig. 7: Wiring plan, single chamber housing

- 1 Voltage supply

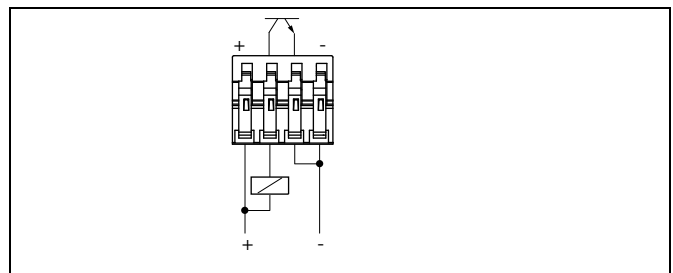

Fig. 8: NPN action

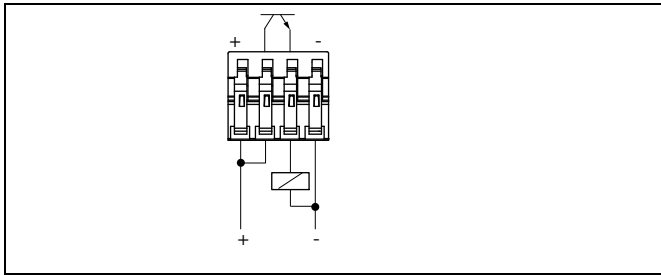

Fig. 9: PNP action

Contactless electronic switch

We recommend connecting VEGACAP in such a way that the switching circuit is open when there is a level signal, line break or failure (safe condition).

The contactless electronic switch is always shown in non-operative condition.

The instrument is used for direct control of relays, contactors, magnet valves, warning lights, horns etc. It must not be operated without an intermediately connected load, because the electronics would be destroyed if connected directly to the mains. It is not suitable for connection to low voltage PLC inputs.

Domestic current is temporarily lowered below 1 mA after switching off the load so that contactors, whose holding current is lower than the constant domestic current of the electronics, are reliably switched off.

When VEGACAP is used as part of an overfill protection system according to WHG, also note the regulations of the general type approval.

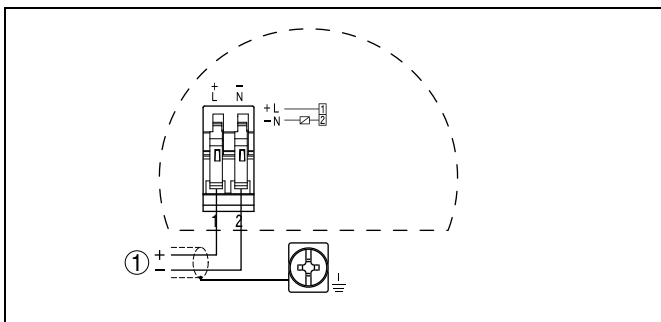

Fig. 10: Wiring plan, single chamber housing

1 Voltage supply

Two-wire output

We recommend connecting VEGACAP in such a way that the switching circuit is open when there is a level signal, line break or failure (safe condition).

For connection to a VEGATOR signal conditioning instrument dto. Ex. The sensor is powered by the connected VEGATOR signal conditioning instrument. Further information is available in chapter "Technical data", "Ex-technical data" are available in the supplied "Safety information manual".

The wiring example is applicable for all suitable signal conditioning instruments.

Take note of the operating instructions manual of the signal conditioning instrument. Suitable signal conditioning instruments are listed in chapter "Technical data".

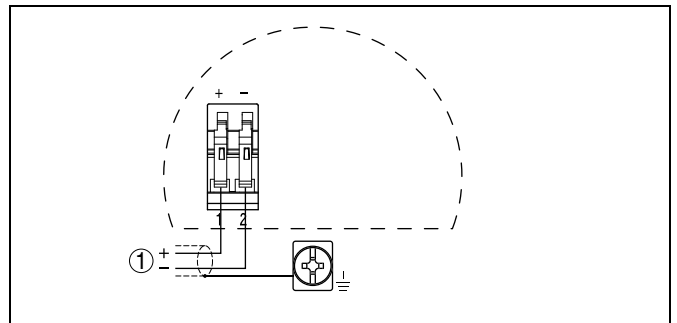

Fig. 11: Wiring plan, single chamber housing

1 Voltage supply

5 Operation

5.1 Adjustment, general

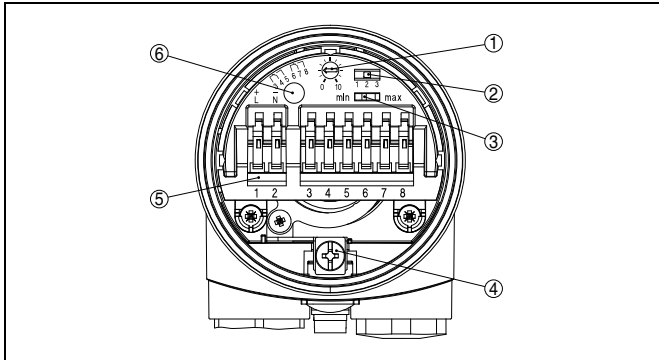

Fig. 12: Adjustment elements electronics module, e.g. relay output (CP60R)

- 1 Potentiometer for switching point adaptation (not with two-wire electronics)
- 2 Range switch
- 3 DIL switch for mode adjustment (not with two-wire electronics)
- 4 Ground terminal
- 5 Connection terminals
- 6 Control lamp

Switching point adaptation (1)

By using the potentiometer you can adapt the switching point of VEGACAP to the medium.

With two-wire electronics the switching point is adjusted on the signal conditioning instrument. For that reason there is no potentiometer.

Range switch (2)

Select the capacitance range of the probe with the mode switch.

With the potentiometer (1) and the mode switch (2) you can change the switching point of the probe or adapt the sensitivity of the probe to the electrical properties of the product and the conditions in the vessel.

This is required to enable the level switch to reliably detect products with very low or very high dielectric value reliably (DK = dielectric value).

Capacitance range

- Range 1: 0 ... 20 pF (sensitive)
- Range 2: 0 ... 85 pF
- Range 3: 0 ... 450 pF (insensitive)

Examples of dielectric values: air = 1, oil = 2, acetone = 20, water = 81 etc.

Turn the potentiometer (1) anticlockwise to make the probe more sensitive.

Mode adjustment (3)

With the mode adjustment (min./max.) you can change the switching condition of the output. You can set the required mode (max. - max. detection or overflow protection, min. - min. detection or dry run protection).

With two-wire electronics the mode is selected on the signal conditioning instrument. For that reason there is no mode switch.

LED display (6)

Diode for indication of the switching status (with plastic housing visible from outside).

6 Technical data

General data

Material 316L corresponds to 1.4404 or 1.4435

VEGACAP 62

Materials, wetted parts

– Process fitting - thread	316L
– Process fitting - flange	316L
– Process seal	Klingsil C-4400
– insulation (partly insulated)	PTFE
– Electrode (rod PTFE partly insulated: \varnothing 12 mm/0.472 in)	316L

Materials, non-wetted parts

– Housing	Plastic PBT (polyester), Alu die-casting powder-coated, 316L
– Seal between housing and housing cover	NBR (stainless steel housing), silicone (Alu/plastic housing)
– Ground terminal	316L

Weight

– Instrument weight	1 ... 3 kg (2.2 ... 6.6 lbs)
– Rod weight: \varnothing 12 mm (0.472 in)	900 g/m (10 oz/ft)
– Sensor length (L)	0.1 ... 6 m (0.328 ... 19.69 ft)
– Max. lateral load	10 Nm (7.4 lbf ft)
– Max. torque (process fitting - thread)	100 Nm (73 lbf ft)

VEGACAP 63

Materials, wetted parts

– Process fitting - thread	316L
– Process fitting - flange	316L
– Process seal	Klingsil C-4400
– insulation (fully insulated)	PTFE, PE
– Probe (rod fully insulated: \varnothing 16 mm/0.63 in)	316L

Materials, non-wetted parts

– Housing	Plastic PBT (polyester), Alu die-casting powder-coated, 316L
– Seal between housing and housing cover	NBR (stainless steel housing), silicone (Alu/plastic housing)
– Ground terminal	316L

Weight

– Instrument weight	1 ... 3 kg (2.2 ... 6.6 lbs)
– Rod weight: \varnothing 16 mm (0.63 in)	1100 g/m (12 oz/ft)
– Sensor length (L)	0.1 ... 6 m (0.328 ... 19.69 ft)
– Max. lateral load	10 Nm (7.4 lbf ft)
– Max. torque (process fitting - thread)	100 Nm (73 lbf ft)

VEGACAP 64

Materials, wetted parts

– Process fitting - thread	316L
– Process fitting - flange	316L
– Process seal	Klingsil C-4400
– insulation (fully insulated)	PTFE
– Probe (rod PTFE fully insulated: \varnothing 16 mm/0.63 in)	316L

Materials, non-wetted parts

– Housing	Plastic PBT (polyester), Alu die-casting powder-coated, 316L
– Seal between housing and housing cover	NBR (stainless steel housing), silicone (Alu/plastic housing)
– Ground terminal	316L

Weight

– Instrument weight	1 ... 3 kg (2.2 ... 6.6 lbs)
– Rod weight: \varnothing 16 mm (0.63 in)	1100 g/m (12 oz/ft)
– Sensor length (L)	0.2 ... 6 m (0.656 ... 19.69 ft)
– Max. lateral load	10 Nm (7.4 lbf ft)
– Max. torque (process fitting - thread)	100 Nm (73 lbf ft)

VEGACAP 66

Materials, wetted parts

– Process fitting - thread	316L
– Process fitting - flange	316L
– Process seal	Klingsil C-4400
– insulation (fully insulated)	PTFE
– Probe (cable PTFE fully insulated: \varnothing 8 mm/0.315 in)	316L

Materials, non-wetted parts	
– Housing	Plastic PBT (polyester), Alu die-casting powder-coated, 316L
– Seal between housing and housing cover	NBR (stainless steel housing), silicone (Alu/plastic housing)
– Ground terminal	316L
Weight	
– Instrument weight	1 ... 3 kg (2.2 ... 6.6 lbs)
– Cable weight: \varnothing 8 mm (0.315 in)	200 g/m (2.1 oz/ft)
– Sensor length (L)	0.4 ... 32 m (1.312 ... 104.99 ft)
– Max. tensile load (cable)	10 KN (2248 lbs)
– Max. torque (process fitting - thread)	100 Nm (73 lbf ft)

VEGACAP 69

Materials, wetted parts	
– Process fitting - flange	PP or PTFE
– insulation (fully insulated)	FEP
Materials, non-wetted parts	
– Probe - double rod fully insulated: \varnothing 14 mm (0.551 in)	316L
– Housing	Plastic PBT (polyester), Alu die-casting powder-coated, 316L
– Seal between housing and housing cover	NBR (stainless steel housing), silicone (Alu/plastic housing)
– Ground terminal	316L
Weight¹⁾	
– Instrument weight	0.8 ... 4 kg (0.18 ... 8.82 lbs)
– Rod weight: \varnothing 14 mm (0.551 in)	2000 g/m (22 oz/ft)
– Sensor length (L)	0.2 ... 4 m (0.656 ... 13.12 ft)
– Max. lateral load	10 Nm (7.4 lbf ft)
– Frequency	430 kHz

Output variable

Relay output

Output	Relay output (DPDT), 2 floating spdts
Turn-on voltage	
– Min.	10 mV
– Max.	253 V AC, 253 V DC
Switching current	
– Min.	10 μ A
– Max.	3 A AC, 1 A DC
Breaking capacity	
– Max.	1250 VA, 50 W
– Min.	50 mW
– Contact material (relay contacts)	AgCdO and Au plated
– Modes (adjustable)	min./max.
Integration time approx.	
– When immersed	0.5 s
– When laid bare	0.5 s
– In case of failure	1 s

Transistor output

Output	floating transistor output, overload and permanently shortcircuit proof
– Max. load current	400 mA
– Max. turn-on voltage	55 V DC
– Blocking current	< 100 μ A
– Modes (adjustable)	min./max.
Integration time approx.	
– When immersed	0.5 s
– When laid bare	0.5 s
– In case of failure	1 s

Contactless electronic switch

Output	Contactless electronic switch
– Modes (adjustable)	min./max.

¹⁾ Flange weight not considered.

Integration time approx.

- When immersed 0.5 s
- When laid bare 0.5 s
- In case of failure 1 s

Two-wire output

Output	Two-wire output
Suitable signal conditioning instruments	VEGATOR 521, 527, 620, 621, 622
Modes	adjustable via the signal conditioning instrument
Output signal	> 4 ... < 20 mA (not standardised)
Fault message	< 2.3 mA
Integration time approx.	
- When immersed	0.5 s
- When laid bare	0.5 s
- In case of failure	1 s

Ambient conditions

Ambient temperature on the housing	-40 ... +80 °C (-40 ... +176 °F)
Storage and transport temperature	-40 ... +80 °C (-40 ... +176 °F)

Process conditions

Process pressure	The max. permissible pressure and max. permissible temperature depend on the process fitting used.
- VEGACAP 62, 63, 64, 66	-1 ... 64 bar/-100 ... 6400 kPa (-14.5 ... 928 psi)
- VEGACAP 69	-1 ... 2 bar/-100 ... 200 kPa (-14.5 ... 29 psi)
Process temperature	
- VEGACAP 62 - PTFE insulation (partly insulated)	-50 ... +150 °C (-58 ... +302 °F)
- VEGACAP 62 - temperature adapter (option)	-50 ... +200 °C (-58 ... +392 °F)
- VEGACAP 63 - PE insulation	-40 ... +80 °C (-40 ... +176 °F)
- VEGACAP 63 - PTFE insulation	-50 ... +150 °C (-58 ... +302 °F)
- VEGACAP 63 - temperature adapter (option)	-50 ... +200 °C (-58 ... +392 °F)
- VEGACAP 64 - PTFE insulation	-50 ... +150 °C (-58 ... +302 °F)
- VEGACAP 64 - temperature adapter (option)	-50 ... +200 °C (-58 ... +392 °F)
- VEGACAP 66 - PTFE insulation	-50 ... +150 °C (-58 ... +302 °F)
- VEGACAP 66 - temperature adapter (option)	-50 ... +200 °C (-58 ... +392 °F)

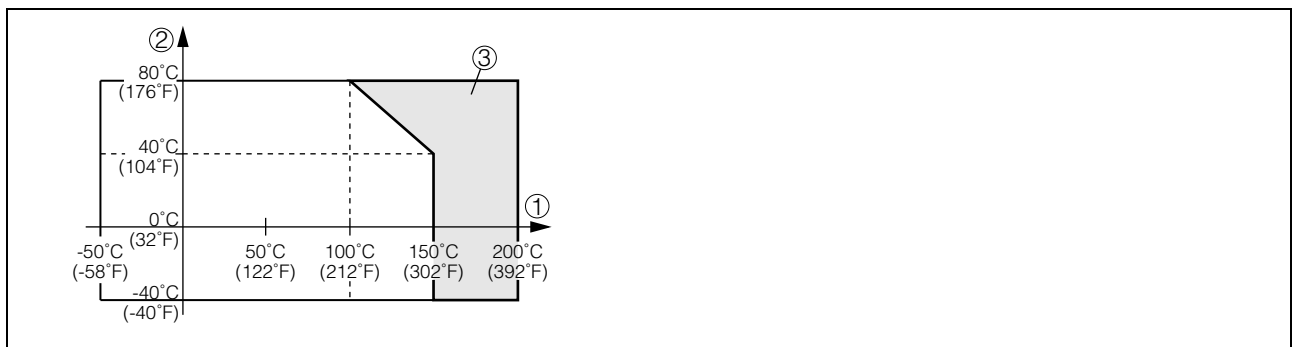

Fig. 13: VEGACAP 62, 63, 64, 66 - ambient temperature - product temperature

- 1 Product temperature
- 2 Ambient temperature
- 3 Temperature range with temperature adapter



Fig. 14: VEGACAP 69 - process pressure - Process temperature (flange of PP)

- 1 Process pressure
- 2 Process temperature

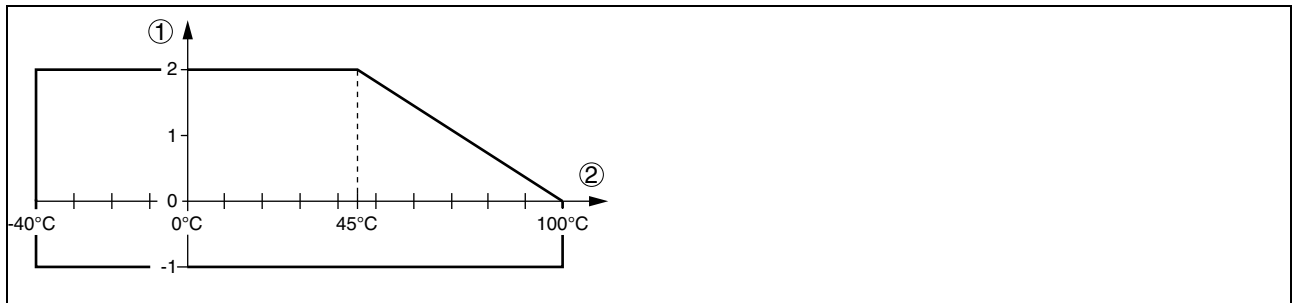

Fig. 15: VEGACAP 69 - process pressure - Process temperature (flange of PTFE)

- 1 Process pressure
- 2 Process temperature

Dielectric figure > 1.5

Electromechanical data

Cable entry/plug (dependent on the version)

– Single chamber housing

- 1 x cable entry M20 x 1.5 (cable: \varnothing 5 ... 9 mm), 1 x blind stopper M20 x 1.5; attached 1 x cable entry M20 x 1.5
- or:
- 1 x cable entry 1/2 NPT, 1 x blind stopper 1/2 NPT, 1 x cable entry 1/2 NPT
- or:
- 1 x plug M12 x 1; 1 x blind stopper M20 x 1.5

Spring-loaded terminals

for wire cross-section up to 1.5 mm² (AWG 16)

Adjustment elements

Mode switch (not with two-wire electronics)

- Min.
- Max.

Min. detection or dry run protection
Max. detection or overflow protection

Meas. range switch

- range 1
- range 2
- range 3

0 ... 20 pF (sensitive)
0 ... 85 pF
0 ... 450 pF (insensitive)

– Fault message

< 2.3 mA

Switching point adjustment

Potentiometer (not with two-wire electronics)

Voltage supply

Relay output (R)

Supply voltage

20 ... 253 V AC, 50/60 Hz, 20 ... 72 V DC (at U > 60 V DC, the ambient temperature can be max. 50 °C/122 °F)

Power consumption

1 ... 8 VA (AC), approx. 1 W (DC)

Transistor output (T)

Supply voltage	10 ... 55 V DC
Max. power consumption	0.5 W

Contactless electronic switch (C)

Supply voltage	20 ... 253 V AC, 50/60 Hz, 20 ... 253 V DC
Domestic current requirement	approx. 3 mA (via load circuit)
Load current	
– Min.	10 mA
– Max.	400 mA (at I > 300 mA the ambient temperature can be max. 60 °C/140 °F) max. 4 A up to 40 ms

Two-wire output (Z)

Supply voltage	10 ... 36 V DC (via the signal conditioning instrument)
----------------	---

Electrical protective measures**Electronics versions - relay output, contactless electronic switch**

Protection	IP 66/IP 67
Overvoltage category	III
Protection class	I

Electronics versions - transistor output, two-wire output

Protection	IP 66/IP 67
Overvoltage category	III
Protection class	II

Approvals²⁾**Electronics versions - relay, transistor output, contactless electronic switch**

Overfill protection according to WHG

ATEX

– ATEX II 1/2D 2D IP6X T

Ship approvals

Electronics version - two-wire output

Overfill protection according to WHG

ATEX

– ATEX II 1G, 1/2G, 2G EEx ia IIC T6

– ATEX II 1/2D 2D IP6X T

IEC

– IEC Ex ia IIC T6

FM

– FM (NI) CL I, DIV2, GP ABCD (DIP) CL II, III, DIV1, GP EFG

Ship approvals

CE conformity

EMVG (89/336/EWG), Emission: EN 61326: 2004 (class B),

Susceptibility: EN 61326: 2004 (Supplement A)

LVD (73/23/EWG), EN 61010-1: 2001

²⁾ Deviating data in Ex applications: see separate safety instructions.

7 Dimensions

Housing

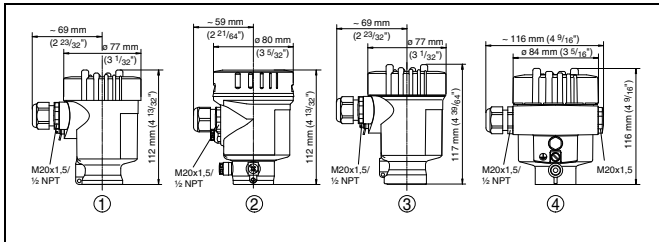

Fig. 16: Housing versions

- 1 Plastic housing
- 2 Stainless steel housing
- 3 Stainless steel housing - precision casting
- 3 Aluminium housing

VEGACAP 62

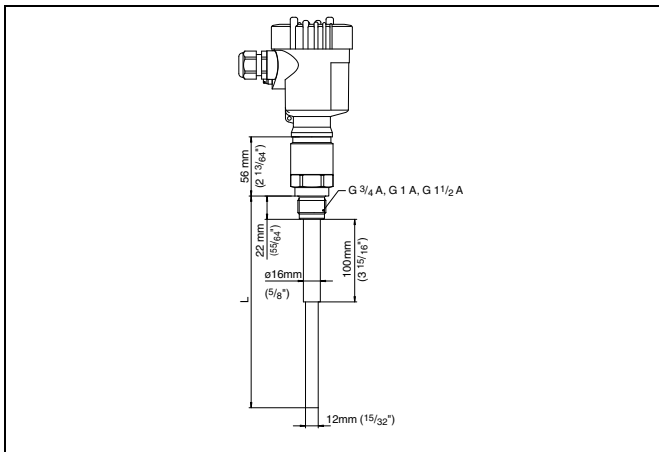

Fig. 17: VEGACAP 62 - threaded version

L Sensor length, see chapter "Technical data"

VEGACAP 63

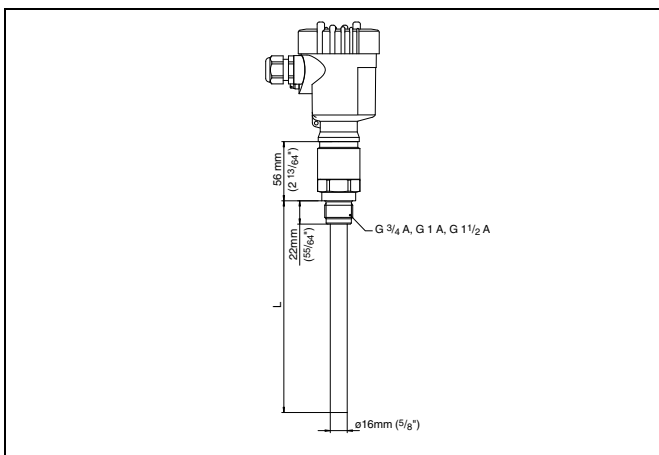

Fig. 18: VEGACAP 63 - threaded version

L Sensor length, see chapter "Technical data"

VEGACAP 64

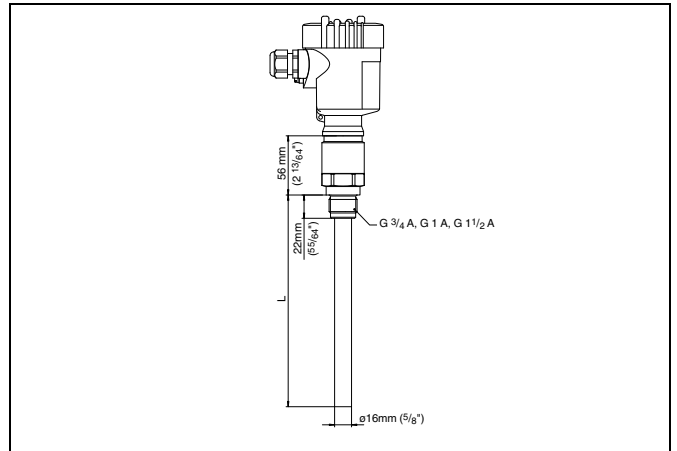

Fig. 19: VEGACAP 64 - threaded version

L Sensor length, see chapter "Technical data"

VEGACAP 66

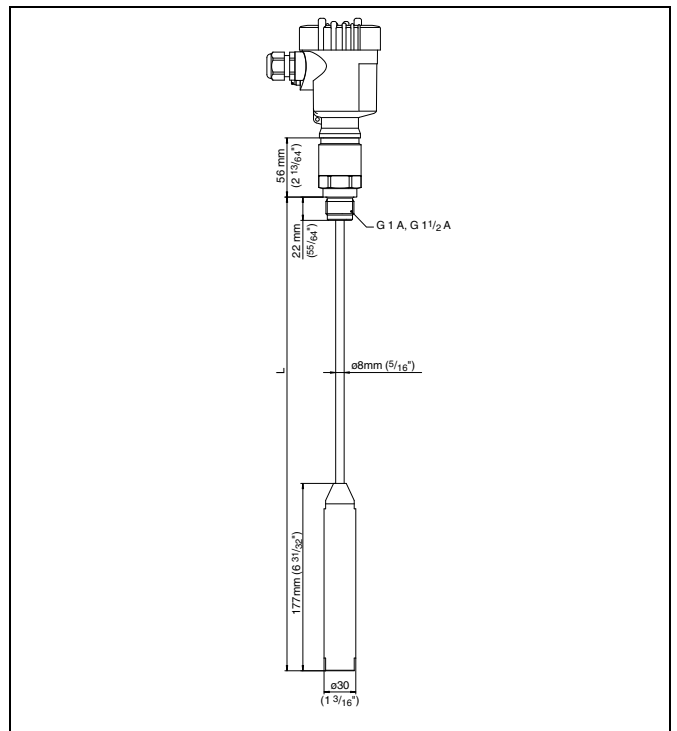

Fig. 20: VEGACAP 66 - threaded version

L Sensor length, see chapter "Technical data"

VEGACAP 69

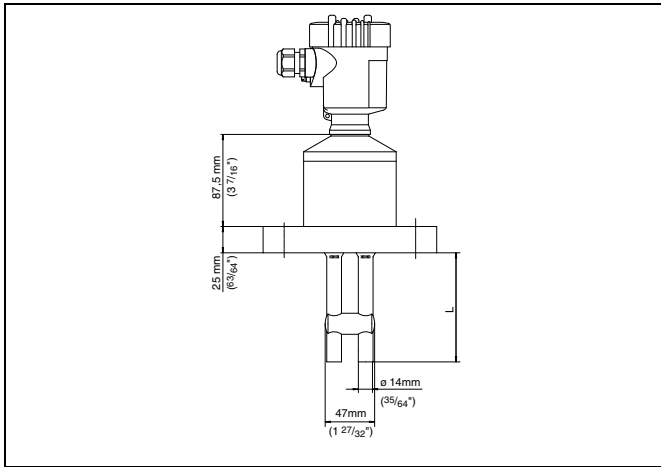
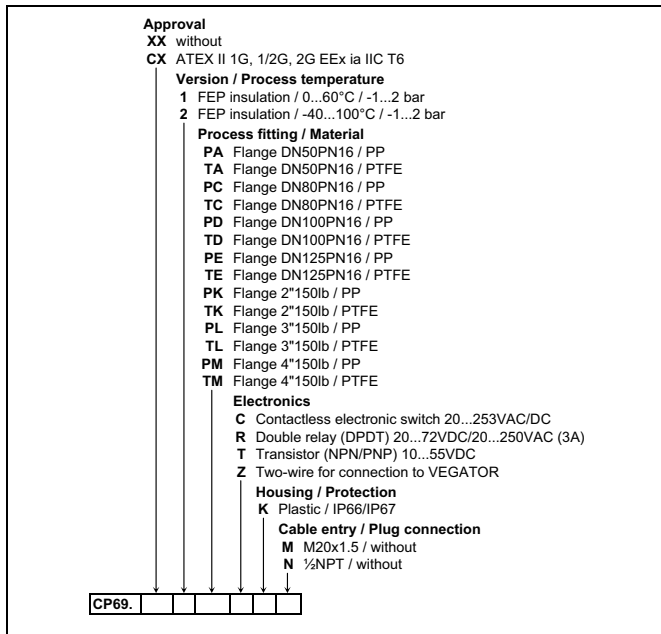

Fig. 21: VEGACAP 69

L Sensor length, see chapter "Technical data"

VEGACAP 69





VEGA



VEGA Grieshaber KG



Thorne & Derrick
+44 (0) 191 490 1547 ^m
www.heatingandprocess.com ^{als}

- certificates
- approvals
- and much, much more