

Operating Instructions

Capacitive rod electrode for level
detection

VEGACAP 64

- contactless electronic switch



Document ID: 30013



VEGA

Contents

1	About this document	
1.1	Function	4
1.2	Target group	4
1.3	Symbols used.....	4
2	For your safety	
2.1	Authorised personnel	5
2.2	Appropriate use.....	5
2.3	Warning about incorrect use.....	5
2.4	General safety instructions	5
2.5	Safety label on the instrument	6
2.6	CE conformity.....	6
2.7	Safety instructions for Ex areas	6
2.8	Environmental instructions	6
3	Product description	
3.1	Configuration.....	7
3.2	Principle of operation.....	8
3.3	Operation	9
3.4	Packaging, transport and storage.....	9
3.5	Accessories and replacement parts	10
4	Mounting	
4.1	General instructions	11
4.2	Mounting instructions	12
5	Connecting to power supply	
5.1	Preparing the connection	14
5.2	Connection procedure.....	14
5.3	Wiring plan, single chamber housing.....	15
6	Setup	
6.1	General information.....	18
6.2	Adjustment elements.....	18
6.3	Function table.....	21
7	Maintenance and fault rectification	
7.1	Maintenance	22
7.2	Rectify faults.....	22
7.3	Exchange of the electronics module.....	23
7.4	How to proceed if a repair is necessary.....	25
8	Dismount	
8.1	Dismounting steps.....	26
8.2	Disposal	26
9	Supplement	
9.1	Technical data	27
9.2	Dimensions	30
9.3	Industrial property rights.....	33
9.4	Trademark	33

Supplementary documentation



Information:

Supplementary documents appropriate to the ordered version come with the delivery. You can find them listed in chapter "*Product description*".

Instructions manuals for accessories and replacement parts



Tip:

To ensure reliable setup and operation of your VEGACAP 64, we offer accessories and replacement parts. The corresponding documentations are:

- 30174 - Electronics module VEGACAP series 60
- 34296 - Protective cover
- 31088 - Flanges according to DIN-EN-ASME-JIS-GOST

Editing status: 2016-02-19

1 About this document

1.1 Function

This operating instructions manual provides all the information you need for mounting, connection and setup as well as important instructions for maintenance and fault rectification. Please read this information before putting the instrument into operation and keep this manual accessible in the immediate vicinity of the device.

1.2 Target group

This operating instructions manual is directed to trained specialist personnel. The contents of this manual should be made available to these personnel and put into practice by them.

1.3 Symbols used



Information, tip, note

This symbol indicates helpful additional information.



Caution: If this warning is ignored, faults or malfunctions can result.



Warning: If this warning is ignored, injury to persons and/or serious damage to the instrument can result.



Danger: If this warning is ignored, serious injury to persons and/or destruction of the instrument can result.



Ex applications

This symbol indicates special instructions for Ex applications.



SIL applications

This symbol indicates instructions for functional safety which must be taken into account particularly for safety-relevant applications.



List

The dot set in front indicates a list with no implied sequence.



Action

This arrow indicates a single action.



Sequence of actions

Numbers set in front indicate successive steps in a procedure.



Battery disposal

This symbol indicates special information about the disposal of batteries and accumulators.

2 For your safety

2.1 Authorised personnel

All operations described in this operating instructions manual must be carried out only by trained specialist personnel authorised by the plant operator.

During work on and with the device the required personal protective equipment must always be worn.

2.2 Appropriate use

The VEGACAP 64 is a sensor for point level detection.

You can find detailed information about the area of application in chapter "*Product description*".

Operational reliability is ensured only if the instrument is properly used according to the specifications in the operating instructions manual as well as possible supplementary instructions.

For safety and warranty reasons, any invasive work on the device beyond that described in the operating instructions manual may be carried out only by personnel authorised by the manufacturer. Arbitrary conversions or modifications are explicitly forbidden.

2.3 Warning about incorrect use

Inappropriate or incorrect use of the instrument can give rise to application-specific hazards, e.g. vessel overfill or damage to system components through incorrect mounting or adjustment.

2.4 General safety instructions

This is a state-of-the-art instrument complying with all prevailing regulations and guidelines. The instrument must only be operated in a technically flawless and reliable condition. The operator is responsible for the trouble-free operation of the instrument.

During the entire duration of use, the user is obliged to determine the compliance of the necessary occupational safety measures with the current valid rules and regulations and also take note of new regulations.

The safety instructions in this operating instructions manual, the national installation standards as well as the valid safety regulations and accident prevention rules must be observed by the user.

For safety and warranty reasons, any invasive work on the device beyond that described in the operating instructions manual may be carried out only by personnel authorised by the manufacturer. Arbitrary conversions or modifications are explicitly forbidden.

The safety approval markings and safety tips on the device must also be observed.

2.5 Safety label on the instrument

The safety approval markings and safety tips on the device must be observed.

2.6 CE conformity

This device fulfills the legal requirements of the applicable EC guidelines. By attaching the CE mark, VEGA provides a confirmation of successful testing. You can find the CE conformity declaration in the download area of "www.vega.com".

2.7 Safety instructions for Ex areas

Please note the Ex-specific safety information for installation and operation in Ex areas. These safety instructions are part of the operating instructions manual and come with the Ex-approved instruments.

2.8 Environmental instructions

Protection of the environment is one of our most important duties. That is why we have introduced an environment management system with the goal of continuously improving company environmental protection. The environment management system is certified according to DIN EN ISO 14001.

Please help us fulfill this obligation by observing the environmental instructions in this manual:

- Chapter "*Packaging, transport and storage*"
- Chapter "*Disposal*"

3 Product description

3.1 Configuration

Scope of delivery

The scope of delivery encompasses:

- VEGACAP 64 point level switch
- Documentation
 - This operating instructions manual
 - Safety Manual "*Functional safety (SIL)*" (optional)
 - Supplementary instructions manual "*Plug connector for level sensors*" (optional)
 - Ex-specific "*Safety instructions*" (with Ex versions)
 - If necessary, further certificates

Constituent parts

The VEGACAP 64 consists of the components:

- Process fitting with probe
- Housing with electronics
- Housing cover, optionally available with display and adjustment module

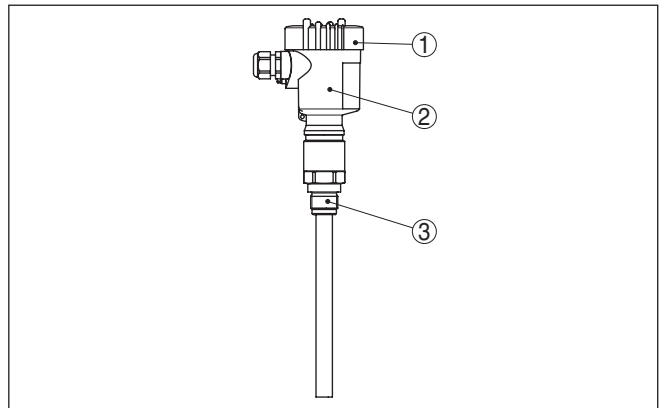

Fig. 1: VEGACAP 64 - rod version with plastic housing

- 1 Housing cover with integrated display and adjustment module (optional)
- 2 Housing with electronics
- 3 Process fitting

Type label

The type label contains the most important data for identification and use of the instrument:

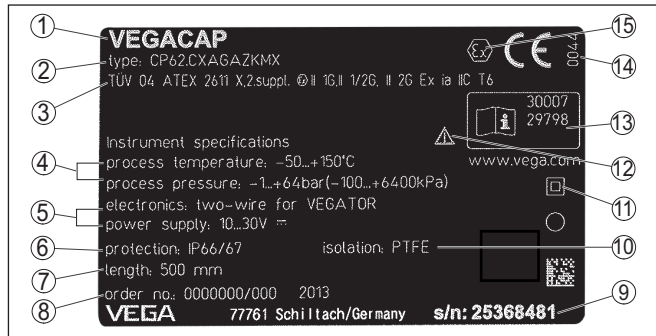

Fig. 2: Layout of the type label (example)

- 1 Instrument type
- 2 Product code
- 3 Approvals
- 4 Process and ambient temperature, process pressure
- 5 Power supply and signal output, electronics
- 6 Protection rating
- 7 Probe length
- 8 Order number
- 9 Serial number of the instrument
- 10 Material, wetted parts
- 11 Symbol of the device protection class
- 12 Reminder to observe the instrument documentation
- 13 ID numbers, instrument documentation
- 14 Notified authority for CE marking
- 15 Approval directives

With the serial number, you can access the delivery data of the instrument via www.vega.com, "VEGA Tools" and "serial number search". You can find the serial number on the inside of the instrument as well as on the type label on the outside.

3.2 Principle of operation

Area of application

VEGACAP 64 is a point level sensor for use in non-abrasive liquids and bulk solids.

The rod probe is fully insulated and due to its construction is suitable for all viscous and adhesive products.

Functional principle

Probe, measured product and vessel wall form an electrical capacitor. The capacitance is influenced by three main factors.

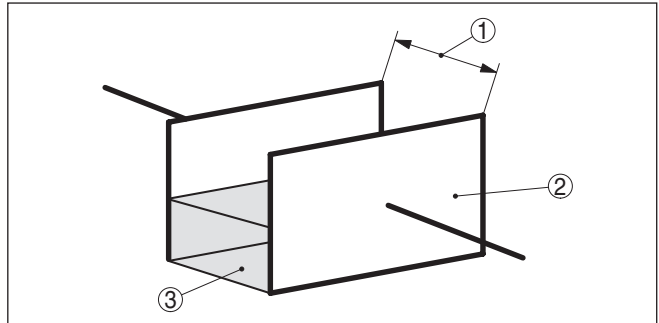

Fig. 3: Functional principle - Plate capacitor

- 1 Distance between the electrode surfaces
- 2 Size of the electrode surfaces
- 3 Type of dielectric between the electrodes

The probe and the vessel wall are the capacitor plates. The measured product is the dielectric. Due to the higher dielectric constant of the product compared to air, the capacitance increases as the probe is gradually covered.

The capacitance change is converted by the electronics module into a switching command.

Voltage supply

VEGACAP 64 is a compact instrument, i.e. it can be operated without external evaluation system. The integrated electronics evaluates the level signal and outputs a switching signal. With this switching signal, a connected device can be operated directly (e.g. a warning system, a pump etc.).

The data for power supply are specified in chapter "*Technical data*".

3.3 Operation

The probe can be adapted to the dielectric constant of the product directly on the electronics module.

A switching command can be triggered when the probe is covered or laid bare.

On the electronics module you will find the following display and adjustment elements:

- Signal lamp for indication of the switching condition (green/red)
- Potentiometer for switching point adaptation
- DIL switch for measuring range selection
- DIL switch for mode adjustment

3.4 Packaging, transport and storage

Your instrument was protected by packaging during transport. Its capacity to handle normal loads during transport is assured by a test based on ISO 4180.

The packaging of standard instruments consists of environment-friendly, recyclable cardboard. For special versions, PE foam or PE

foil is also used. Dispose of the packaging material via specialised recycling companies.

Transport

Transport must be carried out in due consideration of the notes on the transport packaging. Nonobservance of these instructions can cause damage to the device.

Transport inspection

The delivery must be checked for completeness and possible transit damage immediately at receipt. Ascertained transit damage or concealed defects must be appropriately dealt with.

Storage

Up to the time of installation, the packages must be left closed and stored according to the orientation and storage markings on the outside.

Unless otherwise indicated, the packages must be stored only under the following conditions:

- Not in the open
- Dry and dust free
- Not exposed to corrosive media
- Protected against solar radiation
- Avoiding mechanical shock and vibration

Storage and transport temperature

- Storage and transport temperature see chapter "*Supplement - Technical data - Ambient conditions*"
- Relative humidity 20 ... 85 %

3.5 Accessories and replacement parts

Protective cap

The protective cover protects the sensor housing against soiling and intense heat from solar radiation.

You will find additional information in the supplementary instructions manual "*Protective cover*" (Document-ID 34296).

Flanges

Screwed flanges are available in different versions according to the following standards: DIN 2501, EN 1092-1, BS 10, ASME B 16.5, JIS B 2210-1984, GOST 12821-80.

You can find additional information in the supplementary instructions manual "*Flanges according to DIN-EN-ASME-JIS*".

4 Mounting

4.1 General instructions

Suitability for the process conditions	<p>Make sure that all parts of the instrument coming in direct contact with the process, especially the sensor element, process seal and process fitting, are suitable for the existing process conditions, such as process pressure, process temperature as well as the chemical properties of the medium.</p> <p>You can find the specifications in chapter "<i>Technical data</i>" and on the nameplate.</p>
Switching point	<p>In general the level switch can be mounted in any position. The instrument must be mounted in such a way that the probe is at the height of the requested switching point.</p>
Welding work	<p>Before beginning the welding work, remove the electronics module from the sensor. By doing this, you avoid damage to the electronics through inductive coupling.</p> <p>Ground the probe before welding directly on the rod or cable.</p>
Handling	<p>With threaded versions, the housing must not be used to screw in the instrument. Applying tightening forces on the housing can damage its internal parts.</p> <p>Use the hexagon for screwing in.</p>
Moisture	<p>Use the recommended cables (see chapter "<i>Connecting to power supply</i>") and tighten the cable gland.</p> <p>You can give your instrument additional protection against moisture penetration by leading the connection cable downward in front of the cable entry. Rain and condensation water can thus drain off. This applies mainly to outdoor mounting as well as installation in areas where high humidity is expected (e.g. through cleaning processes) or on cooled or heated vessels.</p>

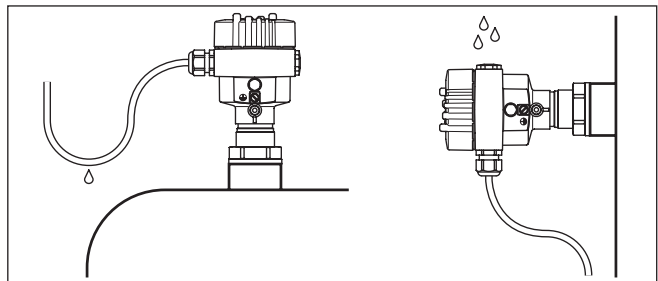

Fig. 4: Measures against moisture ingress

Transport

Do not hold VEGACAP 64 on the probe. Especially with heavy flange versions or long rod versions, the sensor can be damaged simply by the weight of the instrument.

Pressure/Vacuum

The process fitting must be sealed if there is gauge or low pressure in the vessel. Before use, check if the seal material is resistant against the measured product and the process temperature.

The max. permissible pressure is specified in chapter "*Technical data*" or on the type label of the sensor.

Vessel material**Metal vessel**

Make sure that the mechanical connection of the probe to the vessel is electrically conductive to ensure sufficient grounding.

Use conductive seals, such as those made of copper or lead, etc. Insulating measures, such as covering the thread with Teflon tape, can interrupt the necessary electrical connection with metal vessels. For this reason, ground the probe on the vessel or use a conductive seal material.

Non-conductive vessels

In non-conductive vessels, e.g. plastic tanks, the second pole of the capacitor must be provided separately.

**Cable entries - NPT thread
Cable glands****Metric threads**

In the case of instrument housings with metric thread, the cable glands are screwed in at the factory. They are sealed with plastic plugs as transport protection.

You have to remove these plugs before electrical connection.

NPT thread

In the case of instrument housings with self-sealing NPT threads, it is not possible to have the cable entries screwed in at the factory. The free openings for the cable glands are therefore covered with red dust protection caps as transport protection.

Prior to setup you have to replace these protective caps with approved cable glands or close the openings with suitable blind plugs.

4.2 Mounting instructions**Agitators and fluidization**

Due to the effects of agitators, equipment vibration or similar, the level switch can be subjected to strong lateral forces. For this reason, do not use an overly long electrode for VEGACAP 64, but check if you can mount a short level switch on the side of the vessel in horizontal position.

Extreme vibration caused by the system, e.g. due to agitators or turbulence in the vessel from fluidisation, can cause the probe of VEGACAP 64 to vibrate in resonance. If a longer rod version is necessary, you can secure the probe by fastening a suitable brace or guy directly above the end of the rod.

Inflowing medium

If the instrument is mounted in the filling stream, unwanted false measurement signals can be generated. For this reason, mount the instrument at a position in the vessel where no disturbances, e.g. from filling openings, agitators, etc., can occur.

This applies particularly to instrument versions with a longer probe.

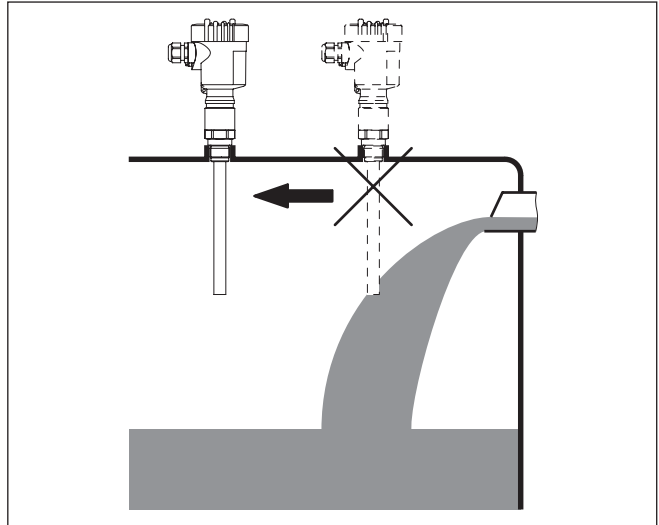

Fig. 5: Inflowing medium

Torque with PTFE plated flanges

To compensate the normal voltage loss due to sealing materials, you have to additionally use disc springs for fastening flange screws on PTFE coated flanges. Tighten the screws moderately with the torque stated in the technical data.

5 Connecting to power supply

5.1 Preparing the connection

Note safety instructions

Always keep in mind the following safety instructions:



Warning:

Connect only in the complete absence of line voltage.

- The electrical connection must only be carried out by trained personnel authorised by the plant operator.
- Always switch off power supply, before connecting or disconnecting the instrument.



Note:

Install a separating facility for the instrument which is easy to access. The separating facility must be marked for the instrument (IEC/EN 61010).

Voltage supply

Connect mains voltage according to the connection diagrams. Take note of the general installation regulations. The electronics module CP60C is designed in protection class I. To maintain this protection class, it is absolutely necessary that the ground conductor be connected to the internal ground conductor terminal. Take note of the corresponding installation regulations for Ex applications.

The data for power supply are specified in chapter "*Technical data*".

Connection cable

The instrument is connected with standard three-wire cable without screen. If electromagnetic interference is expected which is above the test values of EN 61326 for industrial areas, screened cable should be used.

Use cable with round cross-section. A cable outer diameter of 5 ... 9 mm (0.2 ... 0.35 in) ensures the seal effect of the cable gland. If you are using cable with a different diameter or cross-section, exchange the seal or use a suitable cable gland.

5.2 Connection procedure



With Ex instruments, the housing cover may only be opened if there is no explosive atmosphere present.

Proceed as follows:

1. Unscrew the housing lid
2. Loosen compression nut of the cable gland and remove blind plug
3. Remove approx. 10 cm (4 in) of the cable mantle, strip approx. 1 cm (0.4 in) of insulation from the ends of the individual wires
4. Insert the cable into the sensor through the cable entry
5. Lift the opening levers of the terminals with a screwdriver (see following illustration)
6. Insert the wire ends into the open terminals according to the wiring plan

7. Press down the opening levers of the terminals, you will hear the terminal spring closing
 8. Check the hold of the wires in the terminals by lightly pulling on them
 9. Tighten the compression nut of the cable entry gland. The seal ring must completely encircle the cable
 10. If necessary, carry out a fresh adjustment
 11. Screw the housing lid back on
- The electrical connection is finished.

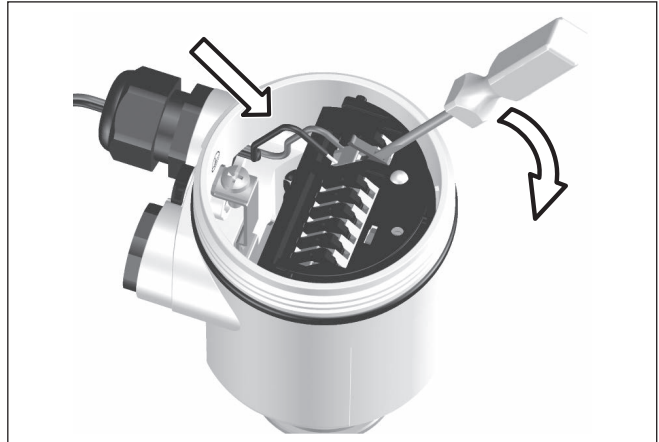

Fig. 6: Connection steps 5 and 6

5.3 Wiring plan, single chamber housing

Housing overview

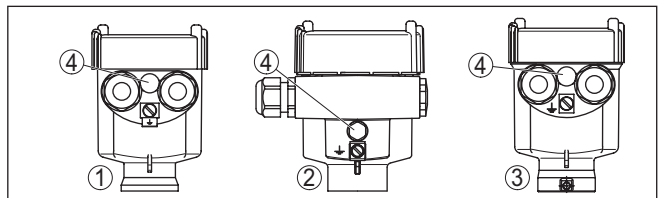

Fig. 7: Material versions, single chamber housing

- 1 Plastic (not with dust-Ex)
- 2 Aluminium
- 3 Stainless steel
- 4 Filter element for air pressure compensation

Electronics and terminal compartment

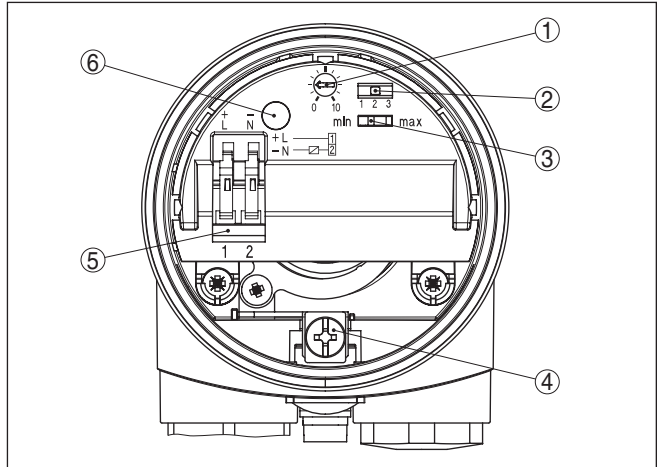

Fig. 8: Electronics and terminal compartment

- 1 Potentiometer for switching point adaptation
- 2 DIL switch for measuring range selection
- 3 DIL switch for mode adjustment
- 4 Ground terminal
- 5 Connection terminals
- 6 Control lamp

Wiring plan

We recommend connecting VEGACAP 64 in such a way that the switching circuit is open when there is a level signal, line break or failure (safe state).

The contactless electronic switch is always shown in non-operative condition.



Warning:

The instrument must not be operated without an intermediately connected load, because the electronics would be destroyed if connected directly to the mains. It is not suitable for connection to low voltage PLC inputs.

Examples for typical applications:

- Load resistance at 24 V DC: 88 ... 1800 Ω
- Rated power, relay 253 V AC: > 2.5 VA
- Rated power, relay 24 V AC: > 0.5 VA

For direct control of relays, contactors, magnet valves, warning lights, horns etc.

Domestic current is temporarily lowered below 1 mA after switching off the load so that contactors, whose holding current is lower than the constant domestic current of the electronics, are reliably switched off.

When VEGACAP 64 is used as part of an overfill protection system according to WHG, also note the regulations of the general type approval.

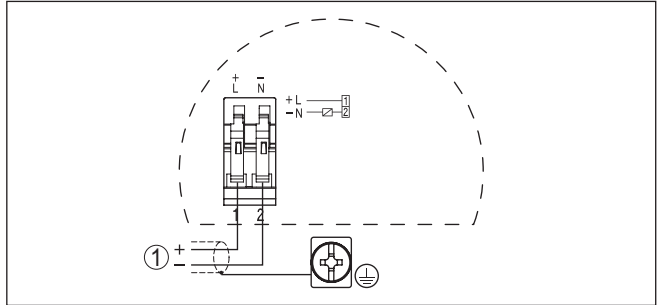

Fig. 9: Wiring plan

1 Voltage supply

6 Setup

6.1 General information

The figures in brackets refer to the following illustrations.

Function/Configuration

On the electronics module you will find the following display and adjustment elements:

- Potentiometer for switching point adaptation
- DIL switch for measuring range selection
- DIL switch for mode adjustment - min./max.
- Control lamp



Note:

As a rule, always set the mode with the mode switch (3) before starting setup VEGACAP 64. The switching output will change if you set the mode switch (3) afterwards. This could possibly trigger other connected instruments or devices.

6.2 Adjustment elements

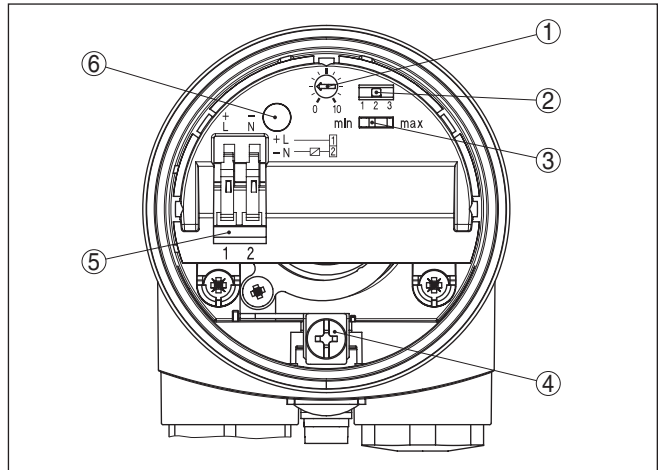

Fig. 10: Oscillator - Contactless electronic switch

- 1 Potentiometer for switching point adaptation
- 2 DIL switch for measuring range selection (with compensation button)
- 3 DIL switch for mode adjustment
- 4 Ground terminal
- 5 Connection terminals
- 6 Control lamp

The switching status of the electronics can be checked with closed housing (only plastic housing), see "Function table".



Note:

Screw the housing cover tightly up to the thread stop so that the inspection glass is above the control lamp (LED).

To adjust VEGACAP 64, first of all remove the housing cover.

Switching point adaptation (1)

You can adapt the switching point to the solid with the potentiometer.

Measuring range selection switch (2)

With the potentiometer (1) and the measuring range selection switch (2) you can change the sensitivity of the probe to the electrical properties of the product and the conditions in the vessel. This is necessary so that the level switch can also reliably detect products e.g. with very low or very high dielectric figure.

range 1: 0 ... 20 pF

Range 2: 0 ... 85 pF

Range 3: 0 ... 450 pF

Mode adjustment (3)

With the mode switch (3) you can change the switching status of the output. The required mode can be set according to the function table.

max. - max. detection or overflow protection

min. - min. detection or dry run protection.

We recommend connecting according to the idle current principle (contactless electronic switch is open when the switching point is reached) because the contactless electronic switch takes on the same (safe) state if a failure is detected.

Signal lamp (6)

Control lamp for indication of the switching status.

- green = switch closed
- red = switch open
- red (flashing) = failure

Switching point adjustment

The adjustment of the switching point is only possible in installed condition.

The specifications in parenthesis refer to the preceding illustration.

Horizontally mounted probes, angled probes

Mode max. [mode min.]

1. Set mode switch (3) to mode max [min.].
2. Set meas. range selection switch (2) to range 1.
3. Make sure the probe is not covered by the medium.
4. Turn the potentiometer (1) to 0, the control lamp (6) lights red [lights green].
5. To determine the empty switch point, turn the potentiometer (1) very slowly clockwise until the control lamp lights green [lights red]. If the control lamp still lights red [lights green], then you have to set the meas. range selection switch (2) to the next higher stage and repeat the setting with the potentiometer (1) until the control lamp lights green [lights red].
6. Note the position of the potentiometer (1).

In some cases the lowest range (range 1 = highest sensitivity) is not sufficient to adjust the full switch point. This would make another filling procedure necessary.

For this reason we recommend setting and noting the empty switching point in all three meas. ranges. Set the meas. range selection switch (2) to the next higher range and repeat the setting. Also note the values for the next ranges.

7. Reset meas. range selection switch (2) to the next lower range in which the control lamp lights green [lights red].
8. Fill the vessel until the probe is completely covered.
9. Turn the potentiometer (1) very slowly clockwise until the control lamp lights green [lights red].
10. Note the position of the potentiometer (1). We recommend documenting the value of the empty switch point and the full switch point as well as the range.
11. If the control lamp does not light green [light red], then you have to set the meas. range switch (2) to the next higher stage and repeat the setting with the potentiometer until the control lamp lights green [lights red].
12. Set the potentiometer (1) to the average value of the two noted values.

The measuring system is now ready for operation.

	Empty adjustment	Full adjustment
range 1		
range 2		
range 3		

Tab. 1: Note the position of the potentiometer.



Note:

If you do not find the full switch point in one of the ranges, we recommend setting the meas. range selection switch (2) to the lowest range in which you have found the empty switch point. Set the potentiometer (1) to the average value between empty switch point and 10.

Mode max. (max. level detection)

Vertically mounted probes

1. Set mode switch (3) to mode max.
2. Set meas. range selection switch (2) to range 1.
3. Fill the vessel up to the requested level.
4. Turn potentiometer (1) to position 10.

When the control lamp (6) lights red: set the measuring range selection switch (2) to the next higher measuring range.

When the control lamp (6) lights green: continue with the next item.

5. Turn the potentiometer (1) very slowly anticlockwise until the control lamp (6) lights red.

The measuring system is now ready for operation.

1. Set mode switch (3) to mode min.
2. Set meas. range selection switch (2) to range 1.
3. Lower the level to the requested min. level.

















Mode min. (min. level detection)

4. Turn the potentiometer (1) to 0, the control lamp (6) lights green.
5. Turn the potentiometer (1) very slowly clockwise until the control lamp (6) lights red. If the control lamp does not light red, set the meas. range selection switch (2) to the next higher stage and repeat the setting with the potentiometer (1) until the control lamp lights red.

The measuring system is now ready for operation.

6.3 Function table

The following table provides an overview of the switching conditions depending on the set mode and the level.

	Level	Switching status	Control lamp
Mode max. Overflow protection		 Switch closed	 Green
Mode max. Overflow protection		 Switch open	 Red
Mode min. Dry run protection		 Switch closed	 Green
Mode min. Dry run protection		 Switch open	 Red
Failure of the supply voltage (min./max. mode)	any	 Switch open	
Fault	any	 Switch open	 flashes red

7 Maintenance and fault rectification

7.1 Maintenance

If the instrument is used properly, no special maintenance is required in normal operation.

7.2 Rectify faults

Reaction when malfunction occurs

The operator of the system is responsible for taking suitable measures to rectify faults.

Causes of malfunction

VEGACAP 64 offers maximum reliability. Nevertheless, faults can occur during operation. These may be caused by the following, e.g.:

- Sensor
- Process
- Voltage supply
- Signal processing

Fault rectification

The first measure to take is to check the output signal. In many cases, the causes can be determined this way and the faults quickly rectified.

24 hour service hotline

Should these measures not be successful, please call in urgent cases the VEGA service hotline under the phone no. **+49 1805 858550**.

The hotline is manned 7 days a week round-the-clock. Since we offer this service worldwide, the support is only available in the English language. The service is free, only standard call charges are incurred.

Checking the switching signal

Error	Cause	Rectification
– The instrument signals covered without covering with the medium	Wrong mode selected	Set the correct mode on the mode switch (max.: overfill protection, min.: dry run protection)
	Operating voltage too low	Check operating voltage
– The instrument signals covered with covering with the medium	Shortcircuit in the probe, e.g. because of moisture in the housing	Remove the electronics module. Check the resistance between the marked plug connections. See the following instructions.
	Electronics defective	<ul style="list-style-type: none"> – Push mode switch (min./max.) – If the probe then does not change the mode, the electronics module may be defective. Exchange the electronics module – If the instrument then changes the mode, the instrument is mechanically damaged. Should the switching function in the correct mode still be faulty - return the probe for repair.

Error	Cause	Rectification
Signal lamp flashes red	Electronics module has detected a failure	Exchange the instrument or send it in for repair

Check the resistance in the probe

Remove the electronics module. Check the resistance between the two plug connections.

There must no longer be a connection (high impedance). If there is still a connection - exchange the instrument or return it for repair

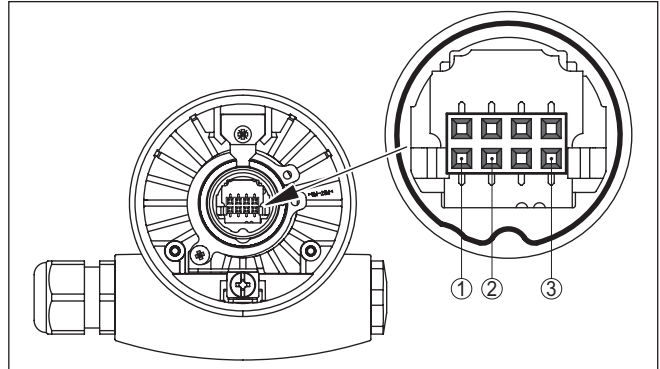

Fig. 27: Check the resistance in the probe

- 1 Shielding
- 2 Measuring probe
- 3 Ground potential

Reaction after fault rectification

Depending on the reason for the fault and the measures taken, the steps described in chapter "Set up" may have to be carried out again.

7.3 Exchange of the electronics module

In general, all electronics modules of series CP60 can be interchanged. If you want to use an electronics module with a different signal output, you can download the corresponding operating instructions manual from our homepage under Downloads.

Proceed as follows:

1. Switch off power supply
2. Unscrew the housing lid
3. Lift the opening levers of the terminals with a screwdriver
4. Pull the connection cables out of the terminals
5. Loosen the two screws with a screw driver (Torx size T10 or slot 4)

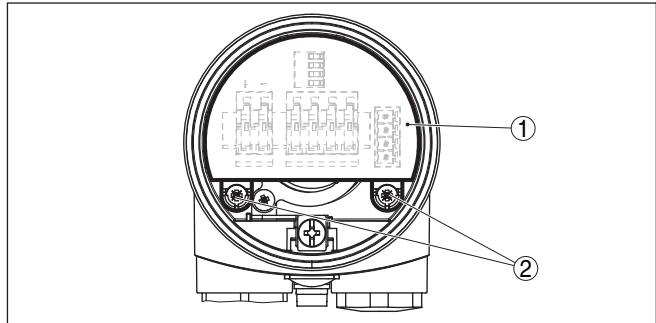

Fig. 28: Loosen the holding screws

- 1 Electronics module
- 2 Screws (2 pcs.)

6. Pull out the old electronics module
7. Compare the new electronics module with the old one. The type label of the electronics module must correspond to that of the old electronics module. This applies particularly to instruments used in hazardous areas.
8. Compare the settings of the two electronics modules. Set the adjustment elements of the new electronics module to the same setting of the old one.



Information:

Make sure that the housing is not rotated during the electronics exchange. Otherwise the plug may be in a different position later.

9. Insert the electronics module carefully. Make sure that the plug is in the correct position.
10. Screw in and tighten the two holding screws with a screwdriver (Torx size T10 or Phillips 4)
11. Insert the wire ends into the open terminals according to the wiring plan
12. Press down the opening levers of the terminals, you will hear the terminal spring closing
13. Check the hold of the wires in the terminals by lightly pulling on them
14. Check cable gland on tightness. The seal ring must completely encircle the cable.
15. Mount the probe into the vessel. Make sure that the probe is uncovered.

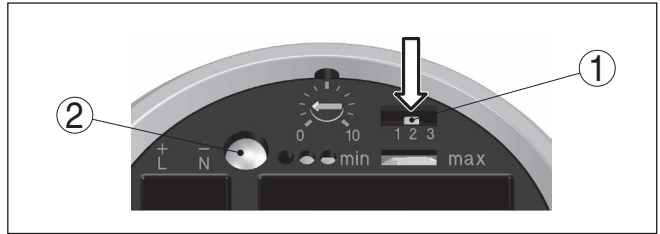

Fig. 29: Compensation key

- 1 Measuring range selection switch (compensation key)
- 2 Control lamp

16. Keep the measuring range selection switch (1) pushed until the control lamp (2) flashes green.
 17. Carry out the adjustment again. See chapter "Set-up, adjustment elements".
 18. Screw the housing lid back on
- The electronics exchange is now finished.

7.4 How to proceed if a repair is necessary

You can find an instrument return form as well as detailed information of the procedure in the download area on our homepage: www.vega.com.

By doing this you help us carry out the repair quickly and without having to call back for needed information.

If a repair is necessary, please proceed as follows:

- Print and fill out one form per instrument
- Clean the instrument and pack it damage-proof
- Attach the completed form and, if need be, also a safety data sheet outside on the packaging
- Please contact the agency serving you to get the address for the return shipment. You can find the agency on our home page www.vega.com.

8 Dismount

8.1 Dismounting steps

**Warning:**

Before dismantling, be aware of dangerous process conditions such as e.g. pressure in the vessel, high temperatures, corrosive or toxic products etc.

Take note of chapters "*Mounting*" and "*Connecting to power supply*" and carry out the listed steps in reverse order.

8.2 Disposal

The instrument consists of materials which can be recycled by specialised recycling companies. We use recyclable materials and have designed the parts to be easily separable.

WEEE directive 2002/96/EG

This instrument is not subject to the WEEE directive 2002/96/EG and the respective national laws. Pass the instrument directly on to a specialised recycling company and do not use the municipal collecting points. These may be used only for privately used products according to the WEEE directive.

Correct disposal avoids negative effects on humans and the environment and ensures recycling of useful raw materials.

Materials: see chapter "*Technical data*"

If you have no way to dispose of the old instrument properly, please contact us concerning return and disposal.

9 Supplement

9.1 Technical data

General data

Material 316L corresponds to 1.4404 or 1.4435

Materials, wetted parts

- Process fitting - thread	316L
- Process fitting - flange	316L
- Process seal	Klingsil C-4400
- insulation (fully insulated)	PTFE
- Probe (rod PTFE fully insulated: ø 16 mm/0.63 in)	316L

Materials, non-wetted parts

- Plastic housing	plastic PBT (Polyester)
- Aluminium die-casting housing	Aluminium die-casting AlSi10Mg, powder-coated - basis: Polyester
- Stainless steel housing - precision casting	316L
- Stainless steel housing, electropolished	316L
- Seal between housing and housing lid	NBR (stainless steel housing, precision casting), silicone (aluminium/plastic housing; stainless steel housing, electropolished)
- Ground terminal	316L
- Cable gland	PA, stainless steel, brass
- Sealing, cable gland	NBR
- Blind plug, cable gland	PA

Process fittings

- Pipe thread, cylindrical (DIN 3852-A)	G1, G1½
- American pipe thread, conical (ASME B1.20.1)	1 NPT, 1½ NPT
- Flanges	DIN from DN 50, ASME from 2"

Weight

- Instrument weight (depending on process fitting)	0.8 ... 4 kg (0.18 ... 8.82 lbs)
- Rod weight: ø 16 mm (0.63 in)	1100 g/m (12 oz/ft)

Sensor length (L)

- Process fitting: thread and flanges	0.15 ... 6 m (0.492 ... 19.69 ft)
- Process fitting: Flanges - PTFE plated	0.15 ... 6 m (0.492 ... 19.69 ft)

Max. lateral load 10 Nm (7.4 lbf ft)

Torque of the flange screws (min.) 60 Nm (44.25 lbf ft)

Max. torque (process fitting - thread) 100 Nm (74 lbf ft)

Torque for NPT cable glands and Conduit tubes

– Plastic housing	max. 10 Nm (7.376 lbf ft)
– Aluminium/Stainless steel housing	max. 50 Nm (36.88 lbf ft)
Measuring frequency	430 kHz

Output variable

Output	Contactless electronic switch
Modes (switchable)	Min./Max.
Switching delay	
– When immersed	0.7 s
– When laid bare	0.7 s
– In the event of a fault	1 s

Accuracy (according to DIN EN 60770-1)

Reference conditions according to DIN EN 61298-1

– Temperature	+18 ... +30 °C (+64 ... +86 °F)
– Relative humidity	45 ... 75 %
– Air pressure	860 ... 1060 mbar/86 ... 106 kPa (12.5 ... 15.4 psig)

Deviation due to strong, high-frequency electromagnetic fields acc. to EN 61326 < 3 % of the adjusted measuring range¹⁾

Influence of the ambient temperature < 0.15 %/10 K of the adjusted measuring range²⁾

Ambient conditions

Ambient temperature on the housing	-40 ... +80 °C (-40 ... +176 °F)
Storage and transport temperature	-40 ... +80 °C (-40 ... +176 °F)

Process conditions

Process pressure

– Threaded versions	-1 ... 64 bar/-100 ... 6400 kPa (-14.5 ... 928 psig), depending on the process fitting
– Flange version	-1 ... 64 bar/-100 ... 6400 kPa (-14.5 ... 928 psig), depending on the process fitting
– Flange version $\geq 3''/DN 80$, plated	-0.4 ... 64 bar/-40 ... 6400 kPa (-5.8 ... 928 psig), depending on the process fitting

Process temperature VEGACAP 64 of 316L -50 ... +150 °C (-58 ... +302 °F)

Process temperature (thread or flange temperature) with temperature adapter (option) -50 ... +200 °C (-58 ... +392 °F)

¹⁾ Distance from the process fittings to the set switching point

²⁾ Distance from the process fittings to the set switching point

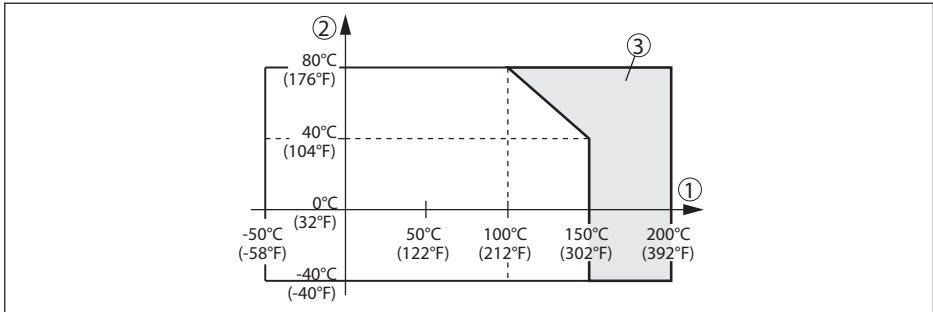

Fig. 30: Ambient temperature - Process temperature

- 1 Process temperature
- 2 Ambient temperature
- 3 Temperature range with temperature adapter

Dielectric constant ≥ 1.5

Electromechanical data

Cable entry/plug (dependent on the version)

- Single chamber housing
 - 1 x cable entry M20 x 1.5 (cable: ø 5 ... 9 mm),
1 x blind plug M20 x 1.5; attached 1 x cable entry M20 x 1.5
 - or:
 - 1 x cable entry ½ NPT, 1 x blind plug ½ NPT, 1 x cable entry ½ NPT
 - or:
 - 1 x plug M12 x 1; 1 x blind plug M20 x 1.5
- Spring-loaded terminals for wire cross-section up to 1.5 mm² (AWG 16)

Adjustment elements

Mode switch

- Min. Min. detection or dry run protection
- Max. Max. detection or overflow protection

DIL switch for measuring range selection

- range 1 0 ... 20 pF
- range 2 0 ... 85 pF
- range 3 0 ... 450 pF

Potentiometer

Switching point adaptation

Voltage supply

- Operating voltage 20 ... 253 V AC, 50/60 Hz, 20 ... 253 V DC
- Domestic current requirement approximately 3 mA (via load circuit)
- Load current
 - Min. 10 mA

30013-EN-160331

- Max. 400 mA (at $I > 300$ mA the ambient temperature can be max. 60 °C/140 °F) max. 4 A up to 40 ms

Electrical protective measures

Protection rating	IP 66/IP 67 (NEMA 4X)
Overtoltage category	III
Protection class	I

Approvals

Instruments with approvals can have different technical specifications depending on the version.

For that reason the associated approval documents of these instruments have to be carefully noted. They are part of the delivery or can be downloaded under www.vega.com, "VEGA Tools" and "Instrument search" as well as in the general download area.

9.2 Dimensions

VEGACAP 64, housing

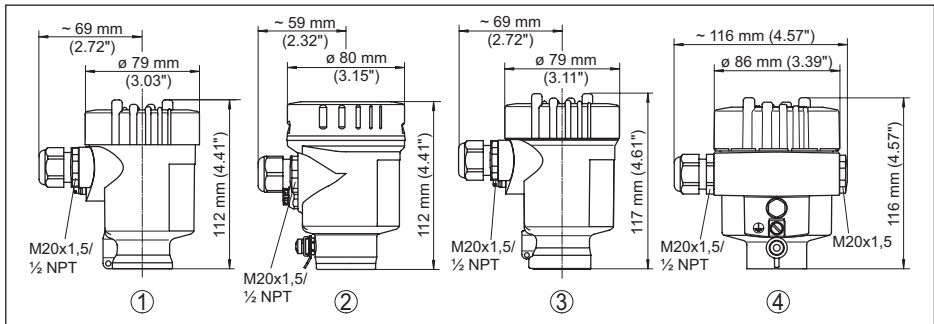

Fig. 31: Housing versions

- 1 Plastic housing
- 2 Stainless steel housing, electropolished
- 3 Stainless steel housing, precision casting
- 4 Aluminium housing

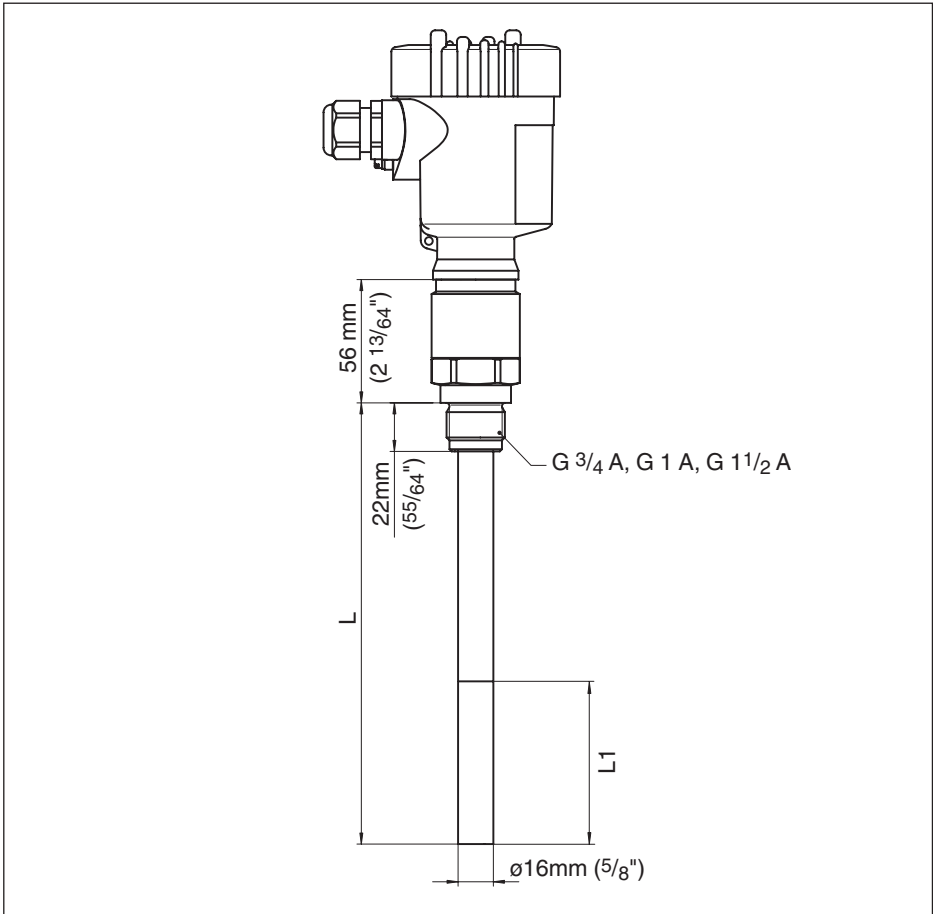

Fig. 32: VEGACAP 64, threaded version G1 (ISO 228 T1)

L = Sensor length, see chapter "Technical data"

L1 = active length

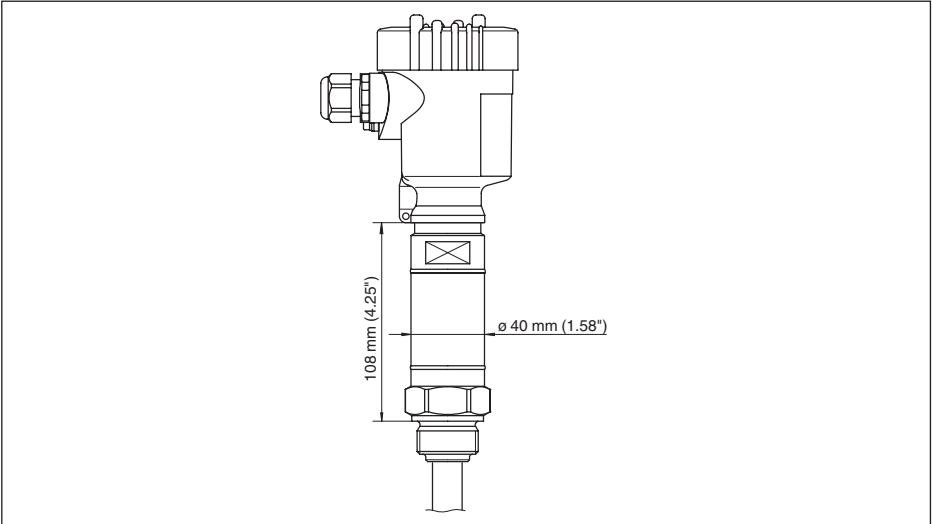

Fig. 33: Temperature adapter

9.3 Industrial property rights

VEGA product lines are global protected by industrial property rights. Further information see www.vega.com.

VEGA Produktfamilien sind weltweit geschützt durch gewerbliche Schutzrechte.

Nähere Informationen unter www.vega.com.

Les lignes de produits VEGA sont globalement protégées par des droits de propriété intellectuelle. Pour plus d'informations, on pourra se référer au site www.vega.com.

VEGA lineas de productos están protegidas por los derechos en el campo de la propiedad industrial. Para mayor información revise la pagina web www.vega.com.

Линии продукции фирмы ВЕГА защищаются по всему миру правами на интеллектуальную собственность. Дальнейшую информацию смотрите на сайте www.vega.com.

VEGA系列产品在全球享有知识产权保护。

进一步信息请参见网站www.vega.com。

9.4 Trademark

All the brands as well as trade and company names used are property of their lawful proprietor/originator.

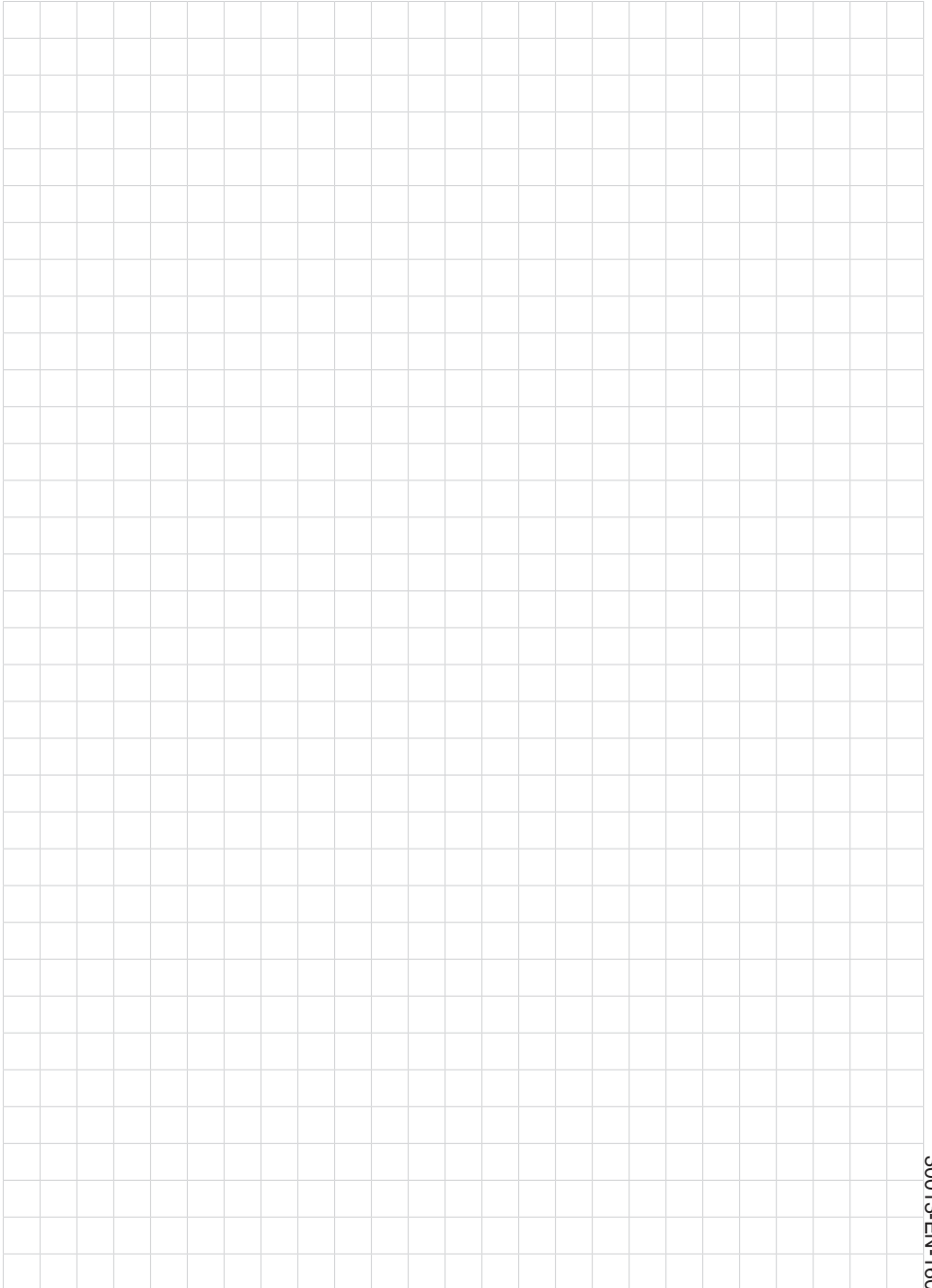



Printing date:

VEGA

All statements concerning scope of delivery, application, practical use and operating conditions of the sensors and processing systems correspond to the information available at the time of printing.

Subject to change without prior notice

© VEGA Grieshaber KG, Schiltach/Germany 2016



30013-EN-160331



THORNE &
DERRICK
INTERNATIONAL

Thorne & Derrick
+44 (0) 191 490 1547
www.heatingandprocess.com