

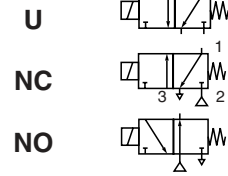

SOLENOID VALVES

direct operated
core disc
1/8 to 1/4



3/2
Series
314

FEATURES

- Three way solenoid valves direct operated with top exhaust
- Valves are designed to handle relatively high pressure 3-way applications
- Valves do not require a minimum operating pressure
- Valve operation is not affected by mounting position
- The use of first class materials and thorough valve testing ensure high reliability
- The solenoid valves satisfy all relevant EC Directives

GENERAL

Differential pressure 0 - 20 bar [1 bar = 100kPa]
Maximum viscosity 65cST (mm²/s)
Response times 5 - 25 ms

fluids (*)	temperature range (TS)	seal material (*)
air, inert gas, water, oil	-20 to + 90°C	NBR (nitrile)

MATERIALS IN CONTACT WITH FLUID

(*) Ensure that the compatibility of the fluids in contact with the materials is verified

	Brass body	Stainless steel body
Body	Brass	AISI 303 SS
Core tube	Stainless steel	Stainless steel
Core and plugnut	Stainless steel	Stainless steel
Springs	Stainless steel	Stainless steel
Seat	Brass & Stainless steel	Brass & Stainless steel
Sealings and discs	NBR	NBR
Riderring (1)	PTFE	PTFE
Cartridge (1)	Welded, packless AISI 430 SS	Welded, packless AISI 430 SS
Top disc	PA all executions	NBR
Core guide	CA	CA
Shading coil	Copper	Silver

(1) LP only

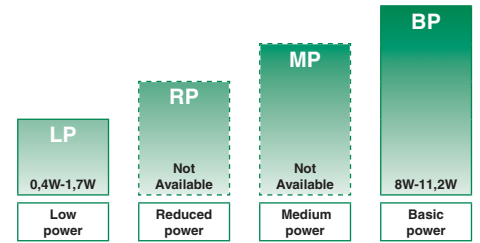
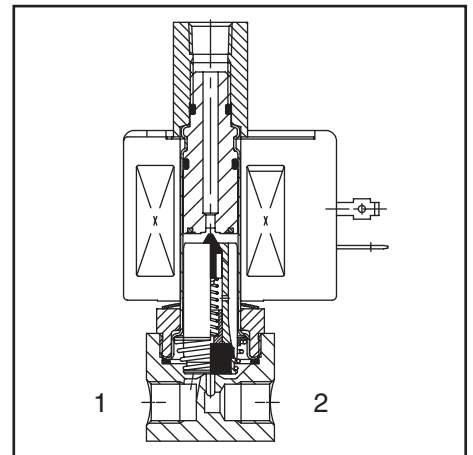

POWER LEVELS - cold electrical holding values (watt)

SPECIFICATIONS

pipe size	orifice size	flow coefficient Kv		operating pressure differential (bar)								power level	prefix optional solenoids				basic catalogue number		
				maximum (PS)									NEMA 7&9	ATEX / IECEx Ex e mb	IP65	PV			SC
				air/water/oil (*)															
NPT	(mm)	(m ³ /h)	(l/min)	min.	~	=	~	=	~	=	~/=	EF	EM	PV	SC	brass	stainless steel		
U - Universal																			
1/8	1,2	0,03	0,5	0	11	5	11	4	11	4	BP	●	●	●	●	B314C041	-		
1/4	1,2	0,03	0,5	0	11	5	11	4	11	4	BP	●	●	●	●	B314C006	-		
1/4	1,6	0,07	1,2	0	10	10	10	10	10	10	LP	○	●	○	●	B314A300	B314A301		
NC - Normally closed																			
1/8	1,2	0,03	0,5	0	16	8	16	10	16	9	BP	●	●	●	●	B314C031	-		
1/8	2,4	0,13	2,1	0	9	4	7	5	7	2	BP	●	●	●	●	B314C032	-		
1/4	1,2	0,03	0,5	0	16	8	16	10	16	9	BP	●	●	●	●	B314C034	-		
1/4	2,4	0,13	2,1	0	10	4	7	5	7	2	BP	●	●	●	●	B314C035	B314A121		
NO - Normally open																			
1/8	1,2	0,03	0,5	0	20	14	20	14	20	8	BP	●	●	●	●	B314C049	-		
1/8	2,4	0,13	2,1	0	12	5	12	6	12	3	BP	●	●	●	●	B314C050	-		
1/4	1,2	0,03	0,5	0	20	14	20	14	20	8	BP	●	●	●	●	B314C052	-		
1/4	2,4	0,13	2,1	0	12	5	12	6	12	3	BP	●	●	●	●	B314C053	B314A122		

● Available feature ○ Available feature in DC only - Not available



Thorne & Derrick
+44 (0) 191 490 1547
www.heatingandprocess.com

PREFIX TABLE

prefix							description	power level			
1	2	3	4	5	6	7		LP	RP	MP	BP
E	F						Explosionproof - NEMA 7, 9 - Zinc plated steel conduit	○	-	-	●
E	V						Explosionproof - NEMA 7, 9 - 316 SS conduit	○	-	-	●
E	M						Waterproof IP67 - Metal enclosure (EN/IEC 60079-7+18+31)*	●	-	-	●
		E	T				Threaded conduit/hole (M20 x 1,5)	●	-	-	●
P	V						Encapsulated epoxy moulded (EN/IEC 60079-18)*	○	-	-	●
S	C						Solenoid with spade plug connector (EN/IEC 60730)	●	-	-	●
W	P						Waterproof IP67 - Metal enclosure	●	-	-	●
W	S						Waterproof IP67 - 316 SS enclosure	●	-	-	●
W	S	E	M				Waterproof IP67 - 316 SS enclosure (EN/IEC 60079-7+18+31)*	●	-	-	●
				T			Threaded conduit (1/2" NPT)	●	-	-	●
					H	C	Class H - Battery charging circuit	-	-	-	●
					H	T	Class H - High temperature	-	-	-	●

SUFFIX TABLE

suffix					description	power level			
1	2	3	4	5		LP	RP	MP	BP
E					EPDM (ethylene-propylene)	-	-	-	●
J					CR (chloroprene)	-	-	-	●
N					Oxygen service (CR (chloroprene))	-	-	-	●
N	V				FPM (fluoroelastomer) and parts cleaned for oxygen service	-	-	-	●
T					PTFE (polytetrafluoroethylene)	-	-	-	●
V					FPM (fluoroelastomer)	-	-	-	●
W					UR (urethane)	-	-	-	●
	C	O			Epoxy coating on all external surfaces	●	-	-	●
	M	B			Mounting bracket	-	-	-	●

- Available feature
- Available feature in DC only
- Not available
- * ATEX/IECEx valves using these solenoids are approved according to EN 13463-1 (non electrical)

PRODUCT SELECTION GUIDE

STEP 1

Select basic catalogue number, including pipe thread identification letter. Refer to the specifications table on page 1.

Example: B314C006

STEP 2

Select prefix (combination). Refer to the specifications table on page 1 and the prefix table on page 2, respect the indicated power level.

Example: EM

STEP 3

Select suffix (combination) if required. Refer to the suffix table on page 2, respect the indicated power level.

Example: V

STEP 4

Select voltage. Refer to standard voltages on page 3.

Example: 230V / 50Hz

STEP 5

Final catalogue / ordering number.

Example:

EMB314C006 V 230V / 50Hz

OPTIONS & ACCESSORIES

catalogue number	spare parts kit no. ⁽¹⁾		mounting bracket no.
	~	=	
SC B 314C006	C302857	C302880	206525-001 ⁽²⁾
SC B 314C031	C302863	C302886	164706-001 ⁽²⁾
SC B 314C032	C302864	C302887	164706-001 ⁽²⁾
SC B 314C034	C302863	C302886	206525-001 ⁽²⁾
SC B 314C035	C302864	C302887	206525-001 ⁽²⁾
SC B 314C041	C302857	C302880	164706-001 ⁽²⁾
SC B 314C049	C302872	C302892	164706-001 ⁽²⁾
SC B 314C050	C302873	C302893	164706-001 ⁽²⁾
SC B 314C052	C302872	C302892	206525-001 ⁽²⁾
SC B 314C053	C302873	C302893	206525-001 ⁽²⁾
SC B 314A121	C314457	C314460	206525-001 ⁽²⁾
SC B 314A122	C314458	C314461	206525-001 ⁽²⁾
SC B 314A300	-	C316816	206525-001 ⁽²⁾
SC B 314A301	-	C316816	206525-001 ⁽²⁾

⁽¹⁾ Standard prefixes/suffixes are also applicable to kits

⁽²⁾ Mounting holes in body

ORDERING EXAMPLES:

WSEMT	B 314C006	230V / 50 Hz
SCHT	B 314C031 V	230V / 50 Hz
WP	B 314C032 MS	24V / DC
WS	B 314C049 V	24V / DC
SC	B 314C041	230V / 50 Hz
PV	B 314C035 CO	230V / 50 Hz
EF	B 314G053 MB	240V / 60 Hz

prefix⁽⁴⁾ pipe thread basic number⁽⁴⁾ voltage suffix

ORDERING EXAMPLES KITS:

WSEM	C302857
	C302864 V ⁽³⁾
	C302893 MO ⁽³⁾
WP	C302892 MS

prefix basic number suffix

⁽⁴⁾ Prefix EF and EV should always be used in conjunction with change letter G in the basic number

⁽³⁾ Basic kit number applies to SC coil construction

EXPLANATION OF TEMPERATURE RANGES OF SOLENOID VALVES

Valve temperature range The valve temperature range (TS) is determined by the selected seal material, the temperature range for proper operation of the valve and sometimes by the fluid (e.g. steam)

Operator ambient temperature range The operator ambient temperature range is determined by the selected power level and the safety code

Total temperature range The temperature range of the complete solenoid valve is determined by the limitations of both temperature ranges above

ELECTRICAL CHARACTERISTICS

Coil insulation class F

Electrical safety IEC 335

Standard voltages DC (=) 24V - 48V; Allowable voltage variation +10%, -15%

 AC (~) 24V - 48V - 115V - 230V/50/60Hz; Other voltages are available on request

prefix option	power ratings				operator ambient temperature range (C°) ⁽¹⁾	safety code	electrical enclosure protection (EN 60529)	replacement coil / kit		type ⁽²⁾
	inrush ~	holding ~	hot/cold =					~	=	
	(VA)	(VA)	(W)	(W)				230V/50 Hz	24V/DC	
Basic power (BP)										
SC	55,0	23,0	10,5	9,0/11,2	-40 to +75	EN 60730	IP65, moulded	400425-117	400425-142	01-02
WP/WS	55,0	23,0	10,5	9,0/11,2	-40 to +75	EN 60730	IP67, steel/SS	400405-117	400405-142	03-04
EM/WSEM	55,0	23,0	10,5	9,0/11,2	-40 to +40	II2G Ex e mb IIC Gb T3, II2D Ex tb IIIC Db	IP66/67, steel/SS	400909-117	400913-142	03-04
PV	55,0	23,0	10,5	9,0/11,2	-40 to +65	II2G/D Ex mb IIC Gb T3(-)/T4(=), IEx mb IIIC Db	IP67, moulded	- ⁽³⁾	- ⁽³⁾	05-06
EF	50,0	25,0	10,1	9,0/11,6	-40 to +52/40	NEMA type 7 and 9	NEMA 4X	238614-057D	238714-006D	07-08
Low Power (LP)										
SC	1,5	1,5	1,5	1,7/1,7	-40 to +60	EN 60730	IP65, moulded	400925-097	400925-042	09-10
WP/WS	1,5	1,5	1,5	1,7/1,7	-40 to +60	EN 60730	IP67, steel/SS	400926-097	400926-042	11-12
EM/WSEM	1,5	1,5	1,5	1,7/1,7	-40 to +40/55	II2G Ex e mb IIC Gb T6/T5, II2D Ex tb IIIC Db	IP66/67, steel/SS	400926-097	400926-042	11-12
PV	-	-	-	1,7/1,7	-40 to +60	II2G/D Ex mb IIC GbT6, Ex mb IIIC Db	IP67, moulded	-	- ⁽³⁾	13-14
EF	-	-	-	1,4/1,4	-40 to +60	NEMA type 7 and 9	NEMA 4X	-	238714-902D	15-16

⁽¹⁾ Temperature range can be limited by sealings

⁽²⁾ Refer to the dimensional drawings on page 4 and 5

⁽³⁾ Multiple coil kits are available under ATEX/IECEX, contact us

- Not available

ELECTRICAL CONNECTIONS

prefix	connection
SC	spade plug connector with cable gland EN175301-803A (ISO 4400) for cables with an outer diameter from 6 to 10 mm
WP, WS, EM, WSEM	M20 cable gland for cables with an outer diameter from 7 to 12 mm. With an internal and external facility for an earthing or bonding conductor

ADDITIONAL OPTIONS

- Other pipe threads are available on request
- Ex mb (prefix "PV") execution can be supplied in various cable lengths
- Compliance with "UL", "CSA" and other local approvals available on request
- 1/2" NPT (prefix "T") and M20 x 1,5 (prefix "ET") conduits (aluminium or 316 SS) available for steel solenoid housing
- Special moulded-in solid state components for peak voltage suppression and/or rectification (four diode bridge)

INSTALLATION

- Multi language installation/maintenance instructions are included with each valve
- The solenoid valves can be mounted in any position without affecting operation
- Threaded pipe connection identifier is B = NPT (ANSI 1.20.3)
- Declarations of conformity are available on request



DIMENSIONS (mm), WEIGHT (kg)



TYPE 01:
Epoxy moulded
SC: IEC 335 / ISO 4400

B314C006 / C031 / C032 / C034 / C035 / C041 /
B314C049 / C050 / C052 / C053

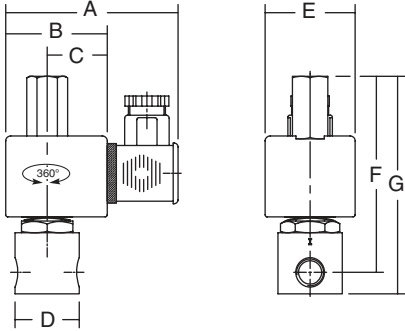

TYPE 02:
Epoxy moulded
SC: IEC 335 / ISO 4400

B314A121 / A122

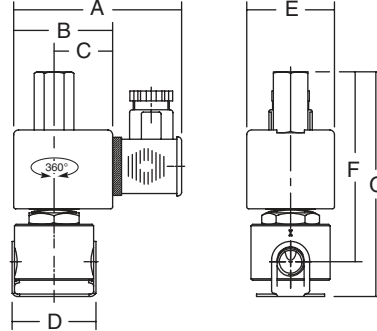

TYPE 03:
Metal, epoxy coated / AISI 316 SS
WP / WS: IEC 335
EM / WSEM: EN 60079-7, -18 and -31

B314C006 / C031 / C032 / C034 / C035 / C041 /
B314C049 / C050 / C052 / C053

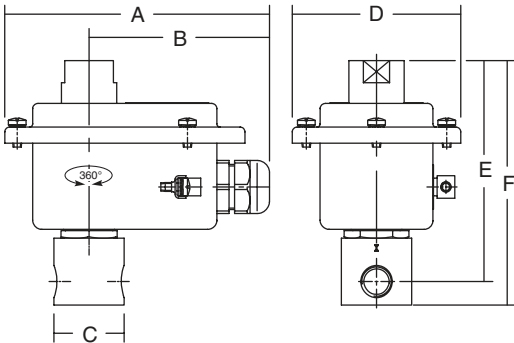

TYPE 04:
Metal, epoxy coated / AISI 316 SS
WP / WS: IEC 335
EM / WSEM: EN 60079-7, -18 and -31

B314A121 / A122

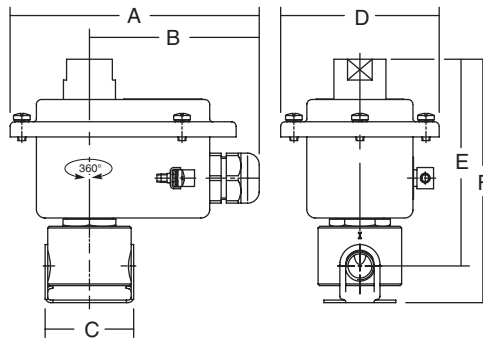

TYPE 05:
Epoxy encapsulated
PV: EN/IEC 60079-18

B314C006 / C031 / C032 / C034 / C035 / C041 /
B314C049 / C050 / C052 / C053

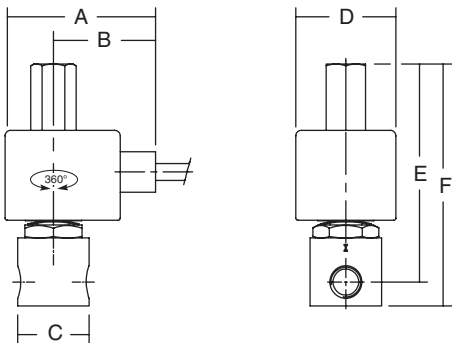

TYPE 06:
Epoxy encapsulated
PV: EN/IEC 60079-18

B314A121 / A122

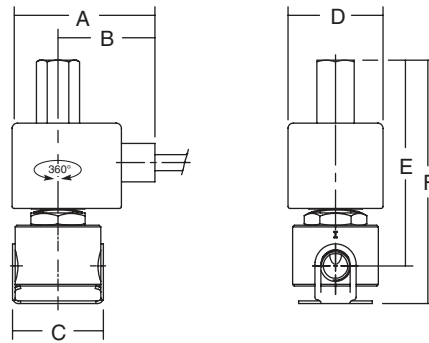

DIMENSIONS (mm), WEIGHT (kg)



TYPE 07:
Epoxy encapsulated
EF: ICS-6 ANSI / NEMA Type 7 and 9
NOTE: applicable to solenoid only

B314G006 / G031 / G032 / G034 / G035 / G041 / B314G049 / G050 / G052 / G053

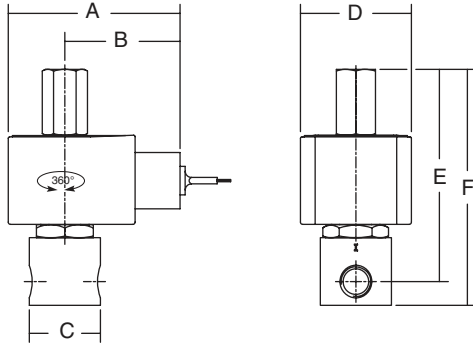

TYPE 08:
Epoxy encapsulated
EF: ICS-6 ANSI / NEMA Type 7 and 9
NOTE: applicable to solenoid only

B314G121 / G122

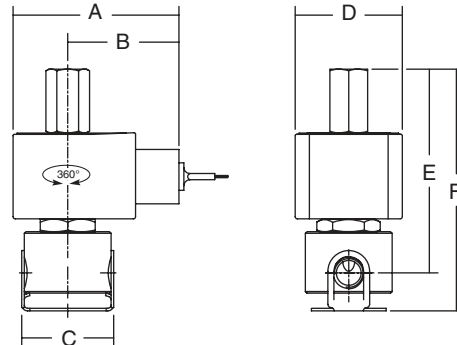

TYPE 09:
Epoxy moulded
SC: IEC 335 / ISO 4400

B314A300

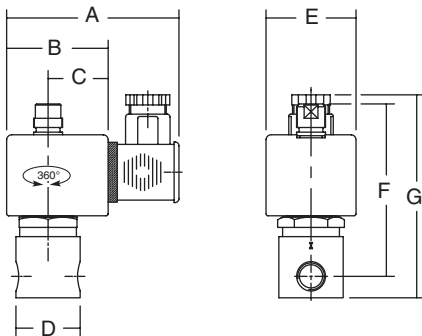

TYPE 10:
Epoxy moulded
SC: IEC 335 / ISO 4400

B314A301

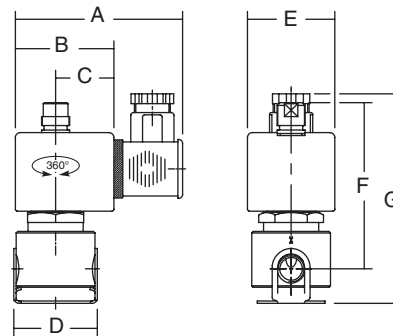

TYPE 11:
Metal, epoxy coated / AISI 316 SS
WP / WS: IEC 335
EM / WSEM: EN 60079-7, -18 and -31

B314A300

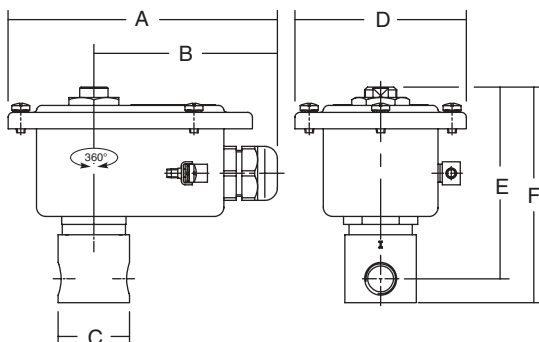

TYPE 12:
Metal, epoxy coated / AISI 316 SS
WP / WS: IEC 335
EM / WSEM: EN 60079-7, -18 and -31

B314A301

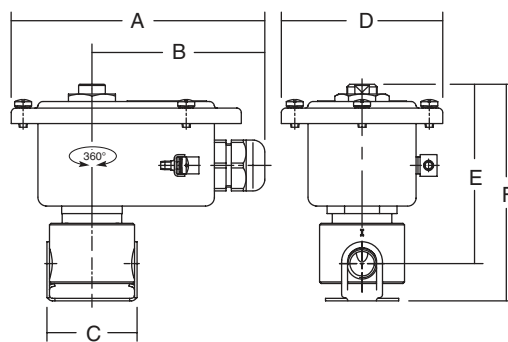

DIMENSIONS (mm), WEIGHT (kg) 



TYPE 13:
Epoxy encapsulated
PV: EN/IEC 60079-18



TYPE 14:
Epoxy encapsulated
PV: EN/IEC 60079-18

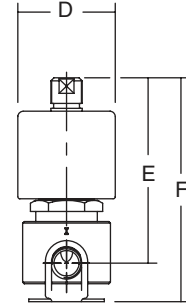
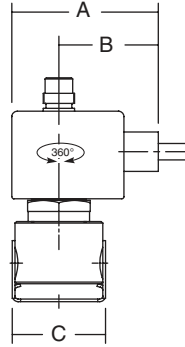
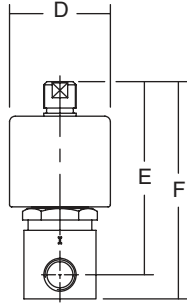
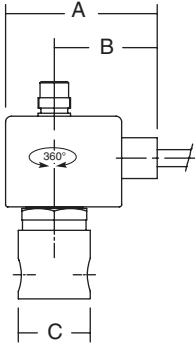

TYPE 15:
Epoxy encapsulated
EF: ICS-6 ANSI / NEMA Type 7 and 9
NOTE: applicable to solenoid only



TYPE 16:
Epoxy encapsulated
EF: ICS-6 ANSI / NEMA Type 7 and 9
NOTE: applicable to solenoid only

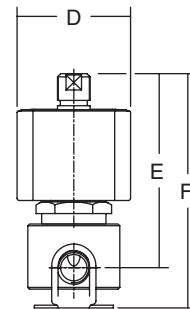
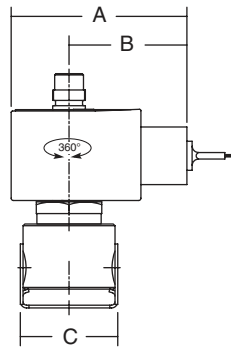
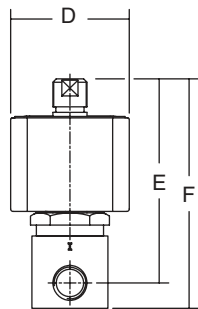
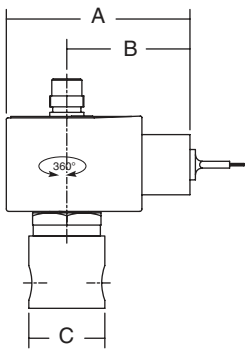

DIMENSIONS (mm), WEIGHT (kg)



type	prefix/option	power level	A	B	C	D	E	F	G	weight
01	SC	BP	80	50	30	32	45	90	99	0,45 kg
02	SC	BP	85	50	30	43	45	90	107	0,50 kg
03	WP, WS, EM/WSEM	BP	120	82	32	77	100	111	-	0,80 kg
04	WP, WS, EM/WSEM	BP	120	82	43	77	100	117	-	0,90 kg
05	PV	BP	67	45	32	45	97	108	-	0,45 kg
06	PV	BP	67	45	43	45	97	114	-	0,50 kg
07	EF	BP	77	51	32	50	95	105	-	0,45 kg
08	EF	BP	77	51	43	50	94	112	-	0,50 kg
09	SC	LP	80	50	30	32	45	85	100	0,75 kg
10	SC	LP	80	50	30	43	45	85	107	0,85 kg
11	WP, WS, EM/WSEM	LP	120	82	32	76	85	96	-	0,80 kg
12	WP, WS, EM/WSEM	LP	120	82	43	76	85	102	-	0,90 kg
13	PV	LP	67	45	32	45	85	96	-	0,80 kg
14	PV	LP	67	45	43	45	85	102	-	0,90 kg
15	EF	LP	77	51	32	50	85	96	-	0,80 kg
16	EF	LP	77	51	43	50	85	103	-	0,90 kg

SECTIONAL DRAWING

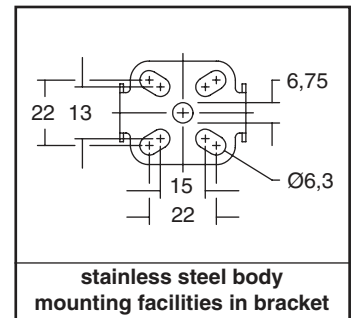
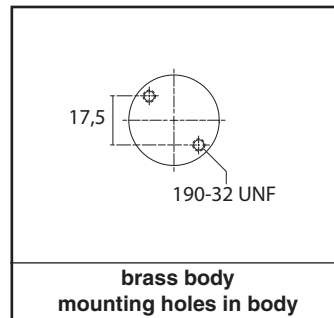
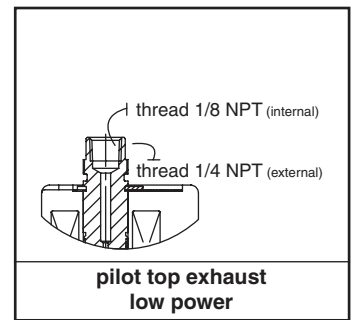
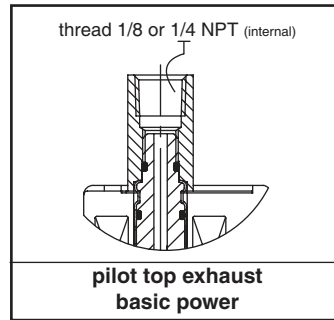
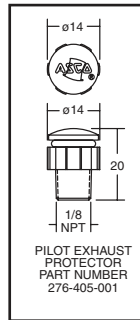
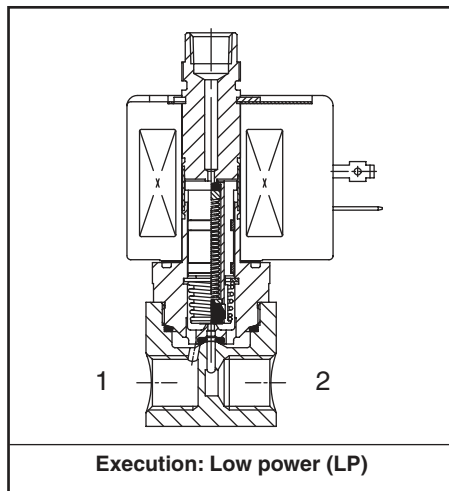

MOUNTING BRACKETS BRASS BODIED VALVES

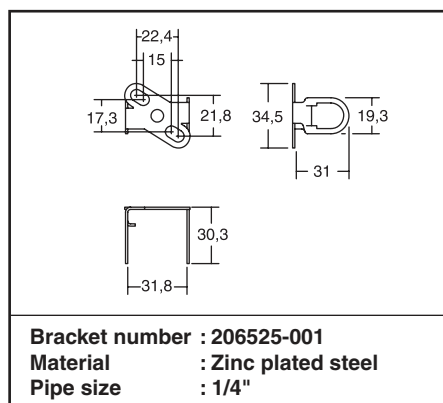
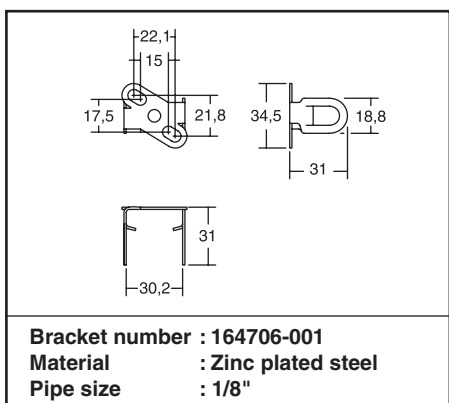



THORNE &
DERRICK
INTERNATIONAL

Thorne & Derrick
+44 (0) 191 490 1547
www.heatingandprocess.com