

FEATURES

The cylinders are designed for use in corrosive environments:

- chemical, salty or humid atmospheres
- food processing, dairy and meat industries: high resistance to lactic acid and bactericidal sprays

GENERAL

Detection	Equipped or not for magnetic position detectors
Fluid	Air or neutral gas, filtered, lubricated or not
Operating pressure	10 bar max.
Ambient temperature	-20°C to +80°C
Standards	ISO 15552

CONSTRUCTION

Barrel	Stainless steel 1.4301 AISI 304
Piston rod	Stainless steel 1.4571 AISI 316 TI
Tie rods	Ø 32 to 100 : Stainless steel 1.4571 AISI 316 TI Ø 125 : Stainless steel 1.4301 AISI 304
Front and rear covers	Stainless steel 1.4301 AISI 304
Piston rod nut	Stainless steel 1.4301 AISI 304
Seals	PUR (polyurethane) - NBR (nitrile)
Bearing	Sintered bronze
Cushioning	Adjustable pneumatic



B

SPECIFICATIONS

DEFINING THE CYLINDER CATALOGUE NUMBER

Standard version: tie rods with adjustable pneumatic cushioning, equipped for magnetic position detectors

To order, please specify:

- **CYLINDER** : - The cylinder type (single rod, through rod)
- The cylinder diameter and its stroke
- **DETECTORS** : The magnetic position detectors must be ordered separately :
- "T" IP69K model (see page P291), reed switch or magneto-resistive type

S / 000 00

cushioning	position detection	type	
		single rod	through rod
With	Not Equipped	E	F
With	Equipped	G	H

Ø (mm)	standard stroke (mm) ⁽²⁾ (recommended standard strokes)										
	25	50	80	100	125	160	200	250	320	400	500
32	•	•	•	•	•	•	•	•	•	•	•
40	•	•	•	•	•	•	•	•	•	•	•
50-63	•	•	•	•	•	•	•	•	•	•	•
80	•	•	•	•	•	•	•	•	•	•	•
100	•	•	•	•	•	•	•	•	•	•	•
125	•	•	•	•	•	•	•	•	•	•	•

(2) Other strokes on request.

cylinder Ø ⁽¹⁾	
type	Ø (mm)
032	32
040	40
050	50
063	63
080	80
100	100
125	125

(1) Ø 160 and 200mm on request.

Ordering example:

- Cylinder single rod with pneumatic cushioning equipped for detectors = **G**
 - Cylinder Ø 63 mm = **063**
 - Stroke 80 mm = **080**
- Ordering catalogue number: **SG063/008000000**

OPTIONS

- Grease for food processing, replace the 2 last digits by **N2**, example : SG063/008000**N2**

MOUNTINGS: see following pages

00607GB-2011/R01
Availability, design and specifications are subject to change without notice. All rights reserved.



**THORNE &
DERRICK
INTERNATIONAL**

Thorne & Derrick
+44 (0) 191 490 1547
www.heatingandprocess.com

Double Acting Cylinder with/without Magnetic Piston Single Rod End, Types SE or SG

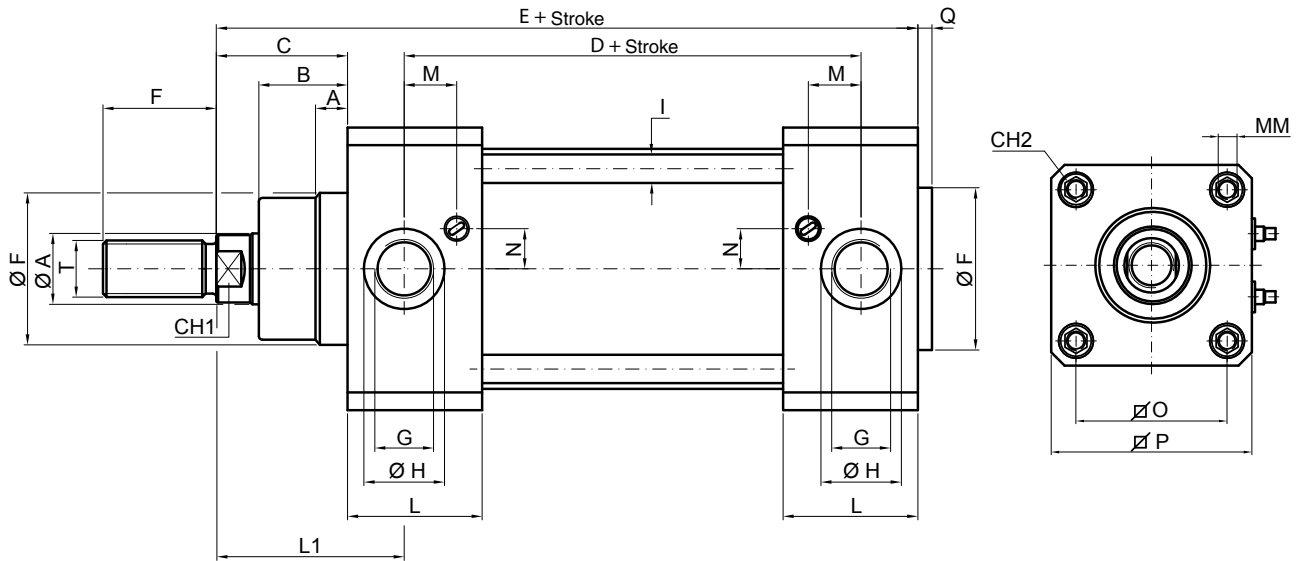

Thrust and retract forces (6 bar) single rod end

Piston diameter [mm]	Thrust force [N]	Retract force [N]
32	458	394
40	716	601
50	1180	939
63	1775	1596
80	2863	2583
100	4474	4194
125	6991	6532

Dimensions [mm]

Type	Piston diameter	Ø A	A	B	C	D	E	F	Ø F	G	L
SE; SG	32	12,0	9,0	18,0	26,0	67,0	121,0	22,0	30,0	G 1/8	30,8
SE; SG	40	16,0	9,0	22,0	30,0	77,0	135,0	24,0	35,0	G 1/4	33,0
SE; SG	50	20,0	9,0	25,5	37,0	78,0	143,0	32,0	40,0	G 1/4	33,7
SE; SG	63	20,0	9,0	25,0	37,0	89,0	158,0	32,0	45,0	G 3/8	38,0
SE; SG	80	25,0	9,0	35,0	46,0	96,0	174,0	40,0	45,0	G 3/8	40,0
SE; SG	100	25,0	9,0	38,0	51,0	102,0	189,0	40,0	55,0	G 1/2	43,5
SE; SG	125	32,0	11,0	46,0	65,0	124,0	225,0	54,0	60,0	G 1/2	53,2

Dimensions [mm]

Type	Piston diameter	L1	M	MM	N	O	P	Q	T	CH1	CH2
SE; SG	32	39.5	11.3	M6	6.0	32.5	50.0	4.0	M10x1.25	10	6
SE; SG	40	44.0	13.0	M6	8.0	38.0	55.0	4.0	M12x1.25	13	6
SE; SG	50	51.0	12.7	M8	11.8	46.5	65.0	4.0	M16x1.5	16	8
SE; SG	63	53.0	15.8	M8	11.7	56.5	75.0	4.0	M16x1.5	16	8
SE; SG	80	62.0	16.3	M10	15.5	72.0	95.0	4.0	M20x1.5	21	10
SE; SG	100	69.0	15.5	M10	15.5	89.0	110.0	4.0	M20x1.5	21	10
SE; SG	125	83.0	25.0	M12	19.0	110.0	139.0	6.0	M27x2.0	28	12

Double Acting Cylinder with/without Magnetic Piston Double Rod End, Types SF or SH

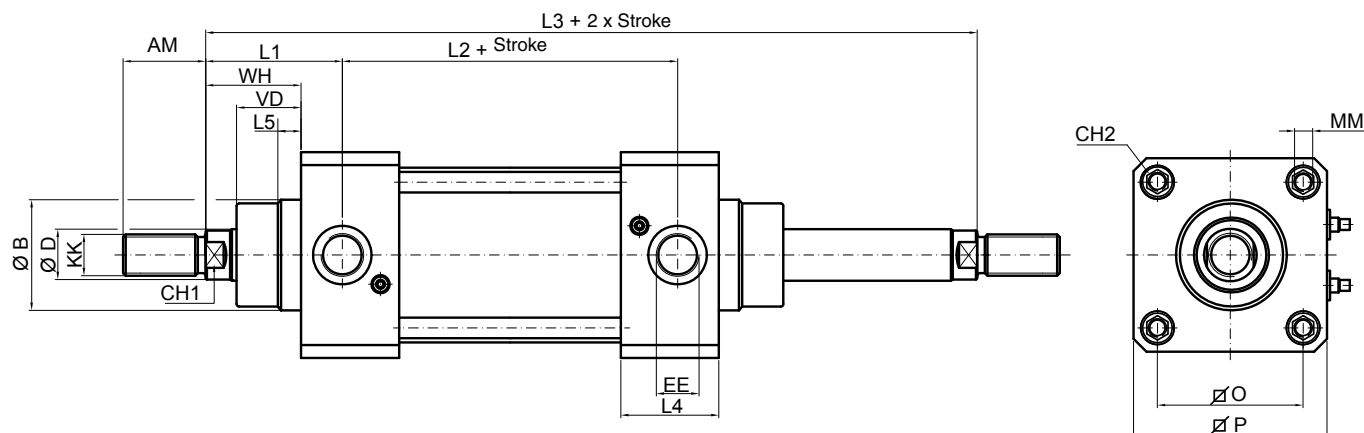

B

Retract and thrust forces (6 bar) double rod end

Piston diameter [mm]	Thrust / Retract force [N]
32	394
40	601
50	939
63	1596
80	2583
100	4194
125	6532



Dimensions [mm]

Type	Piston diameter	$\varnothing D$	$L5$	VD	WH	$L2$	$L3$	AM	$\varnothing B$	EE	$L4$
SF; SH	32	12.0	9.0	18.0	26.0	67.0	121.0	22.0	30.0	G 1/8	30.8
SF; SH	40	16.0	9.0	22.0	30.0	77.0	135.0	24.0	35.0	G 1/4	33.0
SF; SH	50	20.0	9.0	25.5	37.0	78.0	143.0	32.0	40.0	G 1/4	33.7
SF; SH	63	20.0	9.0	25.0	37.0	89.0	158.0	32.0	45.0	G 3/8	38.0
SF; SH	80	25.0	9.0	35.0	46.0	96.0	174.0	40.0	45.0	G 3/8	40.0
SF; SH	100	25.0	9.0	38.0	51.0	102.0	189.0	40.0	55.0	G 1/2	43.5
SF; SH	125	32.0	11.0	46.0	65.0	124.0	225.0	54.0	60.0	G 1/2	53.2

Dimensions [mm]

Type	Piston diameter	$L1$	M	MM	N	O	P	Q	T	$CH1$	$CH2$
SF; SH	32	39,5	11,3	M6	6,0	32,5	50,0	4,0	M10x1,25	10	6
SF; SH	40	44,0	13,0	M6	8,0	38,0	55,0	4,0	M12x1,25	13	6
SF; SH	50	51,0	12,7	M8	11,8	46,5	65,0	4,0	M16x1,5	16	8
SF; SH	63	53,0	15,8	M8	11,7	56,5	75,0	4,0	M16x1,5	16	8
SF; SH	80	62,0	16,3	M10	15,5	72,0	95,0	4,0	M20x1,5	21	10
SF; SH	100	69,0	15,5	M10	15,5	89,0	110,0	4,0	M20x1,5	21	10
SF; SH	125	83,0	25,0	M12	19,0	110,0	139,0	6,0	M27x2	28	12

00607GB-2011/R01
Availability, design and specifications are subject to change without notice. All rights reserved.

Foot Brackets (outside) to ISO 15552 for Cylinder with Piston Diameter 32 to 125 mm Stainless steel AISI 304

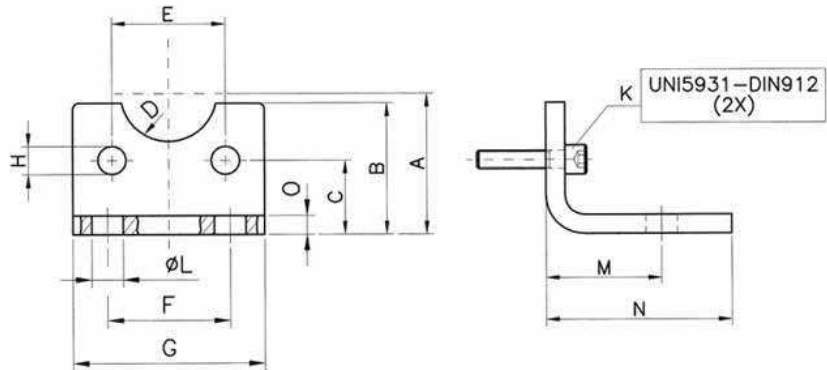

Dimensions [mm]

Piston diameter	A	B	C	D	E	F	G	H	K	L	M	N	O	Weight approx. [kg]	Order Code
32	32.0	30.0	15.75	R 15.0	32.5	32.0	45.0	7.0	M6x20	7.0	24.0	35.0	4.0	0.130	VC01/032-VA
40	36.0	30.0	17.0	R 17.5	38.0	36.0	52.0	7.0	M6x20	9.0	28.0	36.0	4.0	0.160	VC01/040-VA
50	45.0	36.0	21.75	R 2.00	46.5	45.0	65.0	9.0	M8x25	9.0	32.0	47.0	5.0	0.340	VC01/050-VA
63	50.0	35.0	21.75	R 22.5	56.5	50.0	75.0	9.0	M8x25	9.0	32.0	45.0	5.0	0.380	VC01/063-VA
80	63.0	47.0	27.0	R 22.5	72.0	63.0	95.0	11.0	M10x25	12.0	41.0	55.0	6.0	0.765	VC01/080-VA
100	71.0	53.0	26.5	R 27.5	89.0	75.0	115.0	11.0	M10x30	14.0	41.0	57.0	6.0	0.905	VC01/100-VA
125	90.0	70.0	35.0	R 30.0	110.0	90.0	140.0	14.0	M12x30	16.0	45.0	70.0	8.0	2.180	VC01/125-VA

Flange to ISO 15552 for Cylinder with Piston Diameter 32 to 125 mm Stainless steel AISI 304

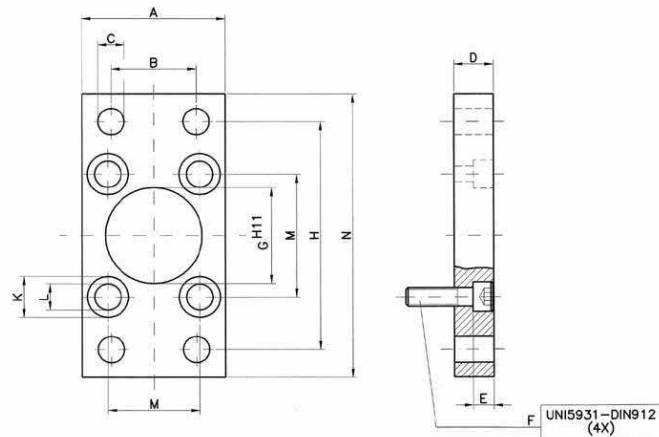

Dimensions [mm]

Piston diameter	A	B	C	D	E	F	G	H	K	L	M	N	Weight approx. [kg]	Order Code
32	45.0	32.0	7.0	10.0	6.5	M6x16	30.0	64.0	10.5	6.5	32.5	80.0	0.190	VC02/032-VA
40	52.0	36.0	9.0	10.0	6.5	M6x16	35.0	72.0	10.5	6.5	38.0	90.0	0.250	VC02/040-VA
50	65.0	45.0	9.0	12.0	8.5	M8x20	40.0	90.0	13.5	8.5	46.5	110.0	0.480	VC02/050-VA
63	75.0	50.0	9.0	12.0	8.5	M8x20	45.0	100.0	13.5	8.5	56.5	120.0	0.620	VC02/063-VA
80	95.0	63.0	12.0	16.0	10.5	M10x25	45.0	126.0	16.5	10.5	72.0	150.0	1.415	VC02/080-VA
100	115.0	75.0	14.0	16.0	10.5	M10x25	55.0	150.0	16.5	10.5	89.0	170.0	1.985	VC02/100-VA
125	140.0	90.0	16.0	20.0	9.5	M12x30	60.0	180.0	20.0	13.5	110.0	205.0	3.750	VC02/125-VA

Oscillating Brackets with Lugs to ISO 15552
for Cylinder with Piston Diameter 32 to 125 mm
Stainless steel AISI 304

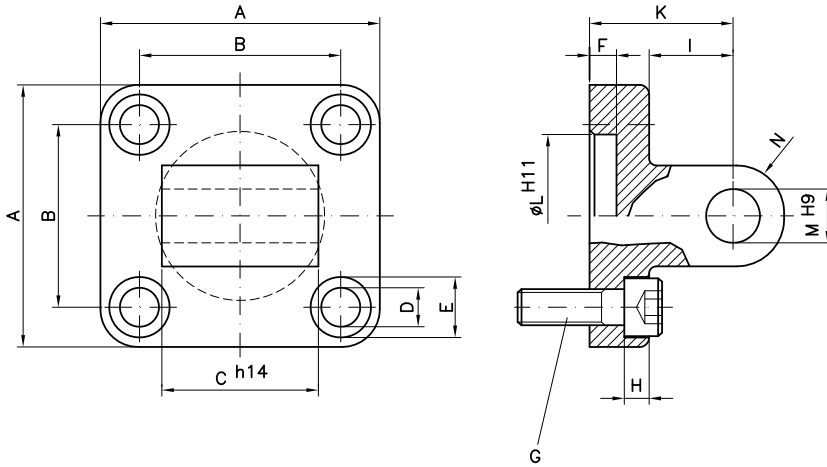

B

Dimensions [mm]

Piston diameter	A	B	C	D	E	F	G	H	I	K	L	M	N	Weight approx. [kg]	Order Code
32	45.0	32.5	26.0	6.6	11.0	5.0	M6x16	3.5	13.0	22.0	30.0	10.0	10.0	0.410	VC07/032-VA
40	52.0	38.0	28.0	6.6	11.0	5.0	M6x16	3.5	16.0	25.0	35.0	12.0	12.0	0.670	VC07/040-VA
50	65.0	46.5	32.0	9.0	15.0	5.0	M8x25	4.5	16.0	27.0	40.0	12.0	12.0	0.970	VC07/050-VA
63	75.0	56.5	40.0	9.0	15.0	5.0	M8x25	4.5	21.0	32.0	45.0	16.0	16.0	1.585	VC07/063-VA
80	95.0	72.0	50.0	11.0	18.0	5.0	M10x25	4.0	22.0	36.0	45.0	16.0	16.0	3.460	VC07/080-VA
100	115.0	89.0	60.0	11.0	18.0	5.0	M10x25	4.0	27.0	41.0	55.0	20.0	20.0	5.350	VC07/100-VA
125	140.0	110.0	70.0	14.0	20.0	7.0	M12x30	10.0	30.0	50.0	60.0	25.0	25.0	10.320	VC07/125-VA

Oscillating Brackets Fork Type to ISO 15552
for Cylinder with Piston Diameter 32 to 125 mm
Stainless steel AISI 304

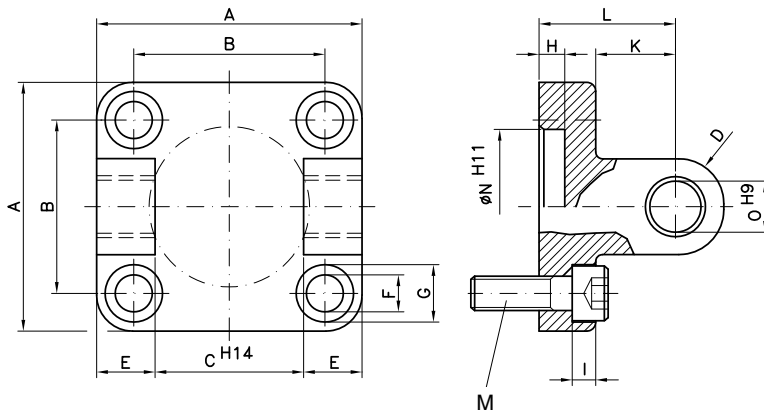

Dimensions [mm]

Piston diameter	A	B	C	D	E	F	G	H	I	K	L	M	N	O	Weight approx. [kg]	Order Code
32	45.0	32.5	26.0	10.0	9.5	6.6	11.0	5.0	3.5	13.0	22.0	M6x16	30.0	10.0	0.410	VC08/032-VA
40	52.0	38.0	28.0	12.0	12.0	6.6	11.0	5.0	3.5	16.0	25.0	M6x16	35.0	12.0	0.670	VC08/040-VA
50	65.0	46.5	32.0	12.0	14.0	9.0	15.0	5.0	4.5	16.0	27.0	M8x20	40.0	12.0	0.970	VC08/050-VA
63	75.0	56.5	40.0	16.0	15.0	9.0	15.0	5.0	4.5	21.0	32.0	M8x20	45.0	16.0	1.585	VC08/063-VA
80	95.0	72.0	50.0	16.0	20.0	11.0	18.0	5.0	4.0	22.0	36.0	M10x30	45.0	16.0	3.460	VC08/080-VA
100	115.0	89.0	60.0	20.0	25.0	11.0	18.0	5.0	4.0	27.0	41.0	M10x30	55.0	20.0	5.350	VC08/100-VA
125	140.0	110.0	70.0	25.0	30.0	14.0	20.0	7.0	10.0	30.0	50.0	M12x30	60.0	25.0	10.320	VC08/125-VA

00607GB-2011/R01
Availability, design and specifications are subject to change without notice. All rights reserved.

Right-angle Articulated Joint to ISO 15552
for Cylinder with Piston Diameter 32 to 125 mm
Stainless steel AISI 304

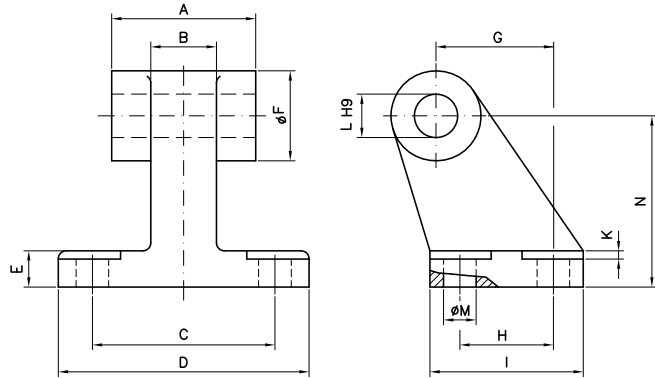

Dimensions [mm]

Piston diameter	A	B	C	D	E	ØF	G	H	I	K	L	ØM	N	Weight approx. [kg]	Order Code
32	26.0	10.0	38.0	51.0	8.0	20.0	21.0	18.0	31.0	1.6	10.0	6.6	32.0	0.160	VC11/032-VA
40	28.0	15.0	41.0	54.0	10.0	22.0	24.0	22.0	35.0	1.6	12.0	6.6	36.0	0.240	VC11/040-VA
50	32.0	16.0	50.0	65.0	12.0	26.0	33.0	30.0	45.0	1.6	12.0	9.0	45.0	0.420	VC11/050-VA
63	40.0	16.0	52.0	67.0	14.0	30.0	37.0	35.0	50.0	1.6	16.0	9.0	50.0	0.525	VC11/063-VA
80	50.0	20.0	66.0	86.0	14.0	30.0	47.0	40.0	60.0	2.5	16.0	11.0	63.0	1.055	VC11/080-VA
100	60.0	20.0	76.0	96.0	17.0	38.0	55.0	50.0	70.0	2.5	20.0	11.0	71.0	1.360	VC11/100-VA
125	70.0	30.0	94.0	124.0	20.0	45.0	70.0	60.0	90.0	3.2	25.0	14.0	90.0	2.500	VC11/125-VA

Rod Clevis
for Cylinder with Piston Diameter 32 to 125 mm
Stainless steel AISI 303

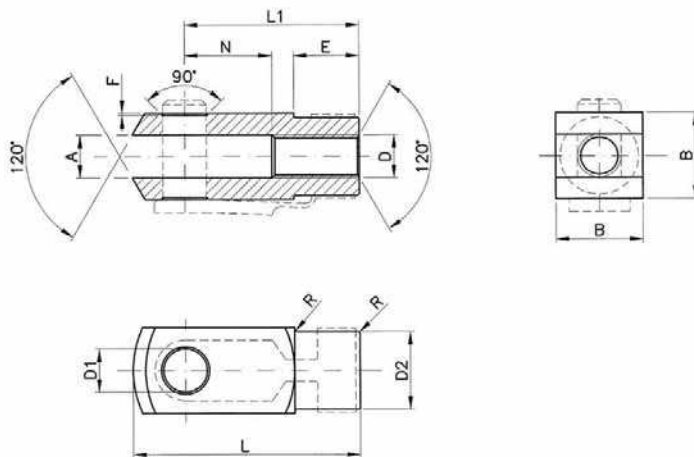

Dimensions [mm]

Piston diameter	A	B	D	D1	D2	E	F	L	L1	N	R	Weight approx. [kg]	Order Code
32	10.0	20.0	M10x1.25	10.0	18.0	15.0	0.5	52.0	40.0	20.0	0.5	0.090	SC4/025-VA
40	12.0	24.0	M12x1.25	12.0	20.0	18.0	0.5	62.0	48.0	24.0	0.5	0.150	SC4/040-VA
50 / 63	16.0	32.0	M16x1.5	16.0	26.0	24.0	1.0	83.0	64.0	32.0	1.0	0.340	SC4/050-VA
80 / 100	20.0	40.0	M20x1.5	20.0	34.0	30.0	1.0	105.0	80.0	40.0	1.0	0.690	SC4/080-VA
125	30.0	55.0	M27x2	30.0	48.0	38.0	1.0	148.0	110.0	54.0	1.0	1.820	SC4/125-VA

Oscillating Clevis

for Cylinders with Piston Diameters 32 to 125 mm
Stainless steel AISI 304

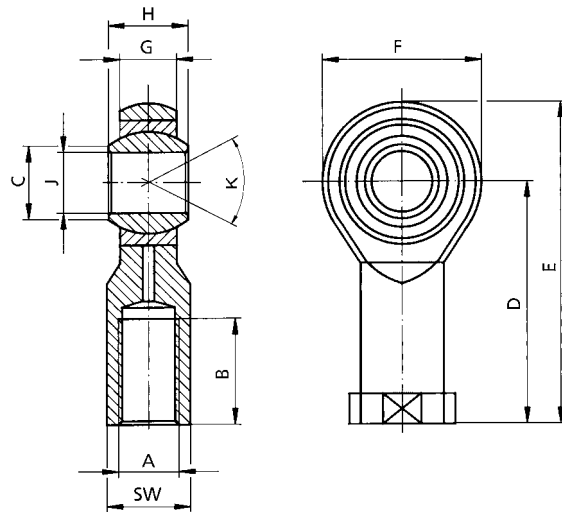

B

Dimensions [mm]

Piston diameter	A	B	C ø	D	E	F	G	H	J ø H7	K	SW	Weight approx. [kg]	Order Code
32	M10x1.25	20.0	13.0	43.0	57.0	28.0	10.5	14.0	10.0	8°	17	0.075	SC5/025-VA
40	M12x1.25	22.0	15.5	50.0	66.0	32.0	12.0	16.0	12.0	8°	19	0.115	SC5/040-VA
50 / 63	M16x1.5	28.0	19.5	64.0	85.0	42.0	15.0	21.0	16.0	8°	22	0.230	SC5/050-VA
80 / 100	M20x1.5	33.0	24.5	77.0	102.0	50.0	18.0	25.0	20.0	8°	30	0.415	SC5/080-VA
125	M27x2	51.0	34.5	110.0	145.0	70.0	25.0	37.0	30.0	6°	41	1.130	SC5/125-VA

Pivot Variable

for Cylinder with Piston Diameter 32 to 125 mm
Stainless steel AISI 304

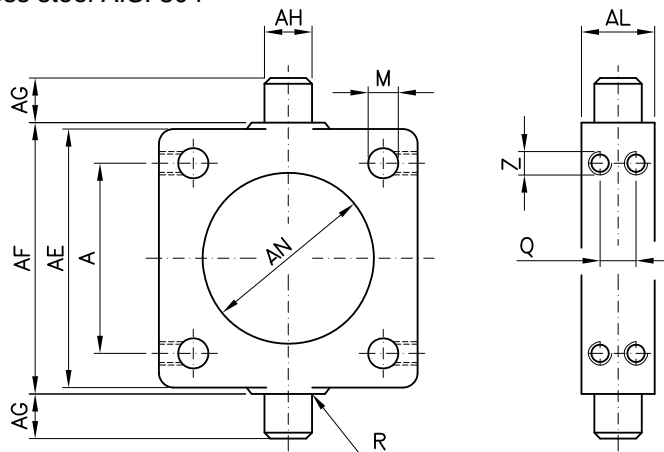

Dimensions [mm]

Piston diameter	A	AE	AL	AH	AG	AF	AN	R	M	Q	Z	Weight approx. [kg]	Order Code
32	32.5	46.0	15.0	12.0	12.0	50.0	37.0	1.0	6.25	7.0	M5	0.130	ZCV9/032-VA
40	38.0	59.0	20.0	16.0	16.0	63.0	46.0	1.5	6.25	8.0	M5	0.310	ZCV9/040-VA
50	46.5	69.0	20.0	16.0	16.0	75.0	56.0	1.6	8.25	8.0	M6	0.370	ZCV9/050-VA
63	56.5	84.0	25.0	20.0	20.0	90.0	69.0	1.6	8.25	12.0	M6	0.690	ZCV9/063-VA
80	72.0	102.0	25.0	20.0	20.0	110.0	87.0	1.6	10.25	12.0	M8	0.895	ZCV9/080-VA
100	89.0	125.0	30.0	25.0	25.0	132.0	107.0	2.0	12.25	15.0	M8	1.585	ZCV9/100-VA
125	110.0	155.0	32.0	25.0	25.0	160.0	133.0	2.0	12.25	15.0	M10	2.600	ZCV9/125-VA

Force Table for Double Acting Cylinders
with Piston Diameters 32 to 200 mm

Piston Diameter [mm]	Piston Rod Diameter [mm]	Effective Piston Surface [cm²]	Pressure [bar]									
			2	3	4	5	6	7	8	9	10	
32	12	for thrust	8.0	141	212	282	353	424	494	565	636	706
		for tension	6.9	122	182	243	304	366	427	488	549	610
40	16	for thrust	12.6	223	334	445	555	667	780	893	1.001	1.109
		for tension	10.6	187	281	375	468	561	655	748	843	936
50	20	for thrust	19.6	346	520	692	865	1.040	1.207	1.383	1.560	1.727
		for tension	17.6	310	464	618	772	926	1.080	1.234	1.388	1.542
63	20	for thrust	31.2	551	827	1.099	1.373	1.648	1.933	2.207	2.482	2.757
		for tension	28.1	495	746	991	1.236	1.491	1.736	1.982	2.237	2.482
80	25	for thrust	50.3	889	1.334	1.776	2.217	2.668	3.110	3.551	4.002	4.444
		for tension	45.3	800	1.197	1.599	2.001	2.403	2.806	3.198	3.600	4.002
100	25	for thrust	78.5	1.383	2.080	2.776	3.463	4.159	4.856	5.543	6.239	6.926
		for tension	73.6	1.295	1.952	2.600	3.247	3.895	4.552	5.199	5.847	6.494
125	32	for thrust	122.7	2.168	3.247	4.336	5.415	6.497	7.583	8.662	9.751	10.830
		for tension	115.7	2.036	3.054	4.072	5.090	6.108	7.126	8.144	9.162	10.180
160	40	for thrust	201.1	3.551	5.327	7.102	8.878	10.654	12.429	14.205	15.980	17.756
		for tension	188.5	3.326	4.993	6.651	8.319	9.987	11.644	13.312	14.970	16.638
200	40	for thrust	314.2	5.563	8.319	11.095	13.871	16.648	19.424	22.190	24.966	27.743
		for tension	301.6	5.327	7.985	10.654	13.312	15.971	18.639	21.297	23.966	26.624

Friction losses are considered with 10%.

Table on Air Consumption for Double Acting Cylinders
with Piston Diameters 32 to 200 mm

Piston Diameter [mm]	Pressure [bar]									
	2	3	4	5	6	7	8	9	10	
	Air Consumption [l] per 100 mm Stroke (uncompressed air)									
32	0.3	0.4	0.6	0.7	0.9	0.9	1.2	1.3	1.5	
40	0.5	0.7	0.9	1.2	1.4	1.6	1.8	2.1	2.3	
50	0.7	1.1	1.4	1.8	2.2	2.5	2.9	3.3	3.6	
63	1.2	1.8	2.4	3.0	3.6	4.1	4.7	5.3	5.9	
80	1.9	2.9	3.8	4.8	5.7	6.7	7.6	8.6	9.6	
100	3.0	4.6	6.1	7.6	9.1	10.7	12.2	13.7	15.2	
125	4.7	7.1	9.5	11.9	14.2	16.6	19.0	21.4	23.7	
160	7.8	11.7	15.6	19.5	23.4	27.3	31.2	35.1	39.0	
200	12.3	18.5	24.6	30.8	37.0	43.1	49.3	55.4	61.6	

Value for 1 double stroke

Break-away Pressures for Double Acting Cylinders
with Piston Diameters 32 to 100 mm

Piston Diameter [mm]	Type WG [bar]	Type ZG [bar]
32	0.15-0.30 (0.70)	0.15-0.30 (0.80)
40	0.10-0.20 (0.60)	0.15-0.30 (0.70)
50	0.10-0.20 (0.60)	0.15-0.30 (0.60)
63	0.10-0.20 (0.40)	0.10-0.25 (0.50)
80	0.10-0.20 (0.40)	0.10-0.25 (0.50)
100	0.10-0.20 (0.40)	0.10-0.25 (0.50)

On request: break-away pressures Ø 125 mm to Ø 320 mm

The values in brackets refer to a cylinder which has remained in its final position for a longer period of time (several hours or days). Due to long rest periods the material elastomer can "flow" into the rough walls of the cylinder barrel and it can "interlock". For cylinders that are regularly in motion the first values without brackets are valid, as the "sticking effect" occurs only after a longer rest period.

