



## VFS-FP

### (ATEX/IECEX Vertical Float Switch)

The Deeter VFS-FP is a vertical magnetic float switch for control and indication of a liquid level while in a potentially explosive atmosphere.



VFS-FP

Ex d IIC T5 Ga/Gb

Ex t IIIIC T100°C Db IP68

-20°C<Ta<+85°C

Atex Certificate: Sira 11ATEX1365

IECEX Certificate: IECEX SIR 11.0159

Refer to certificate for clarification of directive code and equipment protection level.



#### Features include

- ATEX and IECEX approved.
- Stainless Steel 316L housing and wetted components.
- Suitable for gas and dust environments.
- IP68 Ingress protection.
- Voltage free reed switch contacts
- Narrow sensor stem and external mounting.
- Suitable for high liquid temperatures.



THORNE &  
**DERRICK**  
INTERNATIONAL

Thorne & Derrick  
+44 (0) 191 490 1547  
[www.heatingandprocess.com](http://www.heatingandprocess.com)



## VFS-FP (ATEX/IECEx Vertical Float Switch)

Type	Specification	
Sensor technology	Magnetic float with reed switch	
Sensor tube and wetted materials	Stainless steel 316L	
Connection head material	Stainless steel 316L	
IP rating with suitable cable gland	IP68	
Approximate weight:	1.383 kg	
Float Diameter: Specific gravity:	52.6mm : 0.6	
Maximum liquid temperature:	-20 to +85°C	125°C/190° C on request
Maximum head temperature	-20 to +80°C	Note 1
Maximum operating pressure	150PSI / 10Bar standard	Note 2
Thread connection-Sensor tube	½" NPT	
Thread connection-Tank Mounting	2" BSP	
Thread connection-Wiring port	M20X1.5	
Connection head height	95mm	
Power supply:	Voltage free contacts	
Switch rating:	0 to 240vac. 1Amp. 50Watts max	Note 3

Note 1: When this equipment is intended to be used in a liquid with a process temperature above 85°C it is an essential requirement that the sensor head temperature is measured to determine if the ambient air cooling is sufficient to keep the head below 80°C. See installation manual for detail.

Note 2: The F/S FP sensor float and tube can withstand the stated pressure when sealed inside a tank. The connection head and resin seal to the sensor stem must not be pressurised. The standard zone0 fittings are rated at 10bar, these fittings are not part of the certified flameproof seal and should not be considered as part of an explosion proof containment. Please call our technical sales department regarding sensors for liquid pressures up to 31bar.

Note 3: The sum current drawn by all switch points must not exceed 1Amp total.

Note 4: Sensors suitable for higher temperatures are available.

Deeter House  
Valley Road  
Hughenden Valley  
Bucks HP14 4LW

Tel: +44 (0)1494 566 046  
Fax: +44 (0)1494 563 961  
Email: sales@deeter.co.uk



www.deeter.co.uk

## VFS-FP (ATEX/IECEx Vertical Float Switch)

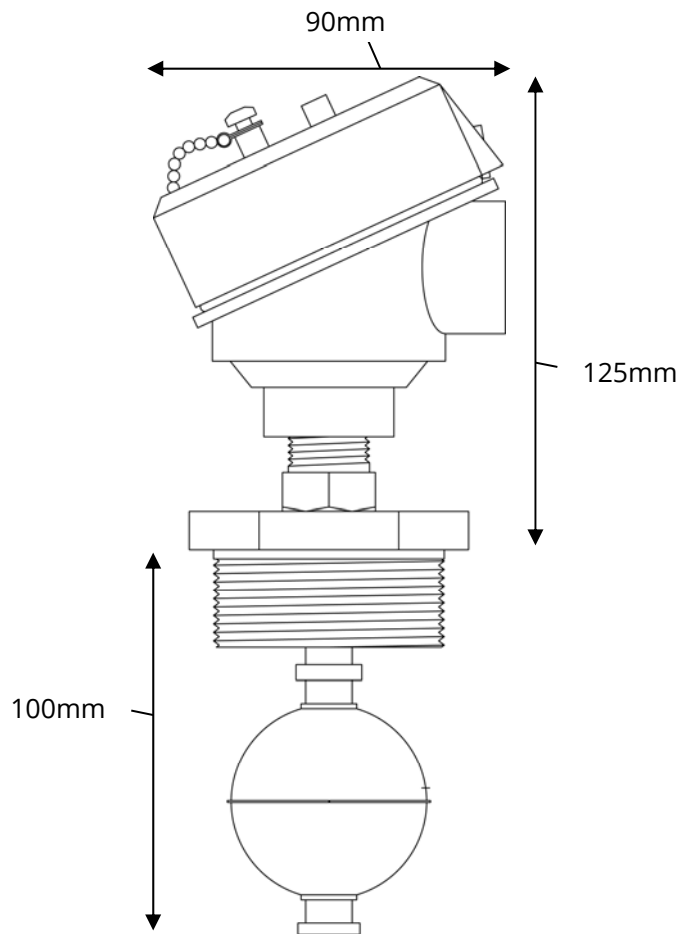

### Ordering Code

VFS	-	FP
-----	---	----

VFS-FP = VFS-FP ATEX/IECEx Vertical Liquid Level Sensor

Custom options available please call our sales office to discuss your requirements. Options include: Probe length, Switch voltage, Switch point quantity, Switch point height, Threaded mounting/seal options, Reed/Hall Effect technology, float sizes, 8 or 12mm sensor tube, cable entry thread.

**All electrical equipment should be installed by a qualified/certified electrician.**

The Deeter Group follows a policy of continual development of its products and reserves the right to change specifications and/or features without notice.