



Product information

Controllers and communication

Controllers in field housing for continuously measuring level sensors

VEGAMET 141, 142
VEGAMET 341, 342
VEGAMET 841, 842
VEGAMET 861, 862



Document ID: 62826



THORNE &
DERRICK
INTERNATIONAL

Thorne & Derrick
+44 (0) 191 410 4292
www.heatingandprocess.com

VEGA

Contents

1	Product description	3
2	Type overview.....	4
3	Instrument selection.....	7
4	Selection criteria.....	8
5	Mounting.....	13
6	Electrical connection.....	15
7	Adjustment	18
8	Dimensions.....	19

Take note of safety instructions for Ex applications



Please note the Ex specific safety information which you can find on our homepage www.vega.com/downloads under "Approvals" and which comes with every instrument. In hazardous areas you should take note of the corresponding regulations, conformity and type approval certificates of the sensors and power supply units. The sensors must only be operated on intrinsically safe circuits. The permissible electrical values are stated in the certificate.

1 Product description

Functional principle

In continuous measurement, for example, the level in a vessel is detected by a sensor and then transferred to a controller for further processing. By means of an adjustment in the controller, the measured value can be adapted to the individual circumstances. The requested measurement parameter is indicated in the display via a scaling/linearisation. The measured value can be transmitted additionally to a connected control system or visualisation via the current output.

Several operating relays are additionally integrated in each VEGAMET for level detection. These can be used to control pumps or other actuators.

Application

The controllers can be used in connection with the appropriate sensors for a large number of measuring tasks. Preset applications and functions are already integrated for convenient set-up which can be selected and adapted very easily by means of an application wizard.

The following applications and functions are available, for example, depending on the instrument type:

- Universal
- Level storage tank
- Calculation difference
- Calculation total
- Calculation of average value
- Wells
- Pumping station
- Sewage screw lifting station
- Density
- Overflow basin
- Screen control
- Flow measurement flume/weir
- Pressurized vessel
- Measured value memory/data logger

All instruments also serve as a (Ex) power supply unit for the connected sensors. Power is supplied via the same two-wire cable. As an option in the non-Ex versions, an input without sensor power supply (passive input) is available, enabling the connection of transmitters with their own voltage supply (sensors in four-wire version). Depending on the instrument type, one or two independent sensors can be connected and their measured values processed.

Safety

The integrated function monitoring detects faults in the controller as well as in the connected sensors. If such a fault is detected, the integrated fail safe relay de-energises (safe status) and a fault signal is output via the LEDs on the front panel. In addition, the current output of each VEGAMET jumps to an adjustable fault current.

The instrument has the following approvals:

- Ex approval as auxiliary, intrinsically safe instrument
- Ship approval for the VEGAMET series 100/300
- Certificate as WHG-conform limit signal transmitter

Adjustment

All devices can be operated on site via the integrated display and adjustment unit. Wireless operation via Bluetooth using the following adjustment tools is also possible:

- Smartphone/tablet (iOS or Android operating system)
- PC/notebook with Bluetooth LE or Bluetooth USB adapter (Windows operating system)

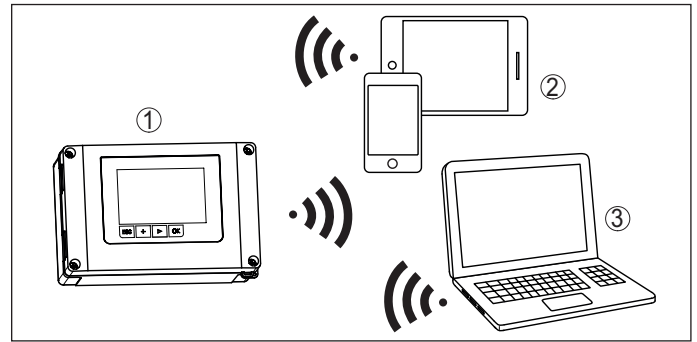

Fig. 1: Wireless connection to smartphone/table/notebook

- 1 VEGAMET
- 2 Smartphone/Tablet
- 3 PC/Notebook

2 Type overview

VEGAMET 141



VEGAMET 142



Mounting	Carrier rail mounting	Carrier rail mounting
Application	<ul style="list-style-type: none"> ● Level/gauge measurement ● Wells ● Pumping station ● Sewage screw lifting station ● Process pressure measurement ● Flow measurement 	<ul style="list-style-type: none"> ● Level/gauge measurement ● Wells ● Pumping station ● Sewage screw lifting station ● Flow measurement ● Density ● Overflow basin ● Screen control ● Pressurized vessel ● Calculation difference/sum/average
Measurement loops	1 Measurement loop	2 measuring loops, 1 arithmetic measuring loop
Sensor inputs	1 x 4 ... 20 mA	2 x 4 ... 20 mA
Digital inputs	-	-
Outputs	<ul style="list-style-type: none"> ● 3 x operating relay, one can be configured as fail safe relay ● 1 x current output 	<ul style="list-style-type: none"> ● 3 x operating relay, one can be configured as fail safe relay ● 2 x current outputs
Display on the instrument	<ul style="list-style-type: none"> ● Graphic-capable LC display, with lighting ● LEDs for operation, relays, fault signal ● Configurable status indication via display background lighting 	<ul style="list-style-type: none"> ● Graphic-capable LC display, with lighting ● LEDs for operation, relays, fault signal ● Configurable status indication via display background lighting
Measured value memory	-	-
Interfaces	Bluetooth LE	Bluetooth LE
Ambient temperature	-40 ... +60 °C (-40 ... +140 °F)	-40 ... +60 °C (-40 ... +140 °F)

VEGAMET 341



VEGAMET 342



Mounting	Panel mounting	Panel mounting
Application	<ul style="list-style-type: none"> ● Level/gauge measurement ● Wells ● Pumping station ● Sewage screw lifting station ● Process pressure measurement ● Flow measurement 	<ul style="list-style-type: none"> ● Level/gauge measurement ● Wells ● Pumping station ● Sewage screw lifting station ● Flow measurement ● Density ● Overflow basin ● Screen control ● Pressurized vessel ● Calculation difference/sum/average
Measurement loops	1 Measurement loop	2 measuring loops, 1 arithmetic measuring loop
Sensor inputs	1 x 4 ... 20 mA	2 x 4 ... 20 mA
Digital inputs	-	-
Outputs	<ul style="list-style-type: none"> ● 3 x operating relay, one can be configured as fail safe relay ● 1 x current output 	<ul style="list-style-type: none"> ● 3 x operating relay, one can be configured as fail safe relay ● 2 x current outputs
Display on the instrument	<ul style="list-style-type: none"> ● Graphic-capable LC display, with lighting ● LEDs for operation, relays, fault signal ● Configurable status indication via display background lighting 	<ul style="list-style-type: none"> ● Graphic-capable LC display, with lighting ● LEDs for operation, relays, fault signal ● Configurable status indication via display background lighting
Measured value memory	-	-
Interfaces	Bluetooth LE	Bluetooth LE
Ambient temperature	-40 ... +60 °C (-40 ... +140 °F)	-40 ... +60 °C (-40 ... +140 °F)

VEGAMET 841



VEGAMET 842



Mounting	Wall/pipe assembly	Wall/pipe assembly
Application	<ul style="list-style-type: none"> ● Level/gauge measurement ● Wells ● Pumping station ● Sewage screw lifting station ● Process pressure measurement ● Flow measurement 	<ul style="list-style-type: none"> ● Level/gauge measurement ● Wells ● Pumping station ● Sewage screw lifting station ● Flow measurement ● Density ● Overflow basin ● Screen control ● Pressurized vessel ● Calculation difference/sum/average
Measurement loops	1 Measurement loop	2 measuring loops, 1 arithmetic measuring loop
Sensor inputs	1 x 4 ... 20 mA	2 x 4 ... 20 mA
Digital inputs	-	-
Outputs	<ul style="list-style-type: none"> ● 3 x operating relay, one can be configured as fail safe relay ● 1 x current output 	<ul style="list-style-type: none"> ● 3 x operating relay, one can be configured as fail safe relay ● 2 x current outputs
Display on the instrument	<ul style="list-style-type: none"> ● Graphic-capable LC display, with lighting ● LEDs for operation, relays, fault signal ● Configurable status indication via display background lighting 	<ul style="list-style-type: none"> ● Graphic-capable LC display, with lighting ● LEDs for operation, relays, fault signal ● Configurable status indication via display background lighting
Measured value memory	-	-
Interfaces	Bluetooth LE	Bluetooth LE
Ambient temperature	-40 ... +60 °C (-40 ... +140 °F)	-40 ... +60 °C (-40 ... +140 °F)

VEGAMET 861



VEGAMET 862



Mounting	Wall/pipe assembly	Wall/pipe assembly
Application	<ul style="list-style-type: none"> ● Level/gauge measurement ● Wells ● Pumping station ● Sewage screw lifting station ● Process pressure measurement ● Flow measurement 	<ul style="list-style-type: none"> ● Level/gauge measurement ● Wells ● Pumping station ● Sewage screw lifting station ● Flow measurement ● Density ● Overflow basin ● Screen control ● Pressurized vessel ● Calculation difference/sum/average
Measurement loops	1 Measurement loop	2 measuring points, 1 differential measuring point
Sensor inputs	1 x 4 ... 20 mA/HART	2 x 4 ... 20 mA/HART
Digital inputs	2 Digital inputs	4 Digital inputs
Outputs	<ul style="list-style-type: none"> ● 4 x operating relay, one can be configured as fail safe relay ● 1 x current output 	<ul style="list-style-type: none"> ● 6 x operating relay, one can be configured as fail safe relay ● 3 x current output
Display on the instrument	<ul style="list-style-type: none"> ● Graphic-capable LC display, with lighting ● LEDs for operation, relays, fault signal ● Configurable status indication via display background lighting 	<ul style="list-style-type: none"> ● Graphic-capable LC display, with lighting ● LEDs for operation, relays, fault signal ● Configurable status indication via display background lighting
Measured value memory	Internal memory and SD card	Internal memory and SD card
Interfaces	Bluetooth LE	Bluetooth LE
Ambient temperature	-40 ... +60 °C (-40 ... +140 °F)	-40 ... +60 °C (-40 ... +140 °F)

3 Instrument selection

All controllers of the 100, 300 and 800 instrument series power the connected sensors, process the measured values and display these on the integrated display and adjustment unit. Up to two 4 ... 20 mA or 4 ... 20 mA/HART sensors can be connected depending on the instrument version.

The instruments enable simple implementation of pump controls, flow measurements on open channels and weirs, totalizers, difference, sum and average value calculations. Limit values can be reliably monitored and relays can be switched, e.g. for an overflow protection according to WHG.

All instruments have a graphic display with background lighting. This serves at the same time as a status display visible from a great distance. The background lighting changes in the delivery status according to NAMUR NE 107 (e. g. red for fault, orange for function check). Alternatively, the status display can also be configured based on the relay or the measured value. When the measured value is used, for example, up to five operating states can be signalled depending on the level.

The three instrument series 100, 300 and 800 differ mainly in the protection rating and the assembly possibilities and thus also in the housing.

VEGAMET series 100

The compact series is ideal for mounting on rails, e.g. in switch cabinets. A graphic display for on-site data visualisation and checking as well as a turn/press button for simple on-site adjustment are integrated.

VEGAMET series 300

The built-in housing is ideal for mounting in the panel or switch cabinet door. A large graphic display for on-site data visualisation and checking as well as a turn/push button for simple on-site adjustment are integrated.

VEGAMET series 800

The housings are designed for wall/pipe assembly and harsh field conditions, e.g. outdoors. A large graphic display for on-site data visualisation and checking as well as push buttons for easy on-site adjustment are integrated.

The VEGAMET 861/862 has 4 ... 20 mA/HART sensor inputs. Digital inputs and a measured value memory/data logger are additionally available.

4 Selection criteria

The following charts provide an overview of the standard applications and functions of the controllers. They also give information about whether the respective function can be activated and adjusted via the integrated indicating and adjustment unit (OP) or via DTM/app. ¹⁾

VEGAMET 141, 142

Applications (adjustable with DTM/app)		VEGAMET		Adjustment	
		141	142	OP	DTM/App
Universal		•	•	•	•
Level - storage tank		•	•		•
Calculation	Difference		•		•
	Total		•		•
	Average value		•		•
Wells		•	•		•
Pumping station		•	•		•
Sewage screw lifting station		•	•		•
Screen control			•		•
Flow measurement - flume/weir		•	•		•
Pressurized vessel			•		•
Additional application examples		VEGAMET		Adjustment	
		141	142	OP	DTM/App
Level measurement		•	•		•
Gauge measurement		•	•		•
Process pressure measurement		•	•		•
Overflow basin			•		•
Density			•		•
Functions		VEGAMET		Adjustment	
		141	142	OP	DTM/App
Application wizard		•	•		•
Indication measured values		•	•	•	•
Automatic display change		•	•	•	•
Configurable status indication via background lighting of the display		•	•		•
Display multilingual		•	•	•	•
Sensor input - 4 ... 20 mA		•	•	•	•
Damping		•	•	•	•
Linearisation	Predefined curves	•	•	•	•
	Dimensions - ISO standard	•	•		•
	Flow formula	•	•		•
	Manufacturer definition	•	•		•
	Calculation wizard	•	•		•
	Locating chart	•	•		•
	Measure	•	•		•
	Import	•	•		•
Adjustment of the measuring point		•	•	•	•
Scaling		•	•	•	•
Totalizer 1/2		•	•	•	•
Totalizer 3/4/5/6			•		•

¹⁾ OP: Operating Panel (integrated display and adjustment unit)

Functions		VEGAMET		Adjustment	
		141	142	OP	DTM/App
Relay mode	Overfill protection	•	•	•	•
	Dry run protection	•	•	•	•
	Switching window ON	•	•		•
	Switching window OFF	•	•		•
	Flow volume pulse	•	•		•
	Sampling pulse	•	•		•
	Tendency increasing	•	•		•
	Tendency decreasing	•	•		•
	Pump control 1 (same running time)	•	•		•
	Pump control 2 (same running time)	•	•		•
	Pump control 3 (fixed order)	•	•		•
	Pump control 4 (fixed order)	•	•		•
Mode	Pump control - sequenced operation	•	•		•
	Pump control - alternating pump operation	•	•		•
Dry weather pump		•	•		•
Forced pump changeover		•	•		•
Relay switch on and off delay		•	•		•
Bandwidth for switching points		•	•		•
Fail safe relay		•	•	•	•
Current output	0/4 ... 20 mA, 20 ... 4 mA	•	•	•	•
	Flow volume pulse	•	•		•
	Sampling pulse	•	•		•
Diagnostics	Status	•	•	•	•
	Measured values	•	•	•	•
Simulation	Sensor value, %, lin% value, scaled values	•	•	•	•
	Current output	•	•		•
	Relay output	•	•		•
Protection of the parameterization		•	•	•	•
Bluetooth access code		•	•	•	•
Activate/deactivate Bluetooth communication		•	•	•	•

VEGAMET 341, 342

Applications (adjustable with DTM/app)		VEGAMET		Adjustment	
		341	342	OP	DTM/App
Universal		•	•	•	•
Level - storage tank		•	•		•
Calculation	Difference		•		•
	Total		•		•
	Average value		•		•
Wells		•	•		•
Pumping station		•	•		•
Sewage screw lifting station		•	•		•
Screen control			•		•
Flow measurement - flume/weir		•	•		•
Pressurized vessel			•		•

Additional application examples		VEGAMET		Adjustment	
		341	342	OP	DTM/App
Level measurement		•	•		•
Gauge measurement		•	•		•
Process pressure measurement		•	•		•
Overflow basin			•		•

Additional application examples		VEGAMET		Adjustment	
		341	342	OP	DTM/App
Density			•		•
Functions		VEGAMET		Adjustment	
		341	342	OP	DTM/App
Application wizard		•	•		•
Indication measured values		•	•	•	•
Automatic display change		•	•	•	•
Configurable status indication via background lighting of the display		•	•		•
Display multilingual		•	•	•	•
Sensor input - 4 ... 20 mA		•	•	•	•
Damping		•	•	•	•
Linearisation	Predefined curves	•	•	•	•
	Dimensions - ISO standard	•	•		•
	Flow formula	•	•		•
	Manufacturer definition	•	•		•
	Calculation wizard	•	•		•
	Locating chart	•	•		•
	Measure	•	•		•
Linearization curves - Import		•	•		•
Adjustment of the measuring point		•	•	•	•
Scaling		•	•	•	•
Totalizer 1/2		•	•		•
Totalizer 3/4/5/6			•		•
Relay mode	Overfill protection	•	•	•	•
	Dry run protection	•	•	•	•
	Switching window ON	•	•		•
	Switching window OFF	•	•		•
	Flow volume pulse	•	•		•
	Sampling pulse	•	•		•
	Tendency increasing	•	•		•
	Tendency decreasing	•	•		•
	Pump control 1 (same running time)	•	•		•
	Pump control 2 (same running time)	•	•		•
	Pump control 3 (fixed order)	•	•		•
Pump control 4 (fixed order)	•	•		•	
Mode	Pump control - sequenced operation	•	•		•
	Pump control - alternating pump operation	•	•		•
Dry weather pump		•	•		•
Forced pump changeover		•	•		•
Relay switch on and off delay		•	•		•
Bandwidth for switching points		•	•		•
Fail safe relay		•	•	•	•
Current output	0/4 ... 20 mA, 20 ... 4 mA	•	•	•	•
	Flow volume pulse	•	•		•
	Sampling pulse	•	•		•
Diagnostics	Status	•	•	•	•
	Measured values	•	•	•	•
Simulation	Sensor value, %, lin% value, scaled values	•	•	•	•
	Current output	•	•		•
	Relay output	•	•		•
Protection of the parameterization		•	•	•	•
Bluetooth access code		•	•	•	•

Functions	VEGAMET		Adjustment	
	341	342	OP	DTM/App
Activate/deactivate Bluetooth communication	•	•	•	

VEGAMET 841, 842, 861, 862

Applications (adjustable with DTM/app)	VEGAMET				Adjustment	
	841	842	861	862	OP	DTM/App
Universal	•	•	•	•	•	•
Level - storage tank	•	•	•	•		•
Calculation - difference		•		•		•
Flow measurement - flume/weir	•	•	•	•		•
Pumping station	•	•	•	•		•
Screen control		•		•		•
Sewage screw lifting station	•	•	•	•		•

Additional application examples	VEGAMET				Adjustment	
	841	842	861	862	OP	DTM/App
Level measurement	•	•	•	•		•
Gauge measurement	•	•	•	•		•
Process pressure measurement	•	•	•	•		•

Functions	VEGAMET				Adjustment	
	841	842	861	862	OP	DTM/App
Application wizard	•	•	•	•		•
Indication measured values	•	•	•	•	•	•
Automatic display change	•	•	•	•	•	•
Configurable status indication via background lighting of the display	•	•	•	•		•
Display multilingual	•	•	•	•	•	•
Sensor input	4 ... 20 mA	•	•	•	•	•
	HART			•	•	•
Damping	•	•	•	•	•	•
Linearisation	Predefined curves	•	•	•	•	•
	Dimensions - ISO standard	•	•	•	•	•
	Flow formula	•	•	•	•	•
	Manufacturer definition	•	•	•	•	•
	Calculation wizard	•	•	•	•	•
	Locating chart	•	•	•	•	•
Measure	•	•	•	•	•	
Import linearization curves	•	•	•	•		•
Adjustment of the measuring point	•	•	•	•	•	•
Scaling	•	•	•	•	•	•
Totalizer 1/2	•	•	•	•		•
Totalizer 3/4		•		•		•

Functions		VEGAMET				Adjustment	
		841	842	861	862	OP	DTM/App
Relay mode	Overfill protection	•	•	•	•	•	•
	Dry run protection	•	•	•	•	•	•
	Switching window ON	•	•	•	•		•
	Switching window OFF	•	•	•	•		•
	Flow volume pulse	•	•	•	•		•
	Sampling pulse	•	•	•	•		•
	Tendency increasing	•	•	•	•		•
	Tendency decreasing	•	•	•	•		•
	Pump control 1 (same running time)	•	•	•	•		•
	Pump control 2 (same running time)	•	•	•	•		•
	Pump control 3 (fixed order)	•	•	•	•		•
	Pump control 4 (fixed order)	•	•	•	•		•
Mode	Pump control - sequenced operation	•	•	•	•		•
	Pump control - alternating pump operation	•	•	•	•		•
Dry weather pump		•	•	•	•		•
Pump monitoring				•	•		•
Forced pump changeover		•	•	•	•		•
Relay - Switch on and off delay		•	•	•	•		•
Bandwidth for switching points		•	•	•	•		•
Fail safe relay		•	•	•	•	•	•
Current output	0/4 ... 20 mA, 20 ... 4 mA	•	•	•	•	•	•
	Flow volume pulse	•	•	•	•		•
	Sampling pulse	•	•	•	•		•
Diagnostics	Status	•	•	•	•	•	•
	Measured values	•	•	•	•	•	•
Simulation	Sensor value, %, lin% value, scaled values	•	•	•	•	•	•
	Current output	•	•	•	•		•
	Relay output	•	•	•	•		•
	Digital input			•	•		•
Date/Time				•	•	•	•
Internal device memory/SD card				•	•		•
Protection of the parameterization		•	•	•	•	•	•
Bluetooth access code		•	•	•	•	•	•

5 Mounting

5.1 VEGAMET 141, 142

Mounting options

VEGAMET is designed for carrier rail mounting (top hat rail 35 x 7.5 according to DIN EN 50022/60715). Due to its protection rating of IP20, the instrument is suitable for mounting in switching cabinets. It must be mounted vertically.

 A VEGAMET in Ex version is an auxiliary, intrinsically safe instrument and may not be installed in explosion-endangered areas.

5.2 VEGAMET 341, 342

Mounting options

The device is designed for recessed installation in a switching cabinet, housing front panel or switch cabinet door. The required cut-out is 92 x 92 mm (3.63 x 3.63 in) according to IEC 61554.

 A VEGAMET in Ex version is an auxiliary, intrinsically safe instrument and may not be installed in explosion-endangered areas.

Front panel mounting

Make sure that the cut-out required for mounting has a size of 92 x 92 mm (3.63 x 3.63 in).

Slide the device into the panel cut-out from the front.

Press the two tensioning elements into the provided gaps.

Screw in the two screws of the tensioning elements evenly with a screwdriver.

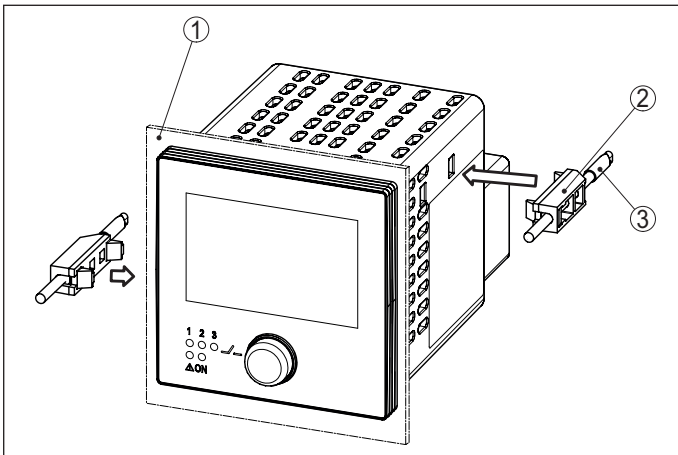

Fig. 2: Front panel mounting

- 1 Front panel, front plate or switching cabinet door
- 2 Clamping elements
- 3 Slotted screw

5.3 VEGAMET 841, 842, 861, 862

Mounting options

The field housing of the VEGAMET is equally suitable for outdoor or indoor installation due to its degree of protection IP66/IP67 and Type 4X. The standard version is designed for wall mounting. A mounting adapter for pipe mounting is available as an option.

Wall mounting

Fix the mounting plate to the wall using the screws and dowels supplied as shown in the figure below. Make sure that the arrows on the mounting plate point upwards.

Loosen the four screws in the housing cover and open it to the left. Fasten the device to the mounting plate using the screws (M5) supplied.

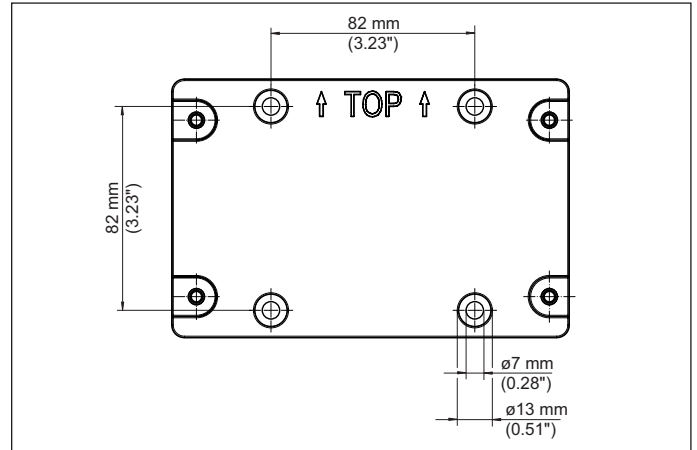

Fig. 3: Mounting plate for wall mounting (VEGAMET 841, 842)

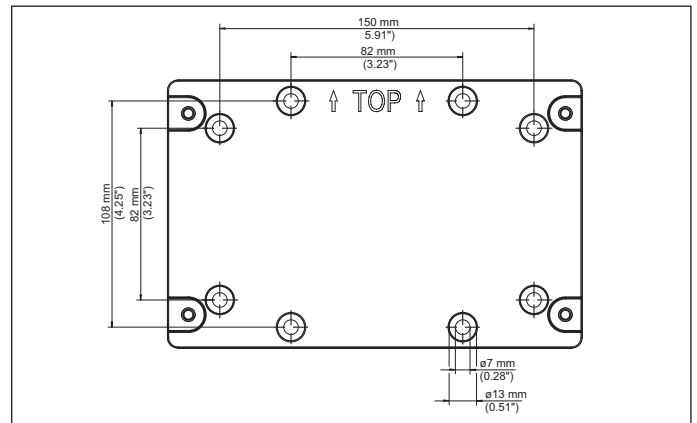

Fig. 4: Mounting plate for wall mounting (VEGAMET 861, 862)

Tube mounting

The optionally available mounting accessories are required for tube mounting. The kit consists of two pairs of mounting brackets and four mounting screws M6 x 100.

The mounting brackets are screwed to the mounting plate and the tube as shown in the following illustration.

Loosen the four screws in the housing cover and open it to the left. Fasten the device to the mounting plate using the screws (M5) supplied.

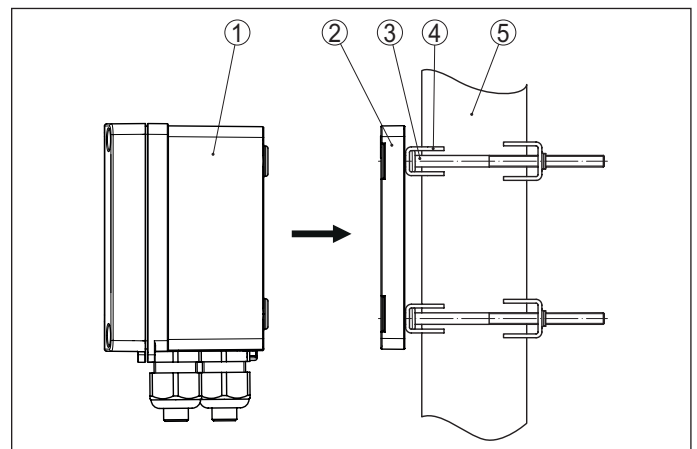

Fig. 5: Tube mounting

- 1 VEGAMET
- 2 Mounting plate
- 3 4 screws M6 x 100
- 4 Mounting brackets
- 5 Pipe for diameter 29 ... 60 mm (1.14" to 2.36")

Mounting sun shade

The optional sun protection can be used to protect against direct sunlight. The sunshade is simply mounted between the mounting plate and the controller, this is possible for both wall and pipe mounting.

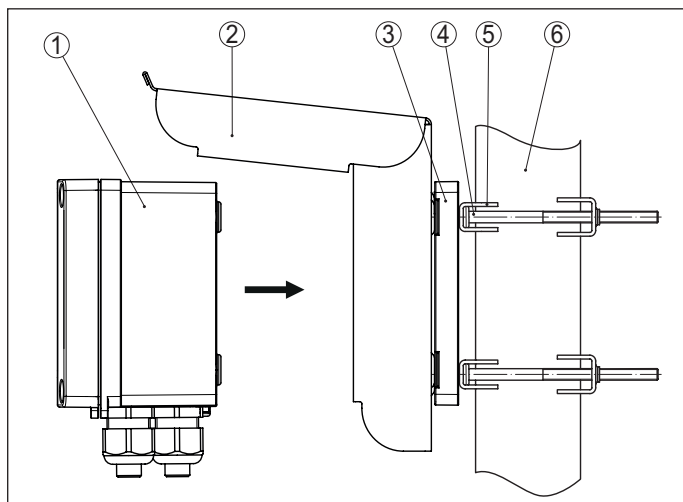

Fig. 6: Mounting sun protection with pipe mounting

- 1 VEGAMET
- 2 Sun shade
- 3 Mounting plate
- 4 4 screws M6 x 100
- 5 Mounting brackets
- 6 Pipe for diameter 29 ... 60 mm (1.14" to 2.36")

6 Electrical connection

6.1 Preparing the connection

Safety instructions

Always keep in mind the following safety instructions:

- The electrical connection must only be carried out by trained, qualified personnel authorised by the plant operator.
- If overvoltage surges are expected, overvoltage arresters should be installed.



Warning:

Only connect or disconnect in de-energized state.

6.2 Connection VEGAMET 141

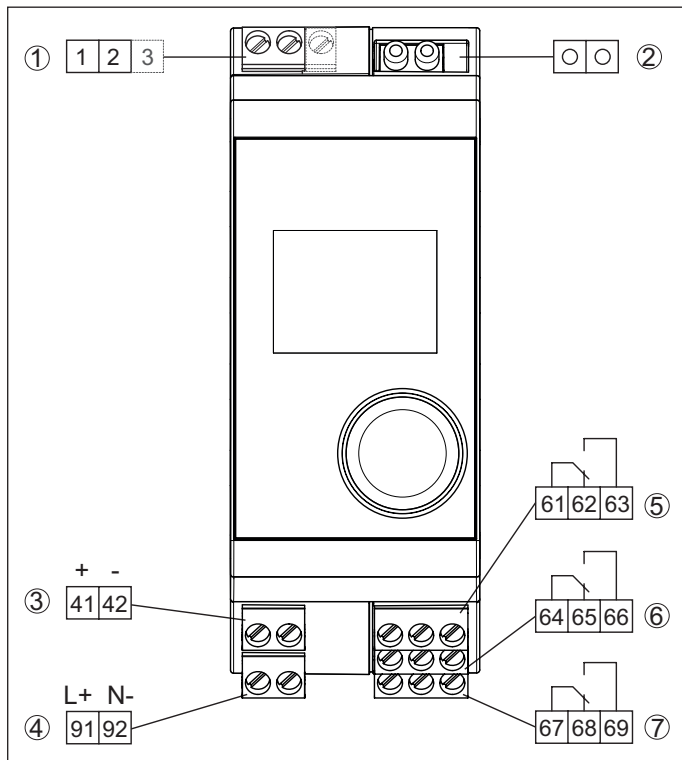

Fig. 7: Wiring plan VEGAMET 141

- 1 Sensor input (active/passive)²⁾
- 2 HART sockets for connection of a VEGACONNECT
- 3 4 ... 20 mA current output
- 4 Voltage supply of the controller
- 5 Relay output 1
- 6 Relay output 2
- 7 Relay output 3

²⁾ Passive input not available for Ex version
³⁾ Passive input 1 not available for Ex version

6.3 Connection VEGAMET 142

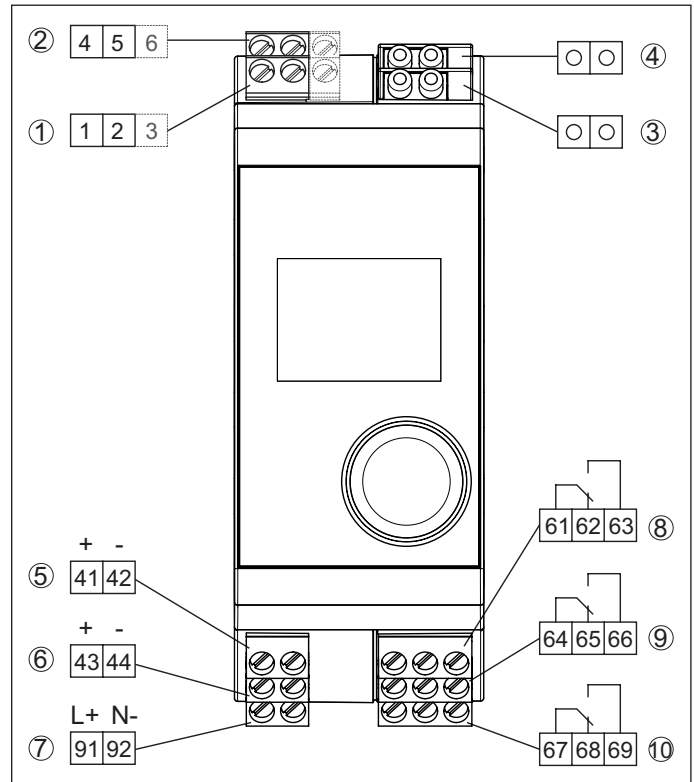

Fig. 8: Wiring plan VEGAMET 142

- 1 Sensor input 1 (active/passive)³⁾
- 2 Sensor input 2 (active/passive)⁴⁾
- 3 HART sockets input 1 for connection of a VEGACONNECT
- 4 HART sockets input 2 for connection of a VEGACONNECT
- 5 4 ... 20 mA current output 1
- 6 4 ... 20 mA current output 2
- 7 Voltage supply of the controller
- 8 Relay output 1
- 9 Relay output 2
- 10 Relay output 3

⁴⁾ Passive input 2 not available for Ex version

6.4 Connection VEGAMET 341

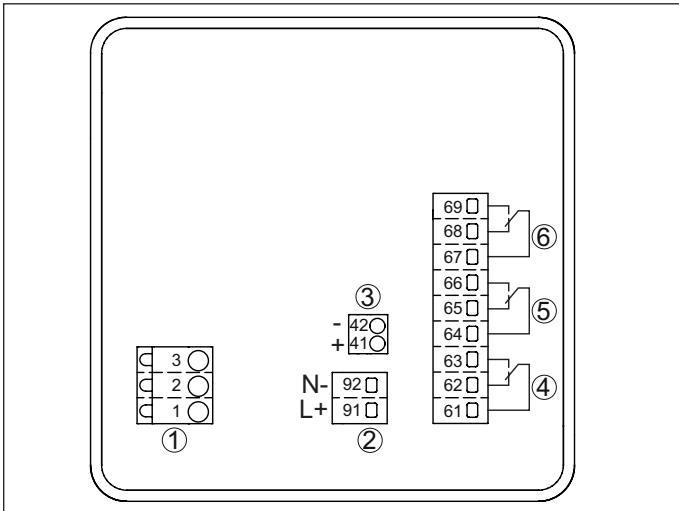

Fig. 9: Wiring plan VEGAMET 341

- 1 Sensor input (active/passive) and HART sockets for connecting a VEGACONNECT⁵⁾
- 2 Voltage supply of the controller
- 3 4 ... 20 mA current output
- 4 Relay output 1
- 5 Relay output 2
- 6 Relay output 3

6.5 Connection VEGAMET 342

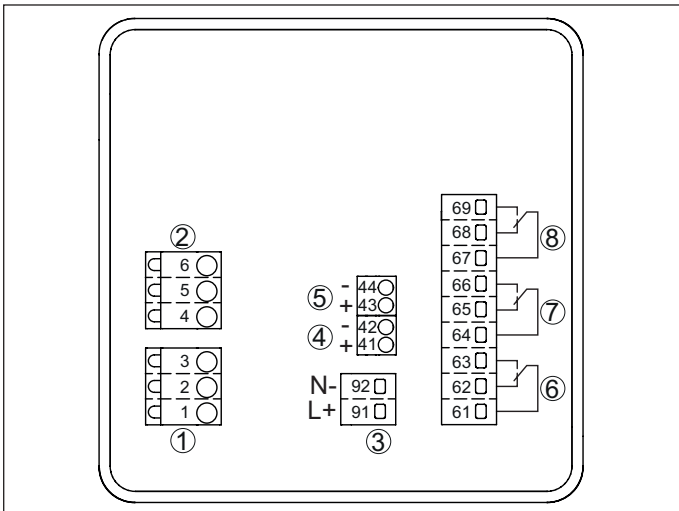

Fig. 10: Wiring plan VEGAMET 342

- 1 Sensor input 1 (active/passive)⁵⁾
- 2 Sensor input 2 (active/passive)⁷⁾
- 3 Voltage supply of the controller
- 4 4 ... 20 mA current output 1
- 5 4 ... 20 mA current output 2
- 6 Relay output 1
- 7 Relay output 2
- 8 Relay output 3

⁵⁾ Passive input not available for Ex version
⁶⁾ Passive input 1 not available for Ex version

6.6 Connection VEGAMET 841

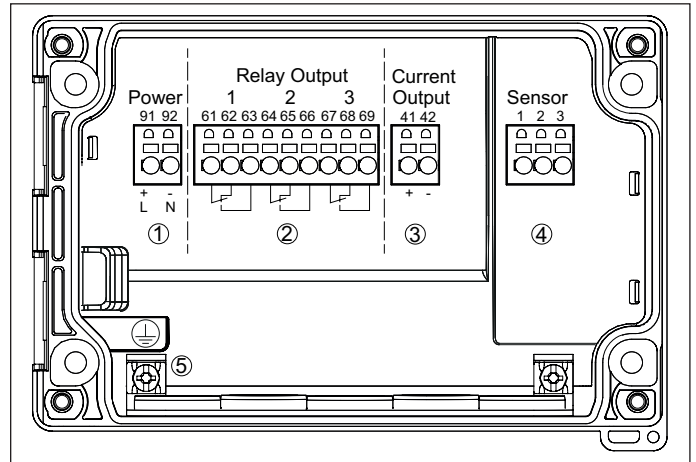

Fig. 11: Wiring plan VEGAMET

- 1 Voltage supply of the controller
- 2 Relay outputs 1 ... 3
- 3 Current output
- 4 Sensor input (active/passive)
- 5 Ground terminal for protective conductor

Details on the electrical connection can be found in the operating instructions of the device in the download area on our homepage.

6.7 Connection VEGAMET 842

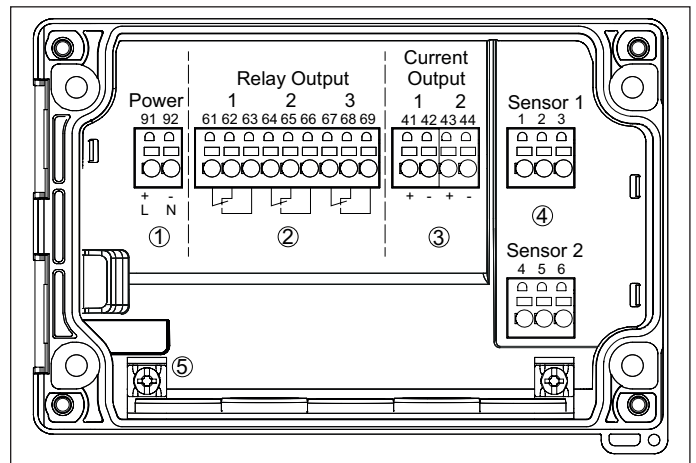

Fig. 12: Wiring plan VEGAMET

- 1 Voltage supply of the controller
- 2 Relay outputs 1 ... 3
- 3 Current outputs 1/2
- 4 Sensor inputs 1/2 (active/passive)
- 5 Ground terminal for protective conductor

Details on the electrical connection can be found in the operating instructions of the device in the download area on our homepage.

⁷⁾ Passive input 2 not available for Ex version

6.8 Connection VEGAMET 861

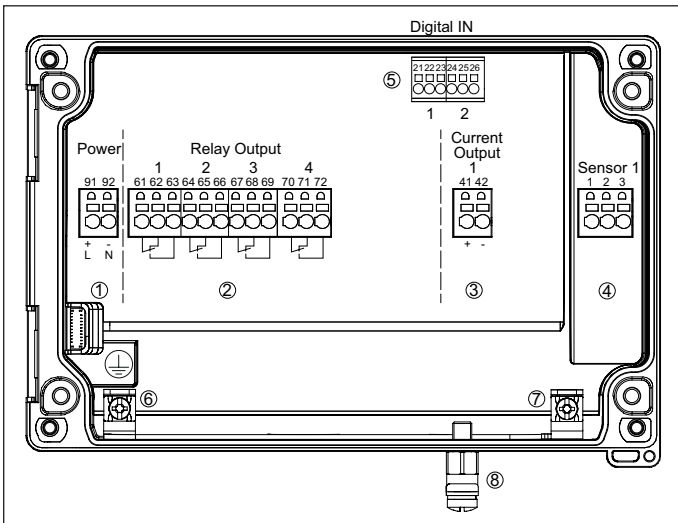

Fig. 13: Wiring plan VEGAMET

- 1 Voltage supply of the controller
- 2 Relay outputs 1 ... 4
- 3 Current output
- 4 Sensor input (active/passive)
- 5 Digital inputs 1/2
- 6 Ground terminal for protective conductor
- 7 Ground terminal for cable screening sensor cable
- 8 Ground terminal for potential equalization

6.9 Connection VEGAMET 862

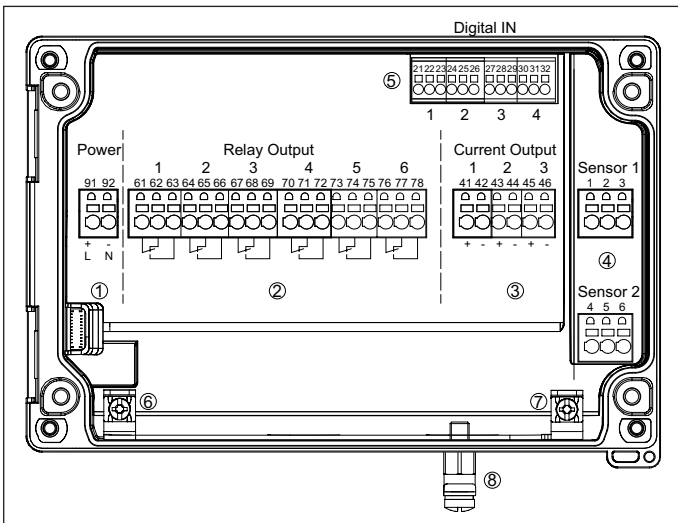

Fig. 14: Wiring plan VEGAMET

- 1 Voltage supply of the controller
- 2 Relay outputs 1 ... 6
- 3 Current outputs 1 ... 3
- 4 Sensor inputs 1/2 (active/passive)
- 5 Digital inputs 1 ... 4
- 6 Ground terminal for protective conductor
- 7 Ground terminal for cable screening
- 8 Ground terminal for potential equalization

7 Adjustment

7.1 Adjustment options and access protection

All controllers have an integrated display and adjustment unit. In addition, the instruments can be parameterised via Bluetooth and corresponding adjustment tools.

Adjustment via the display and adjustment unit

The adjustment is carried out menu-driven via four front keys or a turn/push button as well as a clearly arranged, graphic-capable LC-display with background lighting.

Wireless adjustment via Bluetooth

The integrated Bluetooth module enables wireless connection to smartphones/tablets (iOS/Android) or Windows PCs.

Operation is via a free app from the "Apple App Store", the "Google Play Store" or the "Baidu Store". Alternatively, adjustment can also be carried out via PACTware/DTM and a Windows PC.



Fig. 15: Wireless connection to smartphone/table/notebook



Information:

Certain setting options are not possible or only possible to a limited extent on site with the integrated display and adjustment unit, for example the settings for flow measurement or pump control. For these applications, the use of PACTware/DTM or the VEGA Tools app is recommended. An overview of the available applications and functions as well as their adjustment options can be found in chapter "Selection criteria".

Access protection

Devices with a Bluetooth radio interface are protected against unwanted access from outside. This means that only authorized persons can receive measured and status values and change device settings via this interface.

Protection of the parameterization

The settings (parameters) of the device can be protected against unwanted changes. The parameter protection is deactivated on delivery, all settings can be made.

8 Dimensions

VEGAMET 141, 142

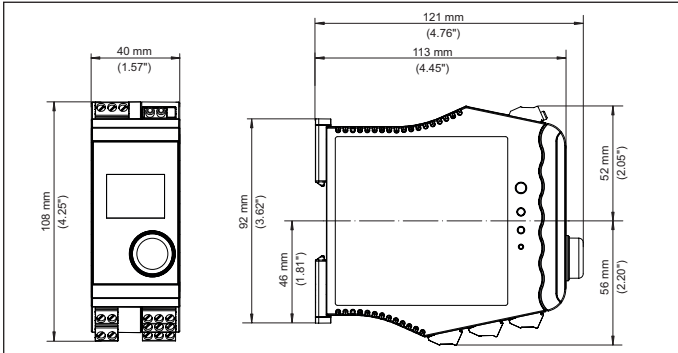

Fig. 16: Dimensions VEGAMET 141

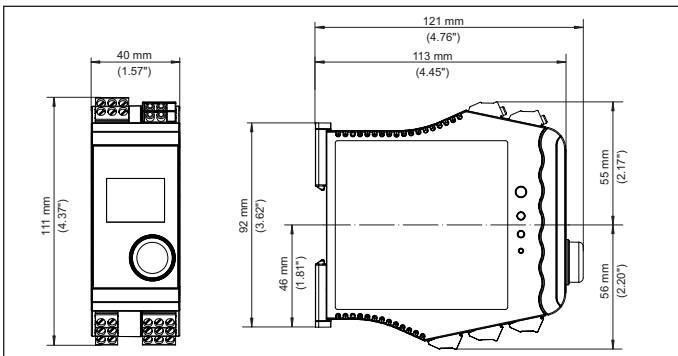

Fig. 17: Dimensions VEGAMET 142

VEGAMET 341, 342

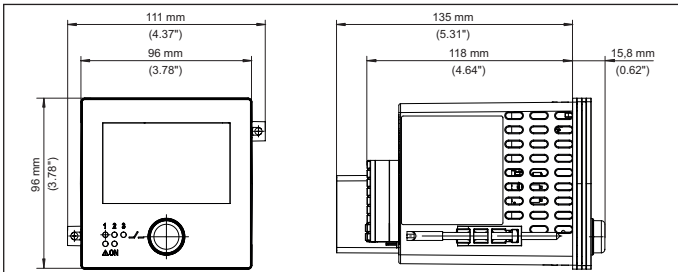

Fig. 18: Dimensions VEGAMET 341

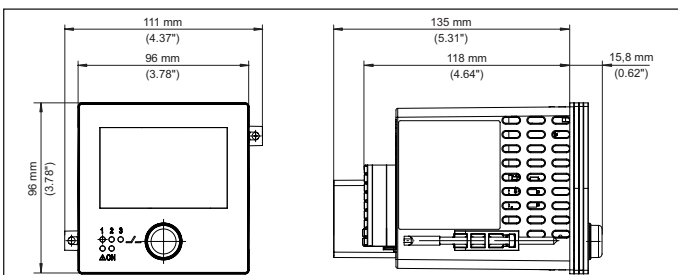

Fig. 19: Dimensions VEGAMET 342

VEGAMET 841, 842

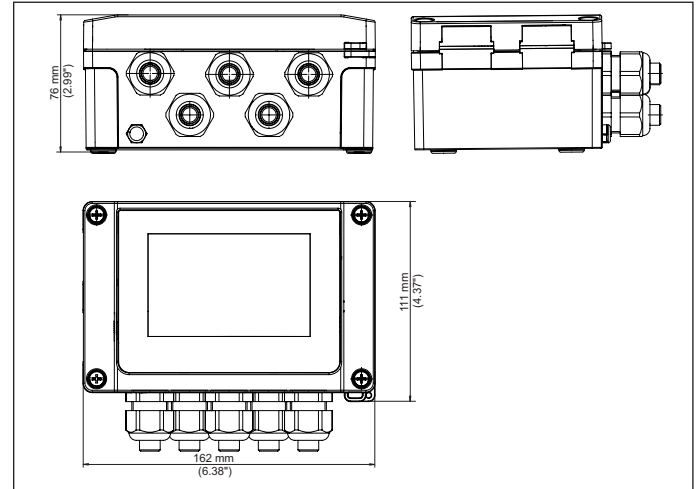

Fig. 20: Dimensions VEGAMET 841, 842

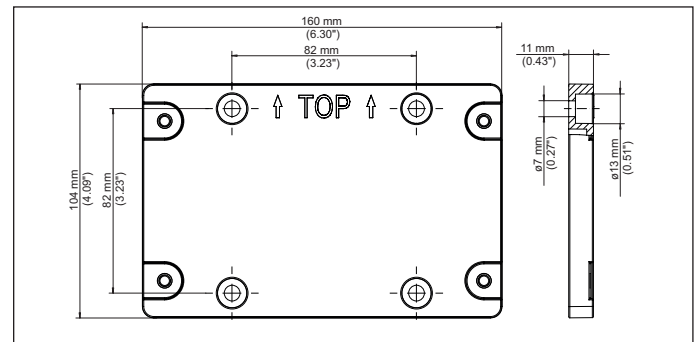

Fig. 21: Dimensions Wall mounting VEGAMET 841, 842

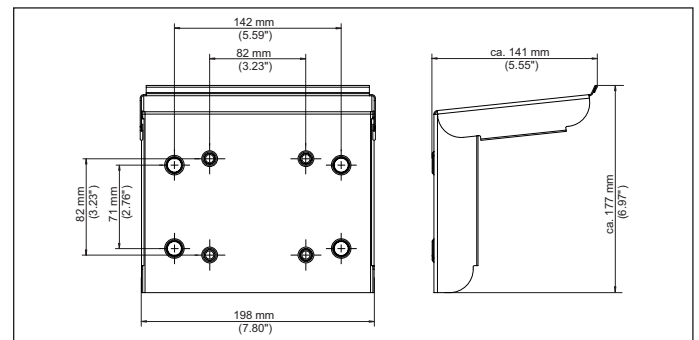

Fig. 22: Dimensions Sun shade VEGAMET 841, 842

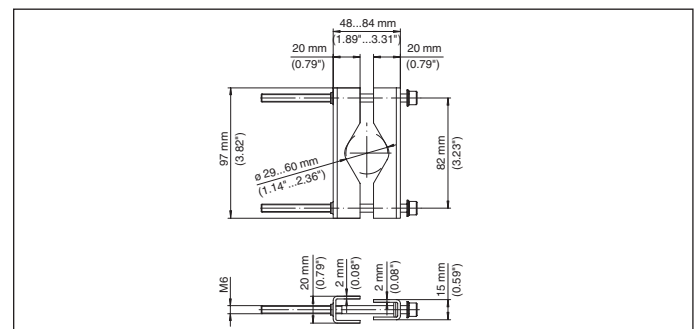

Fig. 23: Dimensions Brackets for tube mounting VEGAMET 841, 842

VEGAMET 861, 862

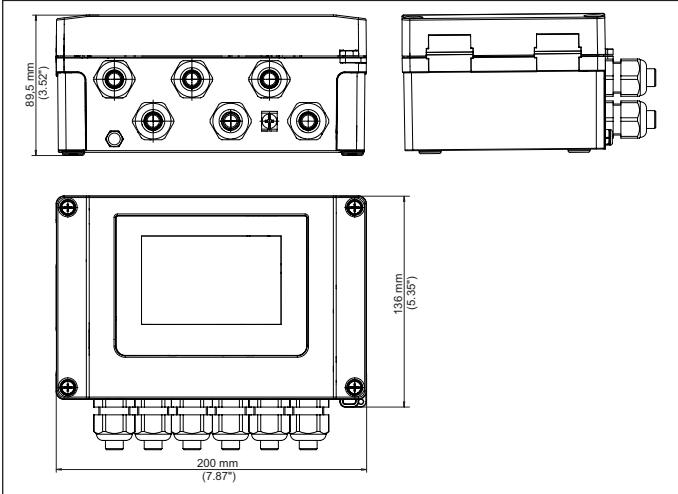

Fig. 24: Dimensions VEGAMET 861, 862

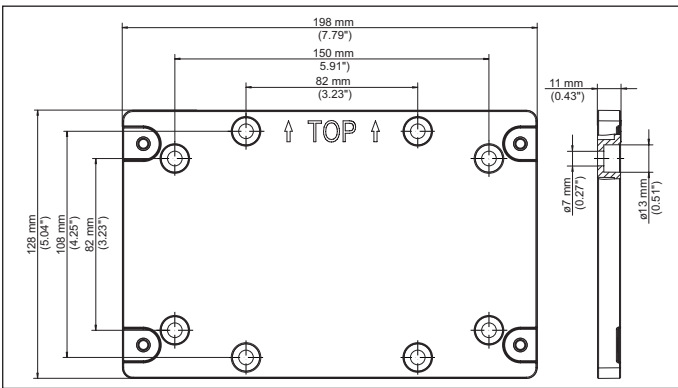

Fig. 25: Dimensions Wall mounting VEGAMET 861, 862

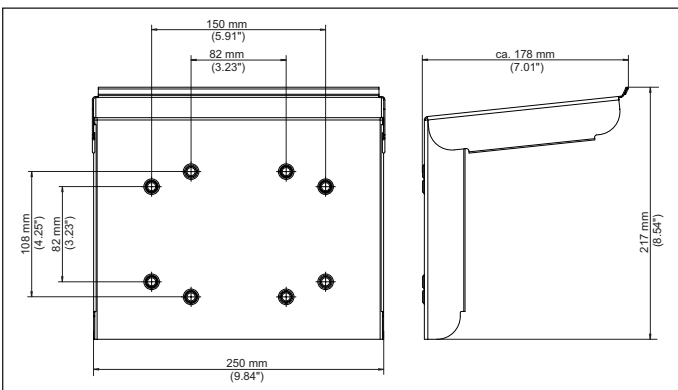

Fig. 26: Dimensions Sun shade VEGAMET 861, 862

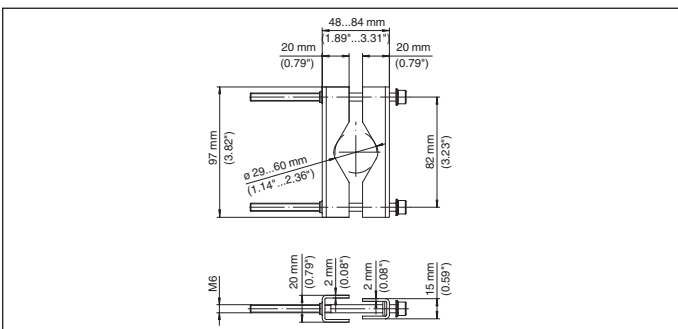

Fig. 27: Dimensions Brackets for tube mounting VEGAMET 861, 862



All statements concerning scope of delivery, application, practical use and operating conditions of the sensors and processing systems correspond to the information available at the time of printing.
Subject to change without prior notice

© VEGA Grieshaber KG, Schiltach/Germany 2021



**THORNE &
DERRICK**
INTERNATIONAL

Thorne & Derrick
+44 (0) 191 410 4292
www.heatingandprocess.com

VEGA